

QUICK COUPLINGS

WATER SERIE

tst[®]

SMART SOLUTIONS FOR INDUSTRIAL CONNECTIONS

TAMSAN BAĞLANTI ELEMANLARI A.Ş.

GEPOSB Gebze / Kocaeli TURKEY
Factory Tel : +90 262 751 20 44

www.tst-tamsan.com

© Release Date: 02/2022 TST-TAMSAN

tst QUICK COUPLINGS / WATER SERIE

QUICK COUPLINGS

WATER SERIE



tst[®]

SMART SOLUTIONS FOR INDUSTRIAL CONNECTIONS

www.tst-tamsan.com



SMART SOLUTIONS FOR INDUSTRIAL CONNECTIONS

QUICK COUPLINGS

WATER SERIE

Registered to
IATF 16949

Registered to
ISO 9001

SMART SOLUTIONS

EN

TST Group Worldwide

Founded over 30 years ago, we now have a Production Facility that occupies over 11.700 sq m². Our broad range of products are designed, manufactured and constantly developed under the same roof, to meet the needs of our Worldwide Customers.

tst is fully integrated manufacturer of quick connect/disconnect couplings, for hydraulic, pneumatic, vacuum, gas, chemical fluid and water applications; in addition to multi couplers, fittings, hoses and accessories.

The latest technologies are utilized to Manufacture and Assembly our wide range of products to the required specifications to achieve Zero Defects and 100% Delivery Performance.

DE

TST Gruppe weltweit

Gegründet vor 30 Jahren verfügen wir mittlerweile über eine Produktionskapazität auf Basis modernster CNC Technik auf über 11.700 m² Fläche. Um die Ansprüche unserer weltweiten Kunden zu erfüllen, sind Entwicklung und Produktion am gleichen Standort eng miteinander verbunden.

tst ist ein Hersteller von Schnellverschlusskupplungen für die Bereiche Hydraulik, Pneumatik, Vakuum, Gas, chemische Anwendungen, sowie Wasserapplikationen. Dies umfasst sowohl Einzelkupplungen als auch Multikupplungen, Verbindungselemente, Schläuche und Zubehör.

Um bei unserer breiten Angebotsvielfalt sowohl in der Herstellung als auch in der Montage absolute Liefertreue bei einer Fehlerquote von 0 ppm zu erreichen greifen wir auf modernste Fertigungsmethoden, langjährige Mitarbeitererfahrungen und einen sehr jungen Maschinenpark (vornehmlich CNC Technik) zurück.



FOR INDUSTRIAL CONNECTIONS

FR

TST, un groupe international

La Société TST fondée depuis plus de 30 ans dispose d'un site de fabrication de plus de 11.700m² où l'ensemble des produits sont dessinés, fabriqués et où le service développement est sans cesse à l'écoute des clients.

tst dispose de l'ensemble des produits coupleurs rapide comme le coupleur air, eau industrie ainsi que les coupleurs spéciaux "plasturgie" ou "hydraulique" ainsi que les gammes multi-connecteurs, manifolds, tubes, colliers et accessoires.

Toutes les technologies à la pointe de la technique sont utilisées sur toutes les phases de conception et production afin de vous assurer 100% de satisfaction quant à la performance des produits.

NL

TST, een wereldwijde organisatie

30 jaar geleden werd TST opgericht, inmiddels beschikken we over een productiefaciliteit die meer dan 11.700m² in beslag neemt.

Om te kunnen voldoen aan de behoeftes van onze wereldwijde klanten wordt ons brede assortiment aan producten onder één dak ontworpen, geproduceerd en doorontwikkeld.

tst is producent van snelkoppelingen, voor hydraulische, pneumatische, gas, vacuüm, chemische vloeistoffen en water-gerelateerde toepassingen. Daarnaast produceert TST ook enkele koppelingen, meervoudige koppelingen, verbindingselementen, fittingen, slangen en overige toebehoren.

tst

tamsan



Index

Table of Contents

TST WATER

PAGES

▪ Symbol of Types	05 - 06
▪ General Technical Information	07 - 08
▪ Certifications	09
▪ Flow Direction Index	10
▪ Icon Index	11 - 12
▪ SERIE 010	13 - 15
▪ SERIE 6 - 9 - 16	16 - 26
▪ SERIE 047	27
▪ SERIE 059 - 060 - 090 - 190	28 - 40
▪ SERIE 070	41 - 45
▪ SERIE 071	46 - 47
▪ SERIE 072	48 - 49
▪ SERIE 091	50
▪ SERIE 093	51 - 52
▪ SERIE 098	53 - 54
▪ SERIE 099	55 - 56
▪ SERIE 100	57 - 65
▪ SERIE 101	66 - 74
▪ SERIE 101.37	75 - 76
▪ SERIE 102	77 - 87
▪ SERIE 103	88 - 90
▪ SERIE 104	91 - 94
▪ SERIE 105	95 - 96
▪ SERIE 106	97 - 98
▪ SERIE 110	99 - 100
▪ SERIE 112	101 - 102
▪ SERIE 116	103 - 104
▪ SERIE 117K - 117KA - 117AK	105 - 109
▪ SERIE 118.09	110 - 111
▪ SERIE 120	112 - 113
▪ SERIE 121	114 - 115
▪ SERIE 124	116 - 121
▪ SERIE 126	122 - 123

Index

Table of Contents

TST WATER

PAGES

▪ SERIE 127	124
▪ SERIE 128	125 - 126
▪ SERIE 152mono	128
▪ SERIE 160	129 - 130
▪ SERIE 161	131 - 132
▪ SERIE 165	133 - 135
▪ SERIE 271	136 - 137
▪ SERIE 300	138
▪ SERIE 009M	139 - 147
▪ SERIE 090M	148 - 156
▪ SERIE 106M	157 - 162
▪ SERIE 109M	163 - 171
▪ SERIE 112M	172 - 178
▪ SERIE 116M	179 - 182
▪ SERIE 104.06 / 104.08 M	183 - 184
▪ SERIE 108M	185 - 188
▪ SERIE 108M - HF	189 - 192
▪ SERIE 108ME	193
▪ SERIE 115.03M	194 - 197
▪ SERIE 115.05M	198 - 203
▪ SERIE 115mono	204
▪ SERIE 150.09M	205-210
▪ SERIE 150.12M	211-213
▪ SERIE 152.10M	214 - 222
▪ SERIE 152.12M	223 - 225
▪ SERIE 155.09M	226 - 232
▪ SERIE 208M	233 - 236
▪ SERIE 208M - HF	237 - 241
▪ SERIE SAGK	242
▪ MOULD ACCESSORIES	243 - 252
▪ HOSES	253 - 258
▪ HTA 10-13	259 - 260

Symbol of Types

Symbol Index

	EN	DE
B TYPE	<p>B Type Double Shut Off Series Couplings</p> <p>Both plug and coupling include the valve therefore self sealing is obtained regardless of the direction of flow.</p> <p>During disconnection, the flow will be blocked by the valves.</p>	<p>B Typ doppelseitig absperrende Kupplungsreihe</p> <p>Sowohl der Nippel wie die Kupplung sind mit einem Ventil versehen, so dass die Abdichtung unabhängig von der Durchflussrichtung sichergestellt werden kann.</p> <p>Nach dem Entkuppeln wird der Durchfluss durch das Ventil gesperrt.</p>
D TYPE	<p>D Type Double Shut off Couplings</p> <p>Both plug and valve include the valve therefore self sealing is obtained regardless of the direction of flow.</p> <p>During disconnection, the plug must be pushed into the coupling which provides a safety feature preventing accidents in medical applications.</p>	<p>D Typ doppelseitig absperrende Kupplung</p> <p>Sowohl der Nippel als auch das Ventil umfassen das Ventil, so dass unabhängig von der Strömungsrichtung eine Selbstabdichtung erzielt wird.</p> <p>Während des Trennens muss der Nippel in die Kupplung geschoben werden, was eine Sicherheitsfunktion bietet und die Unfälle in medizinischen Anwendungen verhindert.</p>
E TYPE	<p>E Type Single Shut Off Couplings</p> <p>Only the coupling includes valve therefore used in systems where the flow direction is from coupling to plug.</p> <p>During disconnection, the plug must be pushed into the coupling which provides a safety feature.</p>	<p>E Typ einseitig absperrende Kupplung</p> <p>Nur die Kupplung enthält ein Ventil, das daher in Systemen verwendet wird, bei denen die Durchflussrichtung von Kupplung zu Nippel verläuft.</p> <p>Beim Entkuppeln muss der Stecker in die Kupplung gedrückt werden, was eine Sicherheitsfunktion bietet.</p>
F TYPE	<p>F Type Thru-flow Couplings</p> <p>Coupling and plug do not include valve therefore no sealing is obtained.</p> <p>This type is generally used where sealing is not important.</p>	<p>F Typ Kupplung mit vollem Durchgang</p> <p>Kupplung und Nippel sind ventillos, daher wird keine Dichtung erreicht.</p> <p>Dieser Typ wird im Allgemeinen verwendet, wenn nur die Verbindung, jedoch nicht die Abdichtung im Vordergrund steht.</p>
K TYPE	<p>K Type Coded Couplings</p> <p>Coupling and plug have geometrical connection designs which only enables same geometrical shapes connect each other.</p> <p>This type prevents mismatches. Self sealing is optional.</p> <p>Please contact us to clarify which sealing option you prefer.</p>	<p>K Typ Kodierte Kupplung</p> <p>Kupplung und Nippel haben geometrische Verbindungsdesigns, die nur die Verbindung derselben geometrischen Formen ermöglichen.</p> <p>Dieser Typ verhindert Fehlverbindungen. Selbstdichtende Versionen sind optional erhältlich. Kontaktieren Sie uns, um zu klären, welche geometrische Form Sie bevorzugen.</p>
L TYPE	<p>L Type Coded Couplings</p> <p>Both coupling and plug include the valve and they close simultaneously while disconnection.</p> <p>The unique valf designs both sides prevent leakage during disconnection and obtain dry break.</p>	<p>L Typ kodierte Kupplung</p> <p>Kupplung und Nippel haben beide flachdichtende Ventil und schliessen gleichzeitig ab beim Entkuppeln.</p> <p>Entkuppeln ist leakagefrei.</p>
S TYPE	<p>S Type Coded Couplings</p> <p>Only the coupling includes valve therefore used in systems where the flow direction is from coupling to plug. Generally used in push-button couplings where a secure disconnection is required.</p> <p>Disconnection of the plug is possible only after two consecutive pushes; one for releasing the residual pressure and the second one to eject the plug.</p>	<p>S Typ kodierte Kupplung</p> <p>Nur die Kupplung enthält ein Ventil, daher die Verwendung, bei denen die Durchflussrichtung von Kupplung zu Stecker verläuft. Wird im Allgemeinen in Druckknopfkupplungen verwendet, bei denen eine sichere Trennung erforderlich ist.</p> <p>Das Lösen des Steckers ist nur nach zwei aufeinanderfolgenden Drücken (zwei Stufen) möglich. Eine zum Ablassen des Restdrucks und die zweite zum Auswerfen des Stopfens.</p>

Symbol of Types

Symbol Index

	FR	NL
B TYPE	<p>Type B série double obturation</p> <p>Le coupleur et l'embout disposent tous les deux de clapet. Par conséquent, l'étanchéité est obtenue quel que soit le sens du débit.</p> <p>Lors de la déconnexion, le débit sera bloqué par les clapets.</p>	<p>Snelkoppeling met dubbele klep, type B</p> <p>Zowel de insteeknippel als de snelkoppeling hebben een klep, waardoor de snelkoppeling zelfsluitend is ongeacht de stroomrichting.</p> <p>Bij het ontkoppelen blokkeren de kleppen de doorstroom.</p>
D TYPE	<p>Type D série double obturation à sécurité de désaccouplement.</p> <p>Le coupleur et l'embout disposent tous les deux de clapet. Par conséquent, l'étanchéité est obtenue quel que soit le sens du débit. Lors de la déconnexion, le débit sera bloqué par les clapets.</p> <p>Il faut agir sur la bague et sur l'embout simultanément pour désaccoupler en sécurité, évite tout désaccouplement intempestif, très employé dans les application médical.</p>	<p>Snelkoppeling met dubbele klep, type D</p> <p>Zowel de insteeknippel als de snelkoppeling hebben een klep, waardoor de snelkoppeling zelfsluitend is ongeacht de stroomrichting.</p> <p>Bij het ontkoppelen moet de insteeknippel in de snelkoppeling worden gedrukt; dit is een veiligheidsvoorziening die bij medische toepassingen ongevallen kan voorkomen.</p>
E TYPE	<p>Type E série simple obturation à sécurité de désaccouplement.</p> <p>Le coupleur dispose d'un clapet, embout passage libre.</p> <p>Il faut agir sur la bague et sur l'embout simultanément pour désaccoupler en sécurité, évite tout désaccouplement intempestif, très employé dans les applications médicales.</p>	<p>Snelkoppeling met enkele klep, type E</p> <p>Alleen de snelkoppeling heeft een klep; daarom wordt deze snelkoppeling gebruikt in systemen waarin het medium van de snelkoppeling naar de insteeknippel stroomt.</p> <p>Bij het ontkoppelen moet de insteeknippel in de snelkoppeling worden gedrukt; dit is een veiligheidsvoorziening.</p>
F TYPE	<p>Type F série passage libre</p> <p>Le coupleur et l'embout ne disposent pas de clapet, donc aucune étanchéité n'est obtenue.</p> <p>Ce type est généralement utilisé lorsque l'étanchéité n'est pas importante.</p>	<p>Volle-doorlaatsnelkoppelingen, type F</p> <p>Snelkoppeling en insteeknippel hebben géén klep.</p> <p>Dit type wordt in het algemeen gebruikt als het afsluiten van de doorstroom niet belangrijk is.</p>
K TYPE	<p>Type K Accouplements codés à détrompeur</p> <p>Le coupleur et l'embout ont des conceptions de connexion géométriques qui ne permettent de connecter que les mêmes formes géométriques, et dispose d'un repère couleur.</p> <p>Ce type empêche les inversions de connexion. Veuillez nous contacter pour option de joint.</p>	<p>Gecodeerde snelkoppelingen, type K</p> <p>De snelkoppeling en de insteeknippel zijn voorzien van een geometrische vorm, waardoor alleen identieke geometrische vormen met elkaar gekoppeld kunnen worden.</p> <p>Hierdoor kunnen geen foute koppelingen worden gemaakt. Zelfafsluitende modellen zijn verkrijgbaar. Neem contact met ons op als u wilt weten welk type koppeling voor u de beste keuze is.</p>
L TYPE	<p>Type L série double obturation face plane, zéro gouttes.</p> <p>Le coupleur et l'embout disposent tous les deux de clapet. Par conséquent, l'étanchéité est obtenue quel que soit le sens du débit.</p> <p>Lors de la déconnexion, le débit sera bloqué par les clapets face plane assurant aucune fuite à l'accouplement ou désaccouplement.</p>	<p>Gecodeerde snelkoppelingen, type L</p> <p>Zowel de snelkoppeling als de insteeknippel hebben een klep, en beide kleppen sluiten bij het ontkoppelen gelijktijdig af.</p> <p>Het unieke ontwerp van de klep voorkomt lekkage bij het ontkoppelen, zodat 'droog' ontkoppeld kan worden.</p>
S TYPE	<p>Type S série simple obturation à sécurité anti coup de fouet ISO 4414EN983</p> <p>Seul le coupleur dispose de clapet, embout passage libre. Généralement utilisé dans les accouplements à bouton-poussoir où une déconnexion sécurisée est requise.</p> <p>La déconnexion de l'embout n'est possible qu'après deux poussées consécutives; un pour relâcher la pression résiduelle et un second pour éjecter l'embout.</p>	<p>Gecodeerde snelkoppelingen, type S</p> <p>Alleen de snelkoppeling heeft een klep; daarom wordt deze drukknopkoppelingen gebruikt in systemen waarin het medium van de drukknopkoppeling naar de insteeknippel stroomt. Dit type koppeling wordt in het algemeen gebruikt in toepassingen onder druk, waarbij veilig ontkoppelen vereist is.</p> <p>Het ontkoppelen van de insteeknippel is pas mogelijk nadat de drukknop twee keer achtereenvolgend ingedrukt is: één keer om de restdruk te laten vrijkomen en de tweede keer om de insteeknippel uit te werpen.</p>

General Technical Information

Material and Seals

Symbols - Korrosionstabelle

- ✓ Fully resistant / beständig
- ▣ Partly resistant / bedingt
- Non-resistant / nicht

	Material					Seal Dichtung		
	Steel zinc plated Stahl Verzinkt	Brass - Messing	AISI 316 Ti or similar Edelstahl AISI 316 Ti	Polyamide 11/12	Polyamid 11/12	Polyacetal - Poliasetal	NBR Nitrile	FPM Viton
Acetate (Ethyl Acetate & Amyl Acetate)	✓	✓	✓	✓	✓			x
Acetic acid 10%		—	✓	—	✓			x
Acetone	✓	✓	✓	✓	✓			x
Acetylene	✓	✓	✓	✓	✓		x x	x
Aero Engine Fuel BP, Esso Avgas100/130	✓	✓	✓	✓	▣		x x	
Aero Engine Oil BP : AIRO 1210, Esso:AVIATON-120 Shell:AIRO-120, DERD 2487 DERD 2497, DTD 585	✓	✓	✓	✓	▣		x x	
Skydrol	✓	—	✓	—	—			x
Oronite	✓	—	✓	—	—			x
Air, compressed	✓	✓	✓	✓	✓		x x	
Air, hot up to 120°C	✓	✓	✓	▣	—		x x	
Air, hot up to 200°C	✓	✓	✓	—	—			x
Alcohol	✓	✓	✓	✓	✓			x
Alum		—	✓	—	✓		x x x	
Alkalies	—	▣	✓	✓	▣		x x	
Ammonia, Liquid	▣	—	✓	✓	—			x
Ammonium Sulphate Solution	—	—	✓	✓	▣		x x x	
Amyl Alcohol	✓	✓	✓	✓	✓			x
Aniline	✓	—	✓	▣	—			x
Benzole	✓	✓	✓	✓	✓			x
Borax	✓	✓	✓	—	—			x x
Bultane	✓	✓	✓	✓	✓		x x	
Bultane	✓	✓	✓	—	—		x x	
Butyl Alcohol	—	✓	✓	✓	✓			x
Carbon Dixide	—	✓	✓	✓	✓		x x x	
Carbon Dioxide, dry		✓	✓	✓	—		x x x	
Carbon Dioxide liquid	—	✓	✓	✓	▣		x x x	
Carbon Bisulphide	✓	✓	✓	—	—			x
Chloride of Barium		✓	▣	✓	✓		x x x	
Chromic Acid	—	—	▣	▣	—			x
Citric Acid	—	▣	✓	—	▣			x x
Creosote	✓	✓	✓	—	—			x
Cresol	▣	✓	✓	—	—			x
Cresol, Cresylic Acid	✓	✓	✓	—	—			x
Cupric Chloride	✓	—	▣	—	—		x x x	
Cyclohexane	✓	✓	✓	▣	✓			x
Dimethylamine	✓	✓	✓	—	—			x
Emulsion. (Water/Oil)	▣	✓	✓	✓	✓		x x	
Ether	✓	✓	✓	✓	✓			x

Symbols - Korrosionstabelle

- ✓ Fully resistant / beständig
- ▣ Partly resistant / bedingt
- Non-resistant / nicht

	Material					Seal Dichtung		
	Steel zinc plated Stahl Verzinkt	Brass - Messing	AISI 316 Ti or similar Edelstahl AISI 316 Ti	Polyamide 11/12	Polyamid 11/12	Polyacetal - Poliasetal	NBR Nitrile	FPM Viton
Ethyl Alcohol	✓	✓	✓	✓	✓		x	x
Ethylene	✓	✓	✓	✓	✓			x
Formalin	✓	✓	✓	—	—		x x x	
Formic Acid	—	▣	✓	—	—			x
Frigen	✓	✓	✓	✓	✓		x x	
Gasoline, Refined	✓	✓	✓	—	—		x x	
Gas, Blast Furnace	▣	✓	✓	—	▣			x
Gas, Coal	▣	✓	✓	✓	✓			x
Gas, Coke Oven	▣	✓	✓	▣	▣		x	
Gas, Lighting	✓	✓	✓	✓	✓		x x	
Gas, Naphtalene content	✓	✓	✓	—	—		x x	
Gas, Natural	✓	✓	✓	✓	✓		x x	
Gas, Town	✓	✓	✓	✓	✓		x	
Gear Oil	✓	✓	✓	—	—		x x	
Glucose		✓	✓	✓	✓		x x x	
Glycerine	✓	✓	✓	✓	✓		x x x	
Glycol	✓	✓	✓	✓	✓		x x	
Helium	✓	✓	✓	✓	✓		x x x	
Hexane	✓	✓	✓	✓	▣		x x	
Hydrocarbons	✓	✓	✓	✓	✓		x x	
Hydrogen	✓	✓	✓	✓	▣		x x	
Hydrogen Gas	✓	✓	✓	—	—		x x	
Hydrogen Sulphide, Humid		▣	✓	✓	—			x
Hydrogen Sulphide, dry		✓	✓	✓	—			x
Hyrogen Peroxide 30%	—	—	✓	✓	—			x
Isoproyl Alcohol	✓	✓	✓	▣	✓		x x x	
Kerosene, JP 1	✓	✓	✓	✓	✓		x x	
Keton, Methytl Ethyl	✓	✓	✓	✓	✓			x
Latex, liquid up to 130°C	✓	✓	✓	▣	▣		x	
Lubricating Oil	✓	✓	✓	✓	✓		x x	
Lye, Caustic	—	✓	✓	✓	▣			x
Lye, Hyochorous Acid	—	✓	✓	—	▣			x
Lye, Pickling	—	MS60	✓	▣	▣			x
Magnesium Carbonate	✓	✓	✓	✓	✓		x x x	
Magnesium Hydroxide	✓	✓	✓	✓	✓		x x x	
Magnesium Sulphate, M,Sulfat		—	✓	✓	✓		x x x	
Mercury	✓	—	✓	✓	✓		x x x	
Methane	✓	✓	✓	✓	✓		x x	
Methanol	✓	✓	✓	✓	✓		x x	
Methyl Alcohol	✓	✓	✓	▣	✓		x x	
Methyl Ethyl Ketone	✓	✓	✓	✓	✓			x

General Technical Information

Material and Seals

	Material					Seal Dichtung		
	Steel zinc plated Stahl Verzinkt	Brass - Messing	AISI 316 Ti or similar Edelstahl AISI 316 Ti	Polyamide 11/12	Polyamid 11/12 Polyacetat - Poliasetat	NBR Nitrile	FPM Viton	EPDM
Symbols - Korrosionstabelle								
✓	Fully resistant / beständig							
■	Partly resistant / bedingt							
—	Non-resistant / nicht							
Methyl Benzene	✓	✓	✓	✓	✓	x		
Milk	✓	—	✓	✓	✓	x	x	
Napta	✓	✓	✓	✓	✓	x	x	
Naptalene	✓	✓	✓	✓	✓		x	
Naptenic. Acid	✓	✓	✓	✓	✓	x	x	
Nitrate of Ammonium	✓	✓	✓	✓	✓	x	x	x
Nitric Acid. up to 35°C	—	✓	✓	—	—		x	
Nitrogen	✓	✓	✓	✓	✓	x	x	x
Nitro-Solution (no synthetic resin thinners)	✓	✓	✓	—	✓			x
Oil, Coal Tr	✓	✓	✓	✓	■		x	
Oil, Crude	✓	✓	✓	✓	✓	x	x	
Oil, Diesel	✓	✓	✓	✓	✓		x	
Oil, Diesel up to 120°C	✓	✓	✓	■	—		x	
Oil, Fuel up to 100°C	✓	✓	✓	■	—	x	x	
Oil, up to 200°C/ 300°C ^{cup to (special type)}	✓	■	✓	—	—			FFKM
Oil, Fuel 5x5	✓	✓	✓	■	✓		x	
Oil, Hydraulic Chlorinated	■	■	✓	—	■		x	
Oil, Hydraulic up to 120°C	✓	✓	✓	■	■	x	x	
Oil, Linseed	✓	✓	✓	✓	✓	x	x	
Oil, Mineral	■	✓	✓	✓	✓	x	x	
Oil, Transformer	■	■	✓	✓	■		x	
Oleic Acid	✓	—	✓	✓	✓	x	x	
Oxalic Acid	■	■	✓	✓	✓		x	x
Oxygen. fat free	—	✓	✓	✓	■			x
Paraffin	✓	✓	✓	✓	✓		x	
Paraffin, (Wax)	✓	✓	✓	✓	✓		x	
Pentachlorphenole	✓	✓	✓	✓	✓		x	
Petrol Ether	✓	✓	✓	✓	✓	x		
Petrol	✓	✓	✓	✓	✓	x		
Phenol Solution	■	✓	✓	—	—			
Phosphoric Acid 10%	✓	✓	✓	—	—	x	x	
Potassium Cyanide	✓	—	✓	✓	■	x	x	
Potassium Dichromate	✓	—	✓	—	■	x	x	
Potassium Sulphate	✓	✓	✓	✓	✓	x	x	x
Potassium Hydroxide	✓	✓	✓	✓	■			x
Propane	✓	✓	✓	✓	✓	x	x	
Prussic Acid	✓	—	✓	✓	✓		x	
Salt Solution	—	■	■	✓	■		x	
Sea Water	—	■	✓	✓	✓	x	x	x

	Material					Seal Dichtung		
	Steel zinc plated Stahl Verzinkt	Brass - Messing	AISI 316 Ti or similar Edelstahl AISI 316 Ti	Polyamide 11/12	Polyamid 11/12 Polyacetat - Poliasetat	NBR Nitrile	FPM Viton	EPDM
Symbols - Korrosionstabelle								
✓	Fully resistant / beständig							
■	Partly resistant / bedingt							
—	Non-resistant / nicht							
Soap Solution	—	✓	✓	✓	✓	x	x	x
Soda Solution	—	■	✓	✓	■	x	x	x
Sodium Acetate	✓	✓	✓	✓	✓	x		x
Sodium Bicarbonate	✓	✓	■	✓	✓		x	x
Sodium Carbonate	✓	✓	✓	✓	✓	x	x	x
Sodium Chloride	✓	✓	✓	✓	✓	x	x	x
Sodium Cyanide	✓	✓	—	■	—			x
Sodium Sulphide	✓	■	✓	✓	✓		x	x
Steam, up to 150°C	■	■	✓	—	—			x
Steam, up to 250°C	■	■	✓	—	—			PTFE
Sulphide of barium	✓	■	✓	✓	✓	x	x	x
Sulphur Dioxide, Gas	✓	✓	✓	✓	✓			x
Sulphuret of Carbon	✓	✓	✓	—	✓			x
Syntetic Resin Thinners (no nitrosolution)	✓	✓	✓	■	■			x
Tar	✓	✓	✓	✓	✓	x	x	
Tetrachloride of Titanium	✓	✓	✓	✓	✓			x
Toluol, dry	■	✓	✓	✓	✓			x
Trichlorethylene	✓	■	✓	✓	—			x
Turbine Fuel, BP: ATK 2494, ESSO:MIL-F56/16, SHELL:ATF 650	✓	✓	✓	✓	■	x	x	
Turbine Oil, Esso:35	✓	✓	✓	✓	■	x	x	
Turb-oil 1 S (MILL 7808)	■	■	✓	✓	■	x	x	
Vacuum (Strengthened Valve Springs)	✓	✓	✓	✓	✓			
Vegetable Oil	✓	✓	✓	✓	✓	x	x	x
Water, Distilled	✓	✓	✓	✓	✓			x
Water, Deionized	✓	✓	✓	✓	✓	x	x	
Water, Demineralised	✓	✓	✓	✓	✓			x
Water, up to 80°C	■	✓	✓	■	■	x	x	x
Water, over 80°C	■	✓	✓	■	—			x
Water, Cooling	■	■	✓	✓	■	x	x	x
Xylene	✓	✓	✓	✓	✓			x

Connection Technology Worldwide

Precise Quality and Safety

EN

Our Company having been awarded ISO 9001 certification has now went through the final stages of IATF 16949 implementation process and is a IATF 16949 certified manufacturer since 2017.

DE

Unser Unternehmen ist ein ISO 9001 Zertifikat und ab April 2017 haben wir IATF 16949 Automotive Management System Zertifizierung erhalten. In diesem Bereich wollen wir unseren Anteil durch die Verbesserung unseres Geschäftsvolumens steigern testen.

FR

Notre société ayant reçu la certification ISO 9001 passe maintenant les étapes finales du processus de mise en œuvre IATF 16949 et ciblant ses clients en tant qu'établissement certifié IATF 16949 avant la fin de 2017.

NL

Ons bedrijf is al ISO 9001 - gecertificeerd en doorloopt nu de laatste fases van de implementatie van IATF 16949. Wij hopen voor eind 2017 onze klanten van dienst te kunnen zijn als IATF 16949-gecertificeerde onderneming.

**Registered to
IATF 16949**

**Registered to
ISO 9001**

Flow Direction and Sealing

Symbol Index

	EN	DE	FR	NL
	Thru-type coupling	Kupplung nicht absperrend	Coupleur passage libre	Snelkoppeling vrije doorlaat
	Self sealing coupling	Kupplung absperrend	Coupeur à clapet	Zelfsluitende snelkoppeling
	Thru-type coupling + Thru-type plug	Nicht absperrend	Coupleur et embout passage libre	Snelkoppeling vrije doorlaat + Insteeknippel vrije doorlaat
	Self Sealing coupling + thru-type plug	Einseitig absperrend	Coupleur à clapet et embout passage libre	Zelfsluitende snelkoppeling + Insteeknippel vrije doorlaat
	Self Sealing coupling + Self Sealing plug	Beidseitig absperrend	Coupleur et embout à clapet	Zelfsluitende snelkoppeling + Insteeknippel met terugslagklep

BF	Brass free
CN	Chemical nickel plated
DG	Degreased
ED	Safety lock
HF	High flow
HP	High pressure
KS	Retaining ring + O'ring
N	Nickel plated
N1	Sleeve nickel plated
OH	One hand connection
PD	Connection under pressure
PK	Dust guard
SF	Silicon free
TK	Dust cap
VA	Vacuum
YD	Raised push button
ZK	Fixing for protecting cap

COLOR CODE

S	BLACK	
B	BLUE	
KH	BROWN	
G	GREEN	
GR	GREY	
TU	ORANGE	
PI	PINK	
M	PURPLE	
R	RED	
Y	YELLOW	

Icon Index

Icons Related With Application Area



The pressure range vary for each product shown in this leaflet. Before ordering, please mention the application pressure to make sure the product meets the system requirements.



Temperature range of our products vary according to the sealing components chosen. Most common sealing types are listed below. For custom requirements, please contact us.



Is the actual diameter which fluid passes through. TST is capable of manufacturing products with nominal diameter of DN 2.5 mm's up to DN 75 mm's.

FLOW SYMBOLS

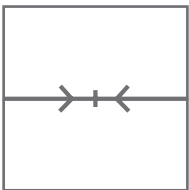

THROUGH FLOW
(Both Sides are Without Valve)

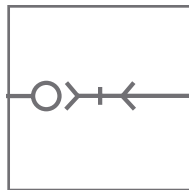

SINGLE SHUT OFF
(One Side is With Valve)

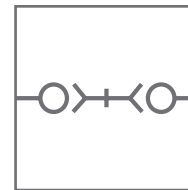

DOUBLE SHUT OFF
(Both Sides are With Valve)

MATERIAL ICONS



SEALING OPTIONS

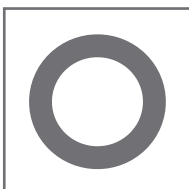

- FPM : -26°C to + 200°C (not recommended for water steam)
- NBR : -40°C to + 105°C
- EPDM : -50°C to + 135°C
- HT : -26°C to + 200°C (better durability for water steam up to 500 hours)
- FFKM : -15°C to + 325°C

Icon Index

Security Icons

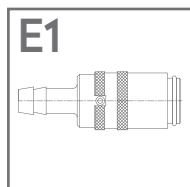
E1

The safety is provided by a pin on the sleeve to prevent disconnection by mistake.

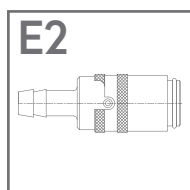
E2

This is an upgraded version of E1.

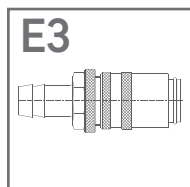
E3

Safety is provided by an additional nut screwed to the back of the sleeve to prevent accidental disconnection.

2 STAGE

Security is provided by pressing the button two times or by left-right sleeve twist. First press/twist releases the pressure inside the coupling and the second press/twist ejects the plug for disconnection.



This design is normally used in systems where confusion is certainly avoided by the geometrical design in the interior touch points of both plugs and couplings.

SWING

This is a built-in safety design type founded by Oetiker Inc. working in principle of ball valves in rotation with a locking sleeve. TST acquired Oetiker Inc.'s quick coupling division in 2012.

OTHER ICONS

FLOW

Flow rate

FF

Flat face

H4

Special design of the valve for high pressure

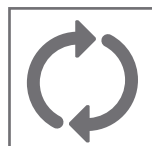

The number of input and outputs in multicoupling systems

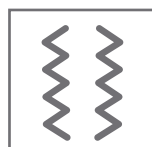

Thread size

NICKEL

Nickel Plated

PD

Connection under pressure

SWIVEL

360 °C rotation of the back part

L

Length

IN

Input thread size

OUT

Output thread size

SW

Hexagon size



Materials

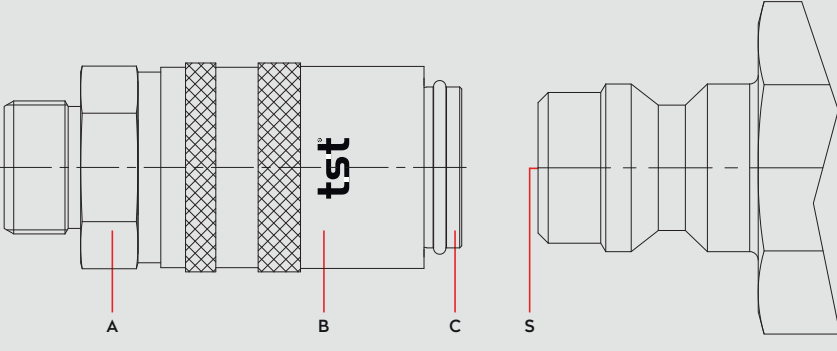

Material Code

- A = Brass
- B = Brass
- C = Brass
- S = Brass



0 - 25 bar



-26°C to + 200°C (FPM)

Shut Off Type

OV250 - 00865
OV250 - 00500 (valved)

Scandinavian Serie

DN 6 mm

Options

- E1
- E2
- NICKEL

Applications

Cooling System

Compatible with

DYROS 10
NITO

 MOULD COOLING COUPLINGS
 KÜHLUNGSELEMENTE FÜR WERKZEUGE

SERIE 010

QUICK COUPLINGS SCHNELLKUPPLUNGEN

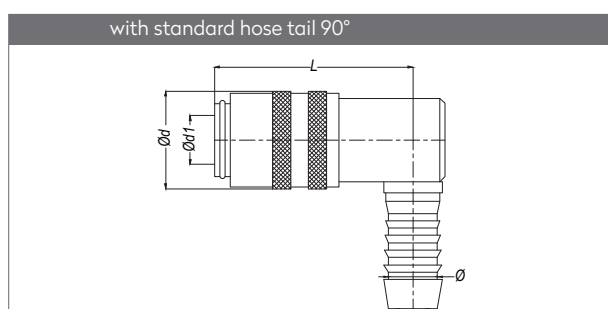
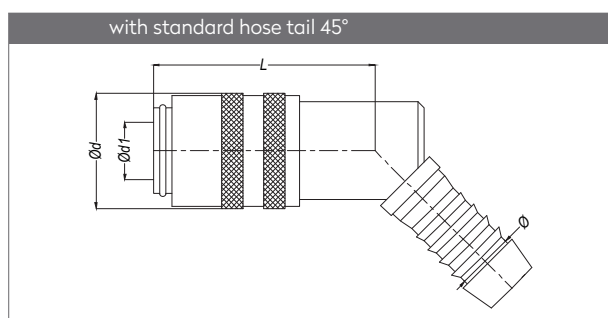
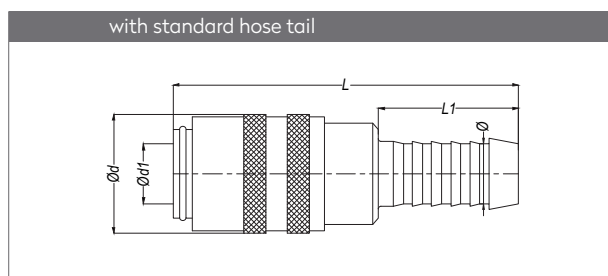
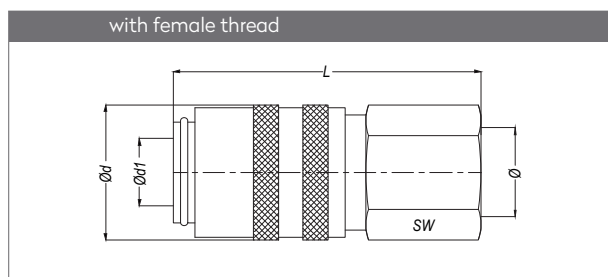
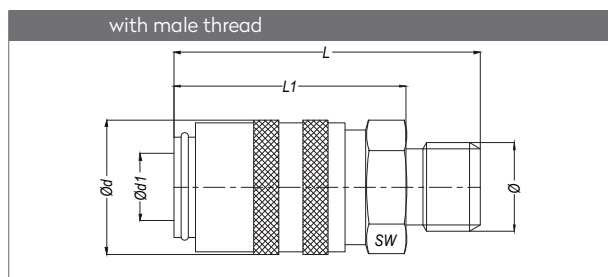

↻ / With Valve	← / Without Valve	Ø	Ød	Ød1	L	L1	SW
CSK 010-EG 10	SK 010-EG 10	BSP 1/8"	20	10	43.5	34.5	17
CSK 010-EG 13	SK 010-EG 13	BSP 1/4"	20	10	45.5	34.5	17
CSK 010-EG 17	SK 010-EG 17	BSP 3/8"	20	10	45.5	34.5	19

↻ / With Valve	← / Without Valve	Ø	Ød	Ød1	L	SW
CSK 010-DG 13	SK 010-DG 13	BSP 1/4"	20	10	45.5	17
CSK 010-DG 17	SK 010-DG 17	BSP 3/8"	20	10	45.5	19

↻ / With Valve	← / Without Valve	Ø	Ød	Ød1	L	L1
CSK 010-09	SK 010-09	9	20	10	58.1	23.5
CSK 010-10	SK 010-10	10	20	10	58.1	23.5
CSK 010-13	SK 010-13	13	20	10	58	23.5

↻ / With Valve	← / Without Valve	Ø	Ød	Ød1	L
CSK 010-10-45°	SK 010-10-45°	10	20	10	38.5
CSK 010-13-45°	SK 010-13-45°	13	20	10	38.5

↻ / With Valve	← / Without Valve	Ø	Ød	L
CSK 010-10-90°	SK 010-10-90°	10	20	40.5
CSK 010-13-90°	SK 010-13-90°	13	20	40.5

MOULD COOLING COUPLINGS
KÜHLUNGSELEMENTE FÜR WERKZEUGE

SERIE 010



QUICK COUPLINGS SCHNELLKUPPLUNGEN

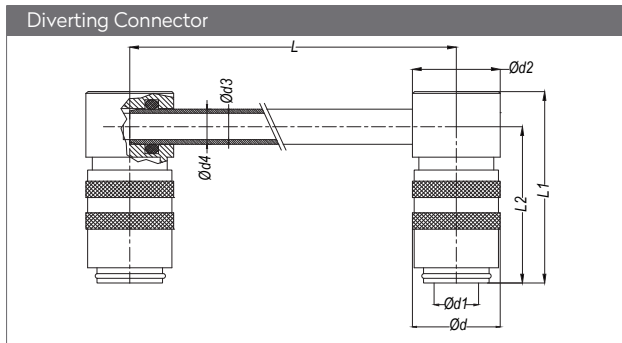

With Valve	Without Valve	Ød1	Ød4	Ød2	Ød3	Ød	L	L1	L2
CSK 010-KG 125	SK 010-KG 125	10	8	20	6	20	125	43.5	35.5
CSK 010-KG 250	SK 010-KG 250	10	8	20	6	20	250	43.5	35.5
CSK 010-KG 500	SK 010-KG 500	10	8	20	6	20	500	43.5	35.5

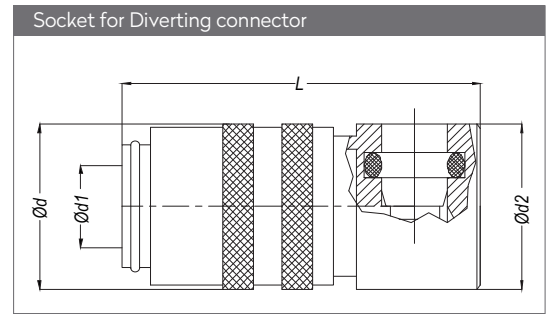

With Valve	Without Valve	Ød	L	Ød1	Ød2
CSK 010 KG 00	SK 010 KG 00	10	43.5	20	20

Part No. for the brass tube	Outer Ød	Thickness	Lenght
010 KPB 125	8	1	125
010 KPB 250	8	1	250
010 KPB 500	8	1	500

PLUGS STECKNIPPEL

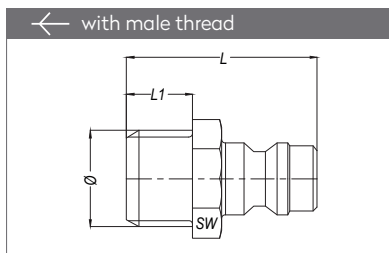

Part no.	Ø	SW	L	L1
010 EU 10	BSP 1/8"	11	24	7
010 EU 13	BSP 1/4"	14	26	9

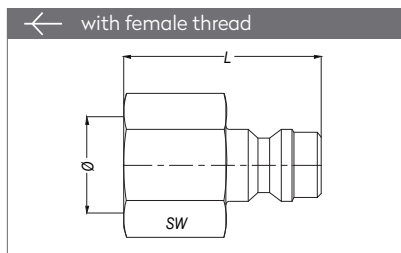

Part no.	Ø	SW	L
010 DU 10	BSP 1/8"	14	23
010 DU 13	BSP 1/4"	17	27

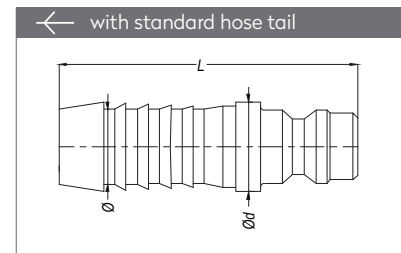

Part no.	Ø	Ød	L
010 HU 10	Ø10	12	40
010 HU 13	Ø13	15	40

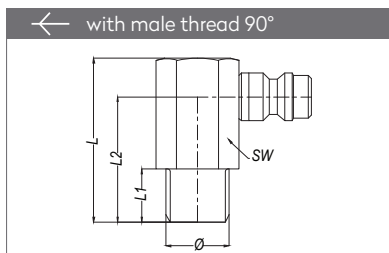

Part no.	Ø	SW	L	L1	L2
010 EU 10-90°	BSP 1/8"	11	25	7	18.5
010 EU 13-90°	BSP 1/4"	15	34	11	26

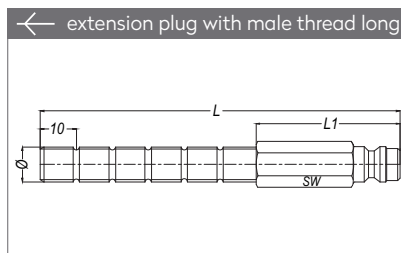

Part no.	Ø	SW	L	L1
010 BL 10x50	BSP 1/8"	11	50	40
010 BL 10x100	BSP 1/8"	11	100	40
010 BL 13x50	BSP 1/4"	14	50	40
010 BL 13x100	BSP 1/4"	14	100	40

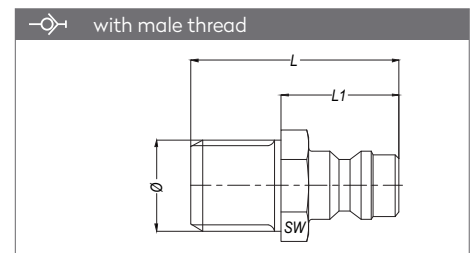

Part no.	Ø	SW	L	L1
010 EUB 13	BSP 1/4"	14	30	17
010 EUB 17	BSP 3/8"	17	30	17

VALVED PLUGS VERSCHLUßNIPPEL

SERIE 6-9-16





Materials

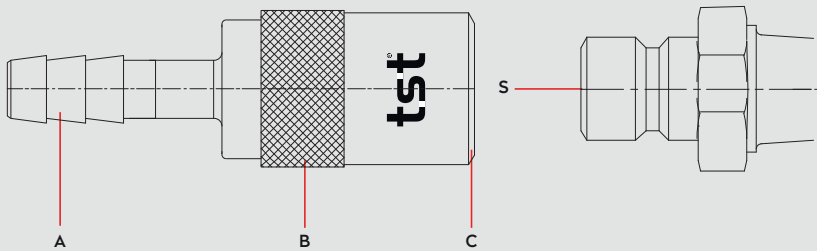

Material Code

- A = Brass
- B = Brass
- C = Brass
- S = Brass

0 - 15 bar

-26°C to + 200°C (FPM)

Shut Off Type

COUPLING

- TST 6 → 006 GC 00V
- TST 9 → 009 GC 00V
- TST 16 → 016 GC 00V

FLOW

- TST 6 → 35 lt/min →↔↔
- TST 9 → 60 lt/min →↔↔
- TST 16 → 85 lt/min →↔↔
- TST 6 → 15 lt/min ↔↔↔
- TST 9 → 30 lt/min ↔↔↔

DN

- TST 6 → 6 mm
- TST 9 → 9 mm
- TST 16 → 16 mm

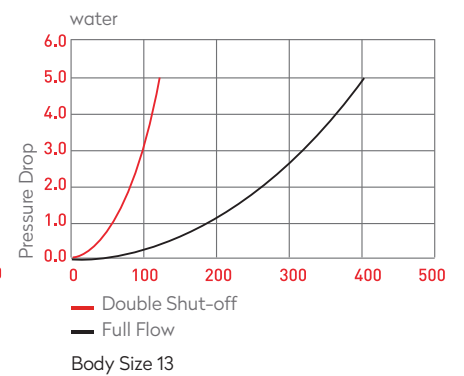
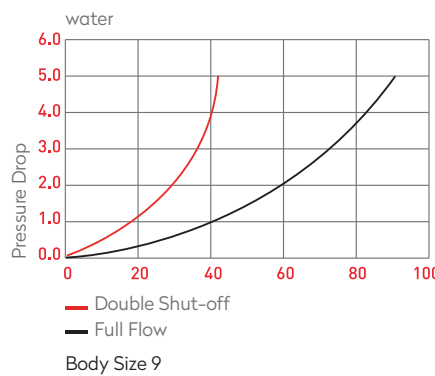
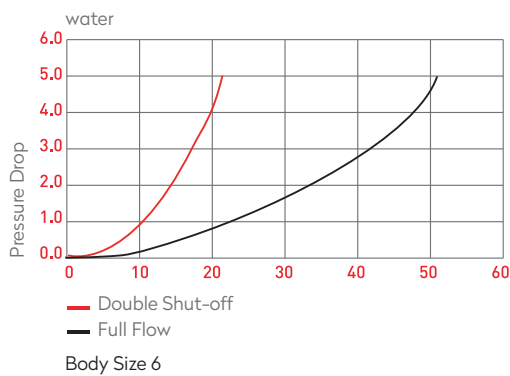

Options

Id. Ring E1 E2 NBR

NICKEL JR NPT

Applications

Cooling System

International Serie

Compatible with

DME
JIFFY TITE
RECTUS 86-87-88
LÜDECKE ESDMF 6, ESDF 9



 MOULD COOLING COUPLINGS
 KÜHLUNGSELEMENTE FÜR WERKZEUGE

SERIE 6-9-16

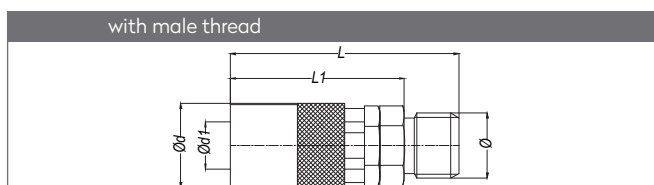
QUICK COUPLINGS SCHNELLKUPPLUNGEN

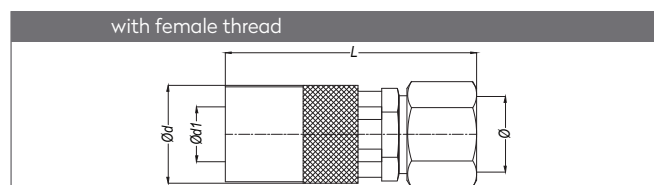

↻ / With Valve	← / Without Valve	Serie	Ø	Ød	Ød1	L	L1
HVK 6 EG 10	HK 6 EG 10	200	BSP 1/8"	17	9.5	44	35
HVK 6 EG 13	HK 6 EG 13	200	BSP 1/4"	17	9.5	46	35
HVK 6 EGM 14	HK 6 EGM 14	200	M14x1.5	17	9.5	46	35
HVK 6 EG 17	HK 6 EG 17	200	BSP 3/8"	17	9.5	46	35
HVK 9 EG 13	HK 9 EG 13	300	BSP 1/4"	23.3	13.5	56	45
HVK 9 EGM 16	HK 9 EGM 16	300	M16x1.5	23.3	13.5	56	45
HVK 9 EG 17	HK 9 EG 17	300	BSP 3/8"	23.3	13.5	56	45
HVK 9 EGM 18	HK 9 EGM 18	300	M18 x1.5	23.3	13.5	57	45
HVK 9 EG 21	HK 9 EG 21	300	BSP 1/2"	23.3	13.5	58	45
HVK 16 EG 21	HK 16 EG 21	500	BSP 1/2"	32	20.1	78	66
HVK 16 EG 26	HK 16 EG 26	500	BSP 3/4"	32	20.1	82	66



↻ / With Valve	← / Without Valve	Serie	Ø	Ød	Ød1	L
HVK 6 DG 10	HK 6 DG 10	200	BSP 1/8"	17	9.5	40
HVK 6 DG 13	HK 6 DG 13	200	BSP 1/4"	17	9.5	43.6
HVK 6 DGM 14	HK 6 DGM 14	200	M14x1.5	17	9.5	43.6
HVK 6 DG 17	HK 6 DG 17	200	BSP 3/8"	17	9.5	43.6
HVK 9 DG 13	HK 9 DG 13	300	BSP 1/4"	23.3	13.5	52
HVK 9 DG 17	HK 9 DG 17	300	BSP 3/8"	23.3	13.5	52
HVK 9 DG 21	HK 9 DG 21	300	BSP 1/2"	23.3	13.5	57
HVK 16 DG 21	HK 16 DG 21	500	BSP 1/2"	32	20.1	75

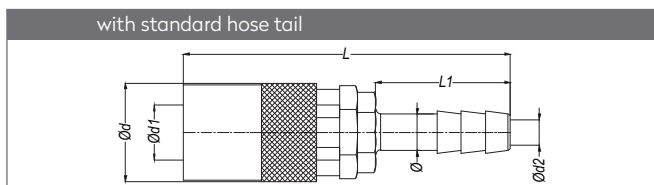

↻ / With Valve	Serie	Ø	Ød	Ød1	Ød2	L	L1
HVK 6-06	200	6.3-1/4"	17	9.5	4	56.5	23.3
HVK 6-08	200	8-5/16"	17	9.5	6	56.5	23.3
HVK 6-09	200	9-5/14"	17	9.5	7	56.5	23.3
HVK 6-10	200	10-3/8"	17	9.5	8	56.5	23.3
HVK 9-10	300	10-3/8"	23.3	13.5	8	61	25.3
HVK 9-11	300	11-7/16"	23.3	13.5	9	61	25.3
HVK 9-13	300	13-1/2"	23.3	13.5	10	61	25.3

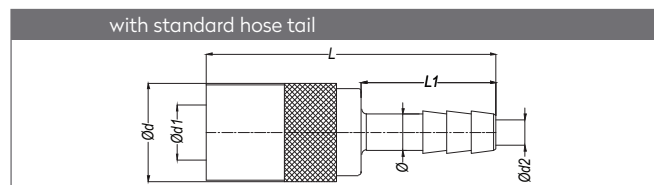

← / Without Valve	Serie	Ø	Ød	Ød1	Ød2	L	L1
HK 6-06	200	6.3-1/4"	17	9.5	4	56.5	23.3
HK 6-08	200	8-5/16"	17	9.5	6	56.5	23.3
HK 6-09	200	9-5/14"	17	9.5	7	56.5	23.3
HK 6-10	200	10-3/8"	17	9.5	8	56.5	23.3
HK 9-10	300	10-3/8"	23.3	13.5	8	61	25.3
HK 9-11	300	11-7/16"	23.3	13.5	9	61	25.3
HK 9-13	300	13-1/2"	23.3	13.5	10	61	25.3
HK 16-13	500	13-1/2"	32	20.1	10	93	27
HK 16-16	500	16-5/8"	32	20.1	13	93	27
HK 16-19	500	19-3/4"	32	20.1	16	93	27
HVK 16-13	500	13-1/2"	32	20.1	10	93	27
HVK 16-16	500	16-5/8"	32	20.1	13	93	27
HVK 16-19	500	19-3/4"	32	20.1	16	93	27

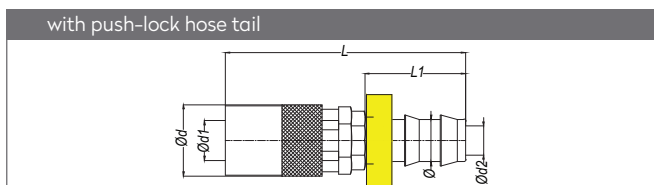

↻ / With Valve	Serie	Ø	Ød	Ød1	Ød2	L	L1
HVK 6 FG 06	200	6.7-1/4"	17	9.5	4.5	50	24
HVK 6 FG 10	200	10-3/8"	17	9.5	7.5	50	24
HVK 9 FG 10	300	10-3/8"	23.3	13.5	7.5	60	24
HVK 9 FG 13	300	13-1/2"	23.3	13.5	9	64	28

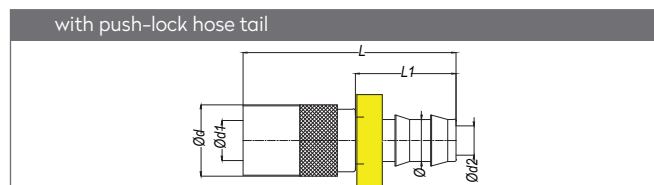

← / Without Valve	Serie	Ø	Ød	Ød1	Ød2	L	L1
HK 6 FG 06	200	6.7-1/4"	17	9.5	4.5	50	24
HK 6 FG 10	200	10-3/8"	17	9.5	7.5	50	24
HK 9 FG 10	300	10-3/8"	23.3	13.5	7.5	60	24
HK 9 FG 13	300	13-1/2"	23.3	13.5	9	64	28
HK 16 FG 13	500	13-1/2"	32	20.1	9	93	28
HK 16 FG 16	500	16-5/8"	32	20.1	13	103	38
HK 16 FG 19	500	19-3/4"	32	20.1	15	103	38
HVK 16 FG 13	500	13-1/2"	32	20.1	9	93	28
HVK 16 FG 16	500	16-5/8"	32	20.1	13	103	38
HVK 16 FG 19	500	19-3/4"	32	20.1	15	103	38

MOULD COOLING COUPLINGS
KÜHLUNGSELEMENTE FÜR WERKZEUGE

SERIE 6-9-16

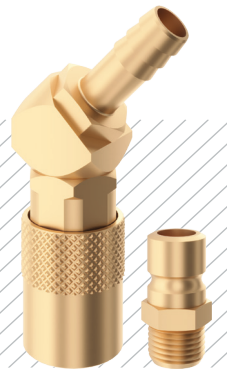

QUICK COUPLINGS SCHNELLKUPPLUNGEN

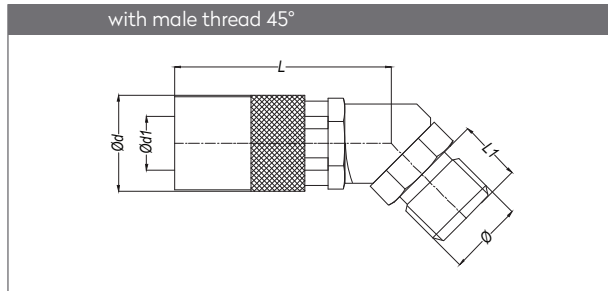

/ With Valve	/ Without Valve	Serie	Ø	Ød	Ød1	L	L1
HVK 6 EG 10-45°	HK 6 EG 10-45°	200	BSP 1/8"	17	9.5	38.2	9
HVK 6 EG 13-45°	HK 6 EG 13-45°	200	BSP 1/4"	17	9.5	38.2	11
HVK 9 EG 13-45°	HK 9 EG 13-45°	300	BSP 1/4"	23.3	13.5	49.8	11
HVK 9 EGM 16-45°	HK 9 EGM 16-45°	300	M16x1.5	23.3	13.5	49.8	11
HVK 9 EG 17-45°	HK 9 EG 17-45°	300	BSP 3/8"	23.3	13.5	49.8	11
HVK 9 EG 21-45°	HK 9 EG 21-45°	300	BSP 1/2"	23.3	13.5	49.8	11
HVK 16 EG 21-45°	HK 16 EG 21-45°	500	BSP 1/2"	32	20.1	73	12

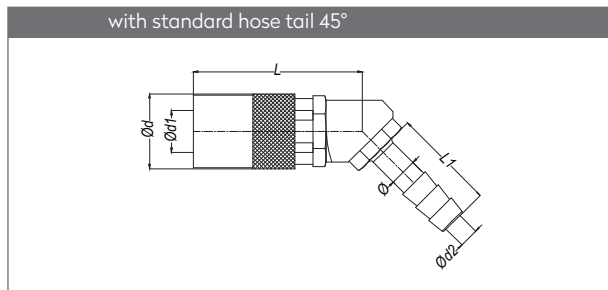

/ With Valve	/ Without Valve	Serie	Ø	Ød	Ød1	Ød2	L	L1
HVK 6-06-45°	HK 6-06-45°	200	6-1/4"	17	9.5	4	38.2	23.3
HVK 6-08-45°	HK 6-08-45°	200	8-5/16"	17	9.5	6	38.2	23.3
HVK 6-09-45°	HK 6-09-45°	200	9-5/14"	17	9.5	7	38.2	23.3
HVK 6-10-45°	HK6-10-45°	200	10-3/8"	17	9.5	8	38.2	23.3
HVK 9-10-45°	HK9-10-45°	300	10-3/8"	23.3	13.5	8	49.8	25.3
HVK 9-11-45°	HK 9-11-45°	300	11-7/16"	23.3	13.5	9	49.8	25.3
HVK 9-13-45°	HK9-13-45°	300	13-1/2"	23.3	13.5	10	49.8	25.3
HVK 16-13-45°	HK 16-13-45°	500	13-1/2"	32	20.1	12.8	73.5	27
HVK 16-16-45°	HK 16-16-45°	500	16-5/8"	32	20.1	15.5	73.5	27
HVK 16-19-45°	HK 16-19-45°	500	19-3/4"	32	20.1	18.5	73.5	27

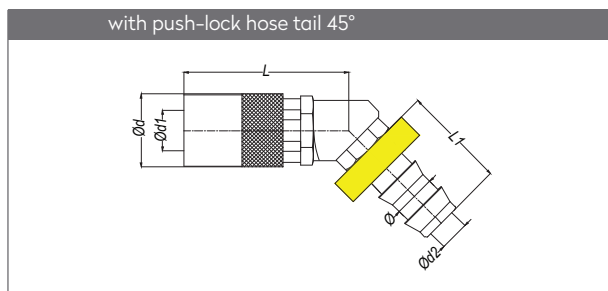

/ With Valve	/ Without Valve	Serie	Ø	Ød	Ød1	Ød2	L	L1
HVK 6 FG 06-45°	HK 6 FG 06-45°	200	6.7-1/4"	17	9.5	4.5	38.2	24
HVK 6 FG 10-45°	HK 6 FG 10-45°	200	10-3/8"	17	9.5	7.5	38.2	24
HVK 9 FG 10-45°	HK 9 FG 10-45°	300	10-3/8"	23.3	13.5	7.5	49.8	24
HVK 9 FG 13-45°	HK 9 FG 13-45°	300	13-1/2"	23.3	13.5	10	49.8	28
HVK 16 FG 13-45°	HK16 FG 13-45°	500	13.3-1/2"	32	20.1	9	73.5	28
HVK 16 FG 16-45°	HK16 FG 16-45°	500	16-5/8"	32	20.1	13	73.5	38
HVK 16 FG 19-45°	HK16 FG 19-45°	500	19-3/4"	32	20.1	15	73.5	38



 MOULD COOLING COUPLINGS
 KÜHLUNGSELEMENTE FÜR WERKZEUGE

SERIE 6-9-16

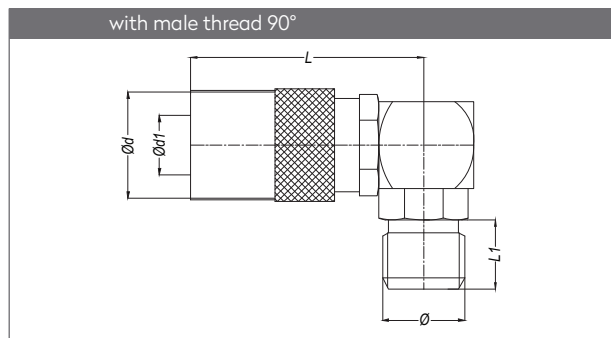
QUICK COUPLINGS SCHNELLKUPPLUNGEN

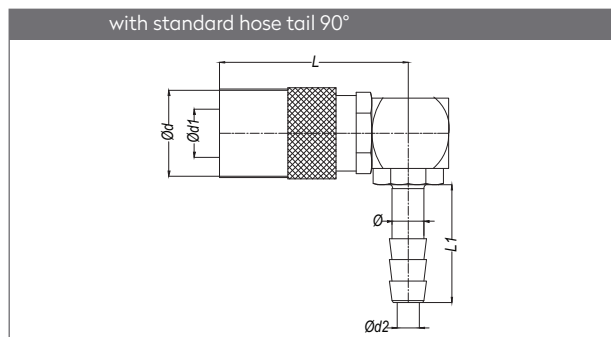

↻ / With Valve	← / Without Valve	Serie	Ø	Ød	Ød1	L	L1
HVK 6 EG 10-90°	HK 6 EG 10-90°	200	BSP 1/8"	17	9.5	37.2	9
HVK 6 EG 13-90°	HK 6 EG 13-90°	200	BSP 1/4"	17	9.5	37.2	11
HVK 9 EG 13-90°	HK 9 EG 13-90°	300	BSP 1/4"	23.3	13.5	50	11
HVK 9 EGM 16-90°	HK 9 EGM 16-90°	300	M16x1.5	23.3	13.5	50	11
HVK 9 EG 17-90°	HK 9 EG 17-90°	300	BSP 3/8"	23.3	13.5	50	11
HVK 9 EG 21-90°	HK 9 EG 21-90°	300	BSP 1/2"	23.3	13.5	50	11
HVK 16 EG 21-90°	HK 16 EG 21-90°	500	BSP 1/2"	32	20.1	73.5	12



↻ / With Valve	← / Without Valve	Serie	Ø	Ød	Ød1	Ød2	L	L1
HVK 6-06-90°	HK 6-06-90°	200	6-1/4"	17	9.5	4	37.2	23.3
HVK 6-08-90°	HK 6-08-90°	200	8-5/16"	17	9.5	6	37.2	23.3
HVK 6-09-90°	HK 6-09-90°	200	9-5/14"	17	9.5	7	37.2	23.3
HVK 6-10-90°	HK 6-10-90°	200	10-3/8"	17	9.5	8	37.2	23.3
HVK 9-10-90°	HK 9-10-90°	300	10-3/8"	23.3	13.5	8	50	25.3
HVK 9-11-90°	HK 9-11-90°	300	11-7/16"	23.3	13.5	9	50	25.3
HVK 9-13-90°	HK 9-13-90°	300	13-1/2"	23.3	13.5	10	50	25.3
HVK 16-13-90°	HK 16-13-90°	500	13-1/2"	32	20.1	12.8	73	27
HVK 16-16-90°	HK 16-16-90°	500	16-5/8"	32	20.1	15.5	73	27
HVK 16-19-90°	HK 16-19-90°	500	19-3/4"	32	20.1	16.5	73	27

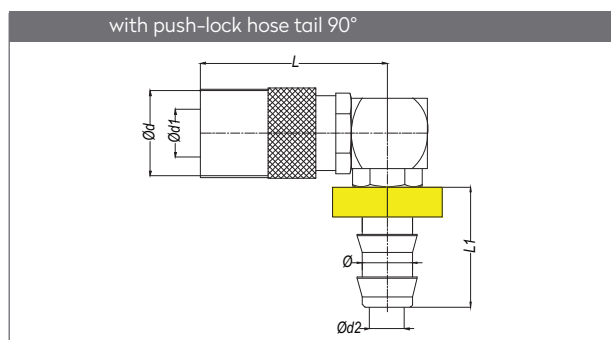

↻ / With Valve	← / Without Valve	Serie	Ø	Ød	Ød1	Ød2	L	L1
HVK 6 FG 06-90°	HK 6 FG 06-90°	200	6.7-1/4"	17	9.5	4.5	37.3	24
HVK 6 FG 10-90°	HK 6 FG 10-90°	200	10-3/8"	17	9.5	7.5	37.2	24
HVK 9 FG 10-90°	HK 9 FG 10-90°	300	10-3/8"	23.3	13.5	7.5	50	24
HVK 9 FG 13-90°	HK 9 FG 13-90°	300	13-1/2"	23.3	13.5	10	50	28
HVK 16 FG 13-90°	HK 16 FG 13-90°	500	13.3-1/2"	32	20.1	9	73	28
HVK 16 FG 16-90°	HK 16 FG 16-90°	500	16-5/8"	32	20.1	13	73	38
HVK 16 FG 19-90°	HK 16 FG 19-90°	500	19-3/4"	32	20.1	15	73	38

MOULD COOLING COUPLINGS
KÜHLUNGSELEMENTE FÜR WERKZEUGE

SERIE 6-9-16

QUICK COUPLINGS SCHNELLKUPPLUNGEN & PLUGS STECKNIPPEL

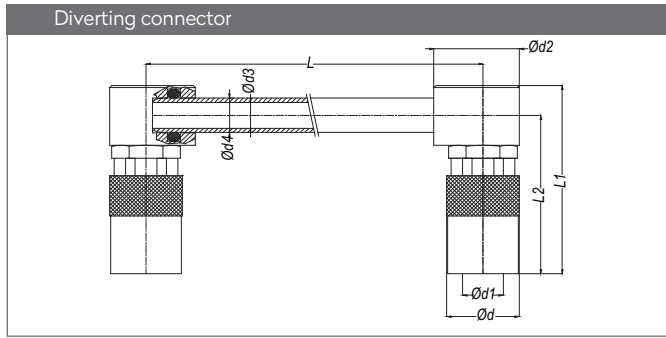

		↻	←									
With Valve	Without Valve	Serie	Ød	Ød1	Ød2	Ød3	Ød4	L	L1	L2		
HVK 6 - KG 125	HK 6 - KG 125	200	17	9.5	20	6	8	125	37	44.2		
HVK 6 - KG 250	HK 6 - KG 250	200	17	9.5	20	6	8	250	37	44.2		
HVK 6 - KG 500	HK 6 - KG 500	200	17	9.5	20	6	8	500	37	44.2		
HVK 9 - KG 125	HK 9 - KG 125	300	23.3	13.5	26	8	10	125	48.5	57		
HVK 9 - KG 250	HK 9 - KG 250	300	23.3	13.5	26	8	10	250	48.5	57		
HVK 9 - KG 500	HK 9 - KG 500	300	23.3	13.5	26	8	10	500	48.5	57		
HVK 16 - KG 160	HK 16 - KG 160	500	32	20.1	36	12	14	160	70.8	83.8		
HVK 16 - KG 315	HK 16 - KG 315	500	32	20.1	36	12	14	315	70.8	83.8		
HVK 16 - KG 500	HK 16 - KG 500	500	32	20.1	36	12	14	500	70.8	83.8		

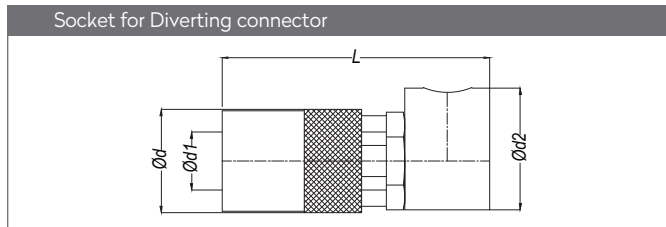

Part No.	Serie	Ød1	L	Ød	Ød2
HVK 6 KG 00	HK 6 KG 00	200	9.5	44.2	17
HVK 9 KG 00	HK 9 KG 00	300	13.5	57	23.3
HVK 16 KG 00	HK 16 KG 00	500	20.1	83.8	32

Part No. for the brass tube	Outer Ød	Thickness
060 KPB x Length	8	1
090 KPB x Length	10	1

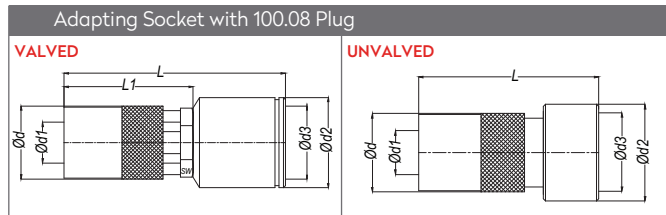

		↻	←									
With Valve	Without Valve	Serie	Ød	Ød1	Ød2	Ød3	L	L1	SW			
HVK 6 AU 100.08	-	200	17	9.5	21	17	51.6	30.1	14			
HVK 9 AU 100.08	-	300	23.3	13.5	21	17	52	40	19			
-	HK 6 AU 100.08	200	17	9.5	21	17	49	-	-			
-	HK 9 AU 100.08	300	23.3	13.5	21	17	48	-	-			

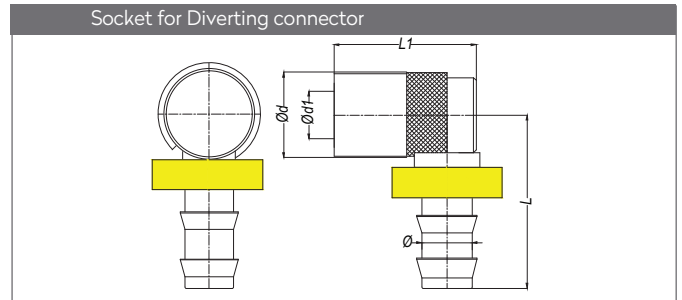

Part No.	Serie	Ø	L	L1	Ød	Ød1
HVK 6 KG 10	HK 6 KG 10	200	10 - 3/8"	34.5	28.3	17
HVK 9 KG 13	HK 9 KG 13	300	13 - 1/2"	41	36.3	23.3

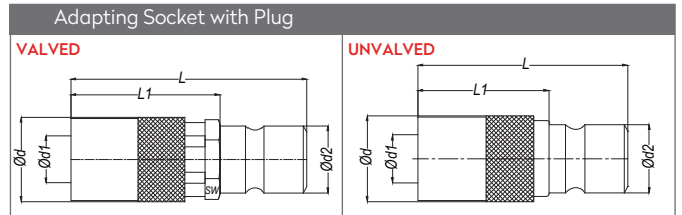

		↻	←								
With Valve	Without Valve	Serie	Ød	Ød1	Ød2	L	L1	SW			
HVK 6 AU 009	-	200	17	9.5	13.5	47.6	30.1	14			
HVK 9 AU 006	-	300	23.3	13.5	9.5	53	42.3	19			
-	HK 6 AU 009	200	17	9.5	13.5	41.6	26	-			
-	HK 9 AU 006	300	23.3	13.5	9.5	51	40	-			

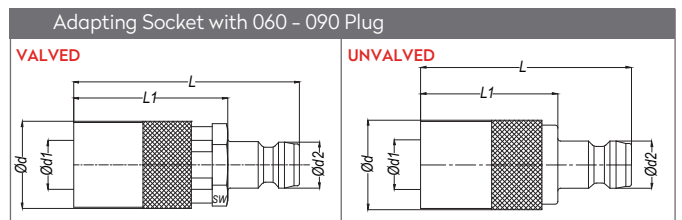

		↻	←									
With Valve	Without Valve	Serie	Ød	Ød1	Ød2	L	L1	SW				
HVK 6 AU 090	-	200	17	9.5	13.5	46	30.1	14				
HVK 9 AU 060	-	300	23.3	13.5	9.5	56.5	42.3	19				
-	HK 6 AU 090	200	17	9.5	9.5	40	26	-				
-	HK 9 AU 060	300	23.3	13.5	13.5	50	36.2	-				

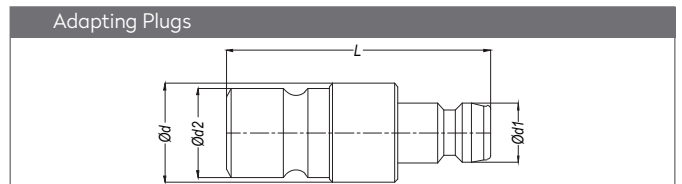

Part No.	Ød	Ød1	Ød2	L
006 HEF 00	11	9.4	9.4	30
009 HEF 00	15	13.5	13.5	40
006 HEF 009	15	9.4	13.5	35
006 HEF 060	11	9	9.4	35
009 HEF 090	15	13.5	13.5	40

MOULD COOLING COUPLINGS

KÜHLUNGSELEMENTE FÜR WERKZEUGE

SERIE 6-9-16

PLUGS STECKNIPPEL

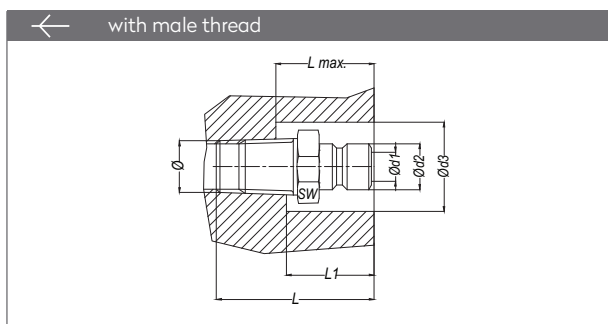

Part no.		Serie	Ø	Ød1	Ød2	Ød3	SW	L1	L _{max}	L _{BSPT}	L _{NPT}
BSPT	NPT										
6 RU 10	6 TU 10	200	1/8"	6	9.4	22	11	17	18	24	24
6 RU 13	6 TU 13	200	1/4"	6	9.4	26	14	19	18	27	27
6 RU 17	6 TU 17	200	3/8"	6	9.4	30	17	21	22	27	27
6 RU 21	6 TU 21	200	1/2"	6	9.4	34	22	22	22	32	32
9 RU 10	9 TU 10	300	1/8"	9	13.5	26	14	26	24	29.5	29.5
9 RU 13	9 TU 13	300	1/4"	9	13.5	26	14	25	26	32.5	33
9 RU 17	9 TU 17	300	3/8"	9	13.5	30	17	26	28	32.5	34
9 RU 21	9 TU 21	300	1/2"	9	13.5	34	22	26	28	37	37
9 RU 26	9 TU 26	300	3/4"	9	13.5	30	17	26	36	42.5	42.5
16 RU 13	16 TU 13	500	1/4"	15	20	32	21	24.5	28	36.5	36.5
16 RU 17	16 TU 17	500	3/8"	15	20	32	21	24.5	29	37.5	37.5
16 RU 21	16 TU 21	500	1/2"	15	20	32	22	25.5	36	42.5	42.5
16 RU 26	16 TU 26	500	3/4"	15	20	32	27	26	36	43.8	43.8

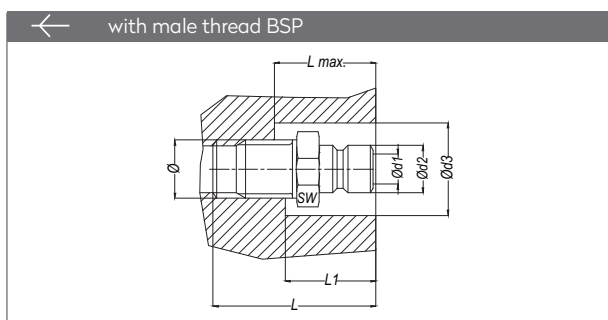

Part no.	Serie	Ø	Ød1	Ød2	Ød3	SW	L	L1	L _{max}
6 EU 10	200	1/8"	6	9.4	22	11	22	17	18
6 EU 13	200	1/4"	6	9.4	26	14	27	19	18
6 EU 17	200	3/8"	6	9.4	30	17	27	21	22
9 EU 10	300	1/8"	9	13.5	26	14	27.5	25	25
9 EU 13	300	1/4"	9	13.5	26	14	29.5	25	25
9 EU 17	300	3/8"	9	13.5	32	19	29.5	26	26
9 EU 21	300	1/2"	9	13.5	34	22	32	26	26
16 EU 17	500	3/8"	15	20	36	21	35	26	26
16 EU 21	500	1/2"	15	20	37	22	37.5	25.5	25.5
6 EUM 10	200	M10x1	6	9.4	22	11	24	14	16
6 EUM 14	200	M14x1.5	6	9.4	26	15	25	14	16
9 EUM 10	300	M10x1	9	13.5	26	14	29.5	20	20
9 EUM 12	300	M12x1.5	9	13.5	26	14	29.5	20	20
9 EUM 14	300	M14x1.5	9	13.5	30	15	29.5	20	20

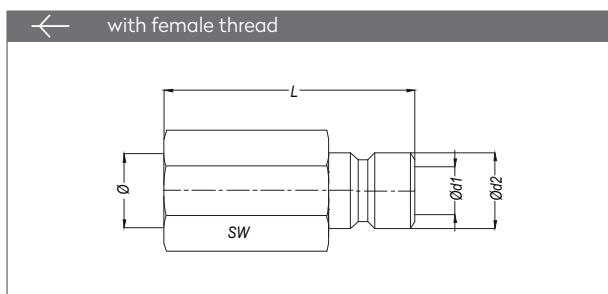

Part no.		Serie	Ø	Ød1	Ød2	L	SW
BSPT	NPT						
6 DU 10	6 NU 10	200	1/8"	6	9.4	25.5	13
6 DU 13	6 NU 13	200	1/4"	6	9.4	32	16
6 DU 17	6 NU 17	200	3/8"	6	9.4	32	19
9 DU 10	9 NU 10	300	1/8"	9	13.5	29	14
9 DU 13	9 NU 13	300	1/4"	9	13.5	37	16
9 DU 17	9 NU 17	300	3/8"	9	13.5	39	19
9 DU 21	9 NU 21	300	1/2"	9	13.5	40	24
16 DU 17	16 NU 17	500	3/8"	15	20	34.5	24
16 DU 21	16 NU 21	500	1/2"	15	20	34.5	24

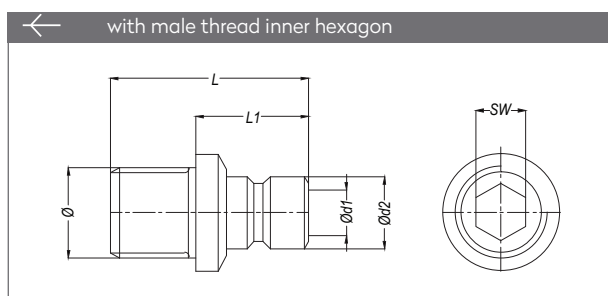

Part no.	Serie	Ø	Ød1	Ød2	L	L1	SW
6 AUG 13	200	1/4"	6	9.4	22.7	13.7	5
9 AUG 13	300	1/4"	9	13.5	30	20	8
9 AUG 17	300	3/8"	9	13.5	37	20.5	8

SERIE 6-9-16



PLUGS STECKNIPPEL

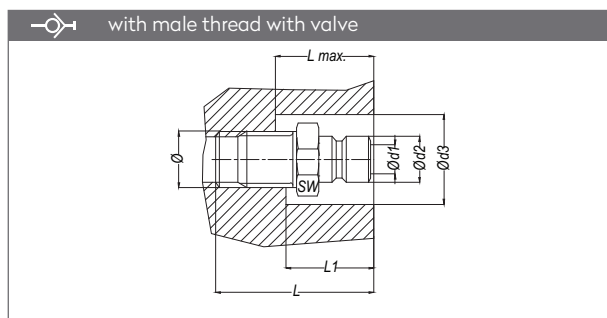
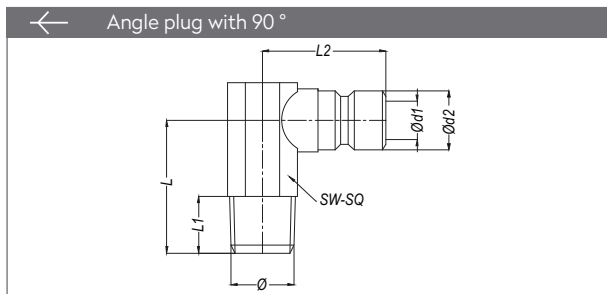
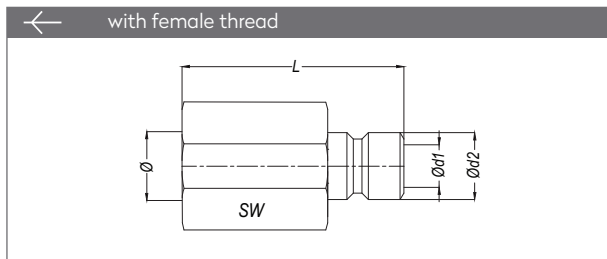
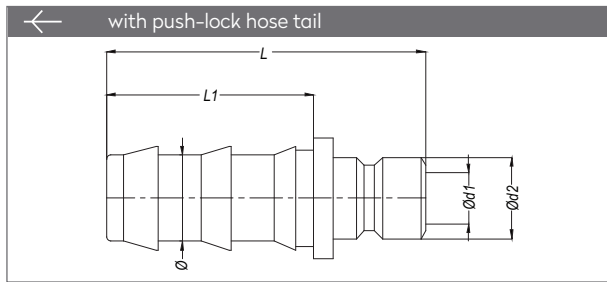
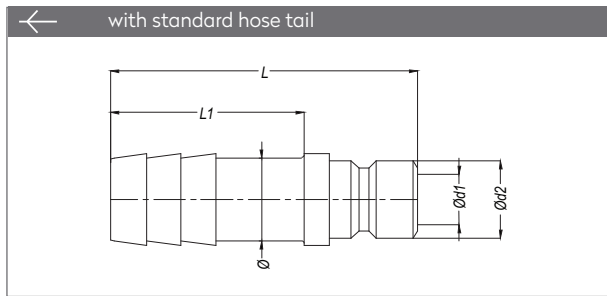

Part no.	Serie	Ø	Ød1	Ød2	L	L1
6 HU 06	200	6.3-1/4"	6	9.4	37	23.3
6 HU 08	200	8-5/16"	6	9.4	37	23.3
6 HU 09	200	9-5/14"	6	9.4	37	23.3
6 HU 10	200	10-3/8"	6	9.4	37	23.3
9 HU 09	300	9-5/14"	9	13.5	45	25.3
9 HU 10	300	10-3/8"	9	13.5	45	25.3
9 HU 11	300	11-7/16"	9	13.5	45	25.3
9 HU 13	300	13-1/4"	9	13.5	45	25.3
16 HU 13	500	13-1/4"	15	19.9	50	27
16 HU 19	500	19-3/4"	15	19.9	50	27

Part no.	Serie	Ø	Ød1	Ød2	L	L1
6 FU 10	200	10-3/8"	6	9.4	24	37
6 FU 13	200	13-1/2"	6	9.4	28	41
9 FU 06	300	6.3-1/2"	9	13.5	24	45
9 FU 10	300	10-3/8"	9	13.5	24	45
9 FU 13	300	13-1/2"	9	13.5	28	48
16 FU 19	500	19-3/4"	15	19.9	38	65

Part no.	Ø	Ød1	Ød2	SW	L1
006 DUB 10	BSP 1/8"	6	9.4	16	40.5
006 DUB 13	BSP 1/4"	6	9.4	19	40.5
009 DUB 13	BSP 1/4"	9	13.5	16	42.5
009 DUB 17	BSP 3/8"	9	13.5	19	42.5
009 DUB 21	BSP 1/2"	9	13.5	24	44.5
016 DUB 21	BSP 1/2"	15	20	24	62

Part no.	Serie	Ø	Ød1	Ød2	L	L1	L2	SW /SQ
6 RU 10 - 90	200	BSPT 1/8"	6	9.4	27	9	19.5	11
6 EUM 10 - 90	200	M10x1	6	9.4	27	9	19.5	11
6 RU 13 - 90	200	BSPT 1/4"	6	9.4	34	11	21.5	15
6 EUM 14 - 90	200	M14x1.5	6	9.4	34	11	21.5	15
6 RU 17 - 90	200	BSPT 3/8"	6	9.4	34	12	27	17
9 RU 13 - 90	300	BSPT 1/4"	9	13.5	34	11	27	15
9 RU 17 - 90	300	BSPT 3/8"	9	13.5	34	12	27.2	17

Part no.		Serie	Ø	Ød1	Ød2	Ød3	L	L1	L _{max}	SW
BSPT	NPT									
6 RUB 13	6 TUB 13	200	1/4"	6	9.4	26	29	15	24	14
6 RUB 17	6 TUB 17	200	3/8"	6	9.4	30	29	15	24	17
9 RUB 13	9 TUB 13	300	1/4"	9	13.5	26	32.5	20.5	24	14
9 RUB 17	9 TUB 17	300	3/8"	9	13.5	30	32.5	20.5	24	17
9 RUB 21	9 TUB 21	300	1/2"	9	13.5	37	37	21	30	22
16 RUB 21	16 TUB 21	500	1/2"	15	20	32	45.5	26.7	36	22
16 RUB 26	16 TUB 26	500	3/4"	15	20	32	45.5	26.7	36	27

Part no.	Serie	Ø	Ød1	Ød2	Ød3	L	L1	L _{max}	SW
6 EUBM 10	200	M10x1	6	9.4	26	28.5	18	22	14
6 EUBM 14	200	M14x1.5	6	9.4	26	29	15	15	14
9 EUBM 14	300	M14x1.5	9	13.5	26	30	20	20	14

MOULD COOLING COUPLINGS

KÜHLUNGSELEMENTE FÜR WERKZEUGE

SERIE 6-9-16

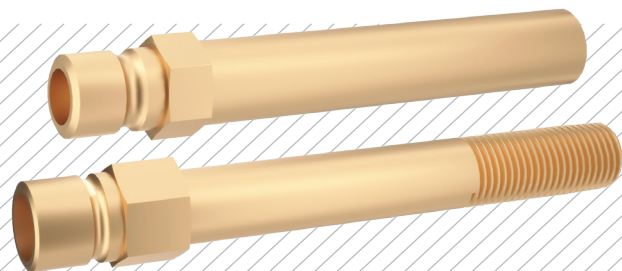

PLUGS STECKNIPPEL

- Extension Plugs with tapered and long parallel thread
Verlängerungsniessel mit Aussengewinde konisch
- The largest complete thread on the standard NPT or BSPT taper is continued along the extension plug for the 1 5/8" (41 mm) shown below easy adjustments if needed.
Die erste Gewindestufe der konisch ausgeführten Niessel ermöglicht einen sehr flexiblen Einsatzbereich

Serie	Ød1	Ød2
200	6	9.4
300	9	13.5
500	15	19.9

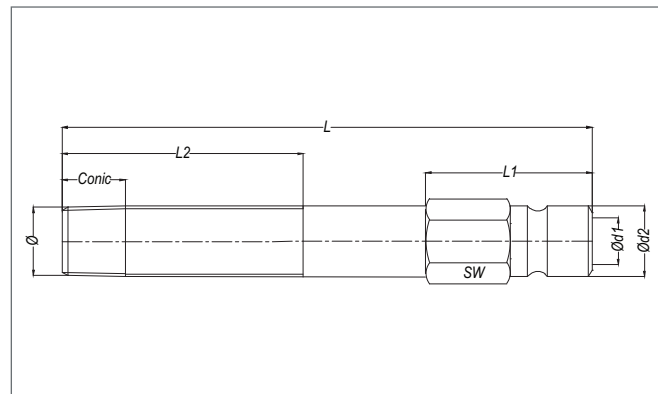

Serie & Thread	Part No.		L	L1	L2	SW
	NPT	BSPT				
200 1/8"	6 NL 10x63	6 RL 10x63	63.5	21.2	41	11
	6 NL 10x101	6 RL 10x101	101.6	25.4	41	11
	6 NL 10x140	6 RL 10x140	140	25.4	41	11
	6 NL 10x178	6 RL 10x178	178	25.4	41	11
	6 NL 10x216	6 RL 10x216	216	25.4	41	11
	6 NL 10x254	6 RL 10x254	254	25.4	41	11
	6 NL 10x292	6 RL 10x292	292	25.4	41	11
200 1/4"	6 NL 10x330	6 RL 10x330	330	25.4	41	11
	6 NL 13x63	6 RL 13x63	63.5	22.2	41	14
	6 NL 13x101	6 RL 13x101	101.6	31.7	41	14
	6 NL 13x140	6 RL 13x140	140	31.7	41	14
	6 NL 13x178	6 RL 13x178	178	31.7	41	14
	6 NL 13x216	6 RL 13x216	216	31.7	41	14
	6 NL 13x254	6 RL 13x254	254	31.7	41	14
200 3/8"	6 NL 13x292	6 RL 13x292	292	31.7	41	14
	6 NL 13x330	6 RL 13x330	330	31.7	41	14
	6 NL 17x63	6 RL 17x63	63.5	25.4	41	17
	6 NL 17x101	6 RL 17x101	101.6	31.7	41	17
	6 NL 17x140	6 RL 17x140	140	31.7	41	17
	6 NL 17x178	6 RL 17x178	178	31.7	41	17
	6 NL 17x216	6 RL 17x216	216	31.7	41	17
300 1/8"	6 NL 17x254	6 RL 17x254	254	31.7	41	17
	6 NL 17x292	6 RL 17x292	292	31.7	41	17
	6 NL 17x330	6 RL 17x330	330	31.7	41	17
	9 NL 10x63	9 RL 10x63	63.5	21	38.1	14
	9 NL 10x101	9 RL 10x101	101.6	22.2	41.5	14
	9 NL 10x140	9 RL 10x140	140	25.4	41.5	14
	9 NL 10x178	9 RL 10x178	178	25.4	41.5	14
300 3/8"	9 NL 10x216	9 RL 10x216	216	25.4	41.5	14
	9 NL 10x254	9 RL 10x254	254	25.4	41.5	14
	9 NL 10x292	9 RL 10x292	292	25.4	41.5	14
	9 NL 10x330	9 RL 10x330	330	25.4	41.5	14
	16 NL 17x63	16 RL 17x63	63.5	25.4	42	21
	16 NL 17x101	16 RL 17x101	101.6	38.1	42	21
	16 NL 17x140	16 RL 17x140	140	38.1	42	21
500 1/2"	16 NL 17x178	16 RL 17x178	178	38.1	42	21
	16 NL 17x216	16 RL 17x216	216	38.1	42	21
	16 NL 17x254	16 RL 17x254	254	38.1	42	21
	16 NL 17x292	16 RL 17x292	292	38.1	42	21
	16 NL 17x330	16 RL 17x330	330	38.1	42	21
	16 NL 21x63	16 RL 21x63	63.5	25.4	42	22
	16 NL 21x101	16 RL 21x101	101.6	38.1	42	22
500 3/8"	16 NL 21x140	16 RL 21x140	140	38.1	42	22
	16 NL 21x178	16 RL 21x178	178	38.1	42	22
	16 NL 21x216	16 RL 21x216	216	38.1	42	22
	16 NL 21x254	16 RL 21x254	254	38.1	42	22
	16 NL 21x292	16 RL 21x292	292	38.1	42	22
	16 NL 21x330	16 RL 21x330	330	38.1	42	22
	16 NL 21x330	16 RL 21x330	330	38.1	42	22

Serie & Thread	Part No.		L	L1	L2	SW _{NPT}	SW _{BSPT}
	NPT	BSPT					
300 1/4"	9 NL 13x63	9 RL 13x63	63.5	22.2	41.5	14	14
	9 NL 13x101	9 RL 13x101	101.6	31.7	41.5	14	14
	9 NL 13x140	9 RL 13x140	140	31.7	41.5	15	14
	9 NL 13x178	9 RL 13x178	178	31.7	41.5	15	14
	9 NL 13x216	9 RL 13x216	216	31.7	41.5	15	14
	9 NL 13x254	9 RL 13x254	254	31.7	41.5	15	14
	9 NL 13x292	9 RL 13x292	292	31.7	41.5	15	14
300 3/8"	9 NL 13x330	9 RL 13x330	330	31.7	41.5	15	14
	9 NL 17x63	9 RL 17x63	63.5	25.4	38.1	17	17
	9 NL 17x101	9 RL 17x101	101.6	31.7	38.1	17	17
	9 NL 17x140	9 RL 17x140	140	31.7	38.1	17	17
	9 NL 17x178	9 RL 17x178	178	31.7	38.1	17	17
	9 NL 17x216	9 RL 17x216	216	31.7	38.1	17	17
	9 NL 17x254	9 RL 17x254	254	31.7	38.1	17	17
300 1/2"	9 NL 17x292	9 RL 17x292	292	31.7	38.1	17	17
	9 NL 17x330	9 RL 17x330	330	31.7	41.5	17	17
	9 NL 21x63	9 RL 21x63	63.5	25.4	38.1	22	22
	9 NL 21x101	9 RL 21x101	101.6	31.7	38.1	22	22
	9 NL 21x140	9 RL 21x140	140	31.7	38.1	22	22
	9 NL 21x178	9 RL 21x178	178	31.7	38.1	22	22
	9 NL 21x216	9 RL 21x216	216	31.7	38.1	22	22
500 3/8"	9 NL 21x254	9 RL 21x254	254	31.7	38.1	22	22
	9 NL 21x292	9 RL 21x292	292	31.7	38.1	22	22
	9 NL 21x330	9 RL 21x330	330	31.7	38.1	22	22
	16 NL 17x63	16 RL 17x63	63.5	25.4	42	21	21
	16 NL 17x101	16 RL 17x101	101.6	38.1	42	21	21
	16 NL 17x140	16 RL 17x140	140	38.1	42	21	21
	16 NL 17x178	16 RL 17x178	178	38.1	42	21	21
500 1/2"	16 NL 17x216	16 RL 17x216	216	38.1	42	21	21
	16 NL 17x254	16 RL 17x254	254	38.1	42	21	21
	16 NL 17x292	16 RL 17x292	292	38.1	42	21	21
	16 NL 17x330	16 RL 17x330	330	38.1	42	21	21
	16 NL 21x63	16 RL 21x63	63.5	25.4	42	22	22
	16 NL 21x101	16 RL 21x101	101.6	38.1	42	22	22
	16 NL 21x140	16 RL 21x140	140	38.1	42	22	22
500 1/2"	16 NL 21x178	16 RL 21x178	178	38.1	42	22	22
	16 NL 21x216	16 RL 21x216	216	38.1	42	22	22
	16 NL 21x254	16 RL 21x254	254	38.1	42	22	22
	16 NL 21x292	16 RL 21x292	292	38.1	42	22	22
	16 NL 21x330	16 RL 21x330	330	38.1	42	22	22
	16 NL 21x330	16 RL 21x330	330	38.1	42	22	22
	16 NL 21x330	16 RL 21x330	330	38.1	42	22	22

MOULD COOLING COUPLINGS
KÜHLUNGSELEMENTE FÜR WERKZEUGE

SERIE 6-9-16

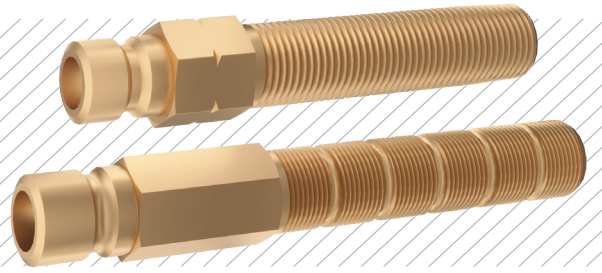

PLUGS STECKNIPPEL

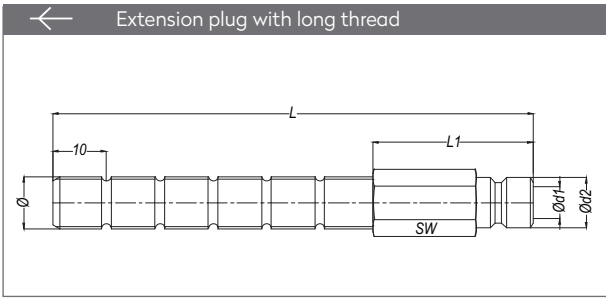

Part no.	Serie	Ø	Ød1	Ød2	SW	L	L1
6 BLM 10x100	200	M10x1	6	9.4	11	100	40
6 BL 10x100	200	BSP 1/8"	6	9.4	11	100	40
6 BL 13x100	200	BSP 1/4"	6	9.4	14	100	40
6 BLM 14x100	200	M14x1.5	6	9.4	14	100	40
6 BL 17x100	200	BSP 3/8"	6	9.4	17	100	40
9 BLM 10x100	300	M10x1	9	13.5	14	100	40
9 BL 10x100	300	BSP 1/8"	9	13.5	14	100	40
9 BL 13x100	300	BSP 1/4"	9	13.5	14	100	40
9 BLM 14x100	300	M14x1.5	9	13.5	14	100	40
9 BLM 16x100	300	M16x1.5	9	13.5	16	100	40
9 BL 17x100	300	BSP 3/8"	9	13.5	17	100	40

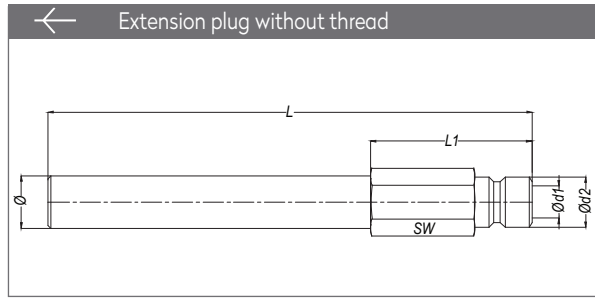

Part no.	Serie	Ø	Ød1	Ød2	SW	L	L1
6 BN 63	200	10	6	9.4	11	63	17
6 BN 100	200	10	6	9.4	11	100	17
6 BN 120	200	10	6	9.4	11	120	17
6 BN 240	200	10	6	9.4	11	240	17
6 BN 360	200	10	6	9.4	11	360	17
9 BN 150	300	14	9	13.5	15	150	23.5
9 BN 300	300	14	9	13.5	15	300	23.5
9 BN 450	300	14	9	13.5	15	450	24

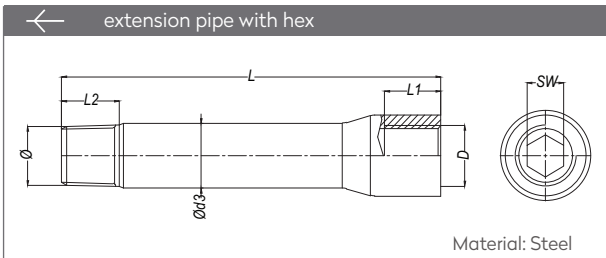

Part no.	D	Ø	Ød3	L	L1	L2	SW
R 10 BU 50	BSP 1/8"	BSPT 1/8"	10	50	9	10	5
R 10 BU 75	BSP 1/8"	BSPT 1/8"	10	75	9	10	5
R 10 BU 100	BSP 1/8"	BSPT 1/8"	10	100	9	10	5
R 10 BU 125	BSP 1/8"	BSPT 1/8"	10	125	9	10	5
R 10 BU 150	BSP 1/8"	BSPT 1/8"	10	150	9	10	5
N 10 BU 50	NPT 1/8"	NPSF 1/8"	10	50	9	10	5
N 10 BU 75	NPT 1/8"	NPSF 1/8"	10	75	9	10	5
N 10 BU 100	NPT 1/8"	NPSF 1/8"	10	100	9	10	5
N 10 BU 125	NPT 1/8"	NPSF 1/8"	10	125	9	10	5
N 10 BU 150	NPT 1/8"	NPSF 1/8"	10	150	9	10	5
R 13 BU 50	BSP 1/4"	BSPT 1/4"	14	50	12	11	8
R 13 BU 75	BSP 1/4"	BSPT 1/4"	14	75	12	11	8
R 13 BU 100	BSP 1/4"	BSPT 1/4"	14	100	12	11	8
R 13 BU 125	BSP 1/4"	BSPT 1/4"	14	125	12	11	8
R 13 BU 150	BSP 1/4"	BSPT 1/4"	14	150	12	11	8
R 13 BU 200	BSP 1/4"	BSPT 1/4"	14	200	12	11	8
N 13 BU 50	BSP 1/4"	NPT 1/4"	14	50	12	11	8
N 13 BU 75	BSP 1/4"	NPT 1/4"	14	75	12	11	8
R 13 BU 100	BSP 1/4"	NPT 1/4"	14	100	12	11	8
R 13 BU 125	BSP 1/4"	NPT 1/4"	14	125	12	11	8
R 13 BU 150	BSP 1/4"	NPT 1/4"	14	150	12	11	8
R 13 BU 200	BSP 1/4"	NPT 1/4"	14	200	12	11	8

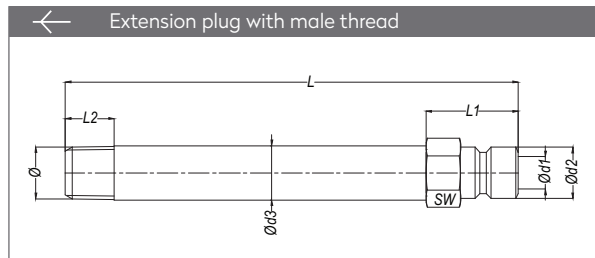

Part no.		Serie	Ø	SW	Ød1	Ød2	Ød3	L1	L2	L50	L100	L150	L200	L250
BSPT	NPT													
6 RU 10xL	6 TU 10xL	200	1/8"	11	6	9.4	10	17	9	50	100	150	200	250
6 RU 13xL	6 TU 13xL	200	1/4"	14	6	9.4	14	17	12	50	100	150	200	250
6 RU 17xL	6 TU 17xL	200	3/8"	17	6	9.4	16.8	17	12	50	100	150	200	250
9 RU 10xL	9 TU 10xL	300	1/8"	14	9	13.5	10	24	9	50	100	150	200	250
9 RU 13xL	9 TU 13xL	300	1/4"	15	9	13.5	14	24	12	50	100	150	200	250
9 RU 17xL	9 TU 17xL	300	3/8"	17	9	13.5	16.8	24	12	50	100	150	200	250
9 RU 21xL	9 TU 21xL	300	1/2"	22	9	13.5	21.4	24	14	50	100	150	200	250
Part No.	Serie	Ø	SW	Ød1	Ød2	Ød3	L1	L2	L50	L100	L150	L200	L250	
6 EUM 10xL	200	M10x1	11	6	9	10	17	9	50	100	150	200	250	
6 EUM 14xL	200	M14x1.5	15	6	9	14	17	12	50	100	150	200	250	
9 EUM 14xL	300	M14x1.5	15	9	13	14	24	12	50	100	150	200	250	

MOULD COOLING COUPLINGS

KÜHLUNGSELEMENTE FÜR WERKZEUGE

SERIE 6-9-16

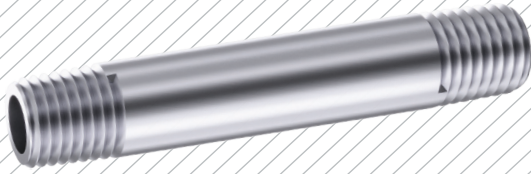

PLUGS STECKNIPPEL

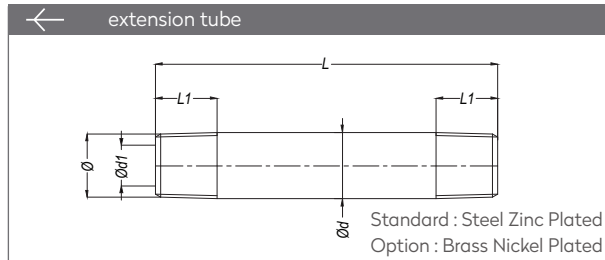

Part no.		Ø	Ød	Ød1	L	L1
BSPT	NPT					
6 BU 50	6 NBU 50	1/8"	10	6	50	9
6 BU 100	6 NBU 100	1/8"	10	6	100	9
6 BU 150	6 NBU 150	1/8"	10	6	150	9
6 BU 200	6 NBU 200	1/8"	10	6	200	9
6 BU 250	6 NBU 250	1/8"	10	6	250	9
6 BU 300	6 NBU 300	1/8"	10	6	300	9
9 BU 50	9 NBU 50	1/4"	14	9	50	11
9 BU 100	9 NBU 100	1/4"	14	9	100	11
9 BU 150	9 NBU 150	1/4"	14	9	150	11
9 BU 200	9 NBU 200	1/4"	14	9	200	11
9 BU 250	9 NBU 250	1/4"	14	9	250	11
9 BU 300	9 NBU 300	1/4"	14	9	300	11
9 BU 350	9 NBU 350	1/4"	14	9	350	11
12 BU 30	12 NBU 30	3/8"	17	12	30	12
12 BU 350	12 NBU 350	3/8"	17	12	350	12
16 BU 100	16 NBU 100	1/2"	22	16	100	15
16 BU 150	16 NBU 150	1/2"	22	16	150	15
16 BU 200	16 NBU 200	1/2"	22	16	200	15
16 BU 250	16 NBU 250	1/2"	22	16	250	15

ACCESSORIES ZUBEHÖR



Part No.	Serie	Temperature
006GC00M	200	
009GC00M	300	-40°C to + 100°C
016GC00M	500	

Part No.	Serie	Temperature
006GC00V	200	
009GC00V	300	-26°C to + 200°C
016GC00V	500	

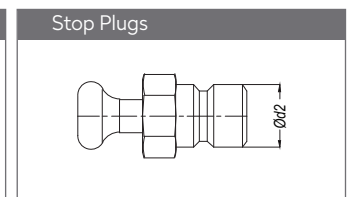
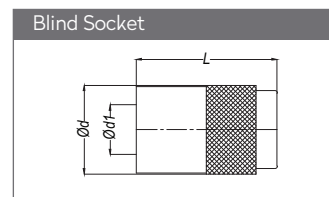

Part No.	Serie	Ød	Ød1	L
6 KTG 00	200	17	9.5	27
9 KTG 00	300	23.3	13.5	36
16 KTG 00	500	32	20.1	44.5

Part No.	Serie	Ød2
6 KTU 00	200 (1/4")	9.4
9 KTU 00	300 (3/8")	13.5
16 KTU 00	500 (1/2")	19.9

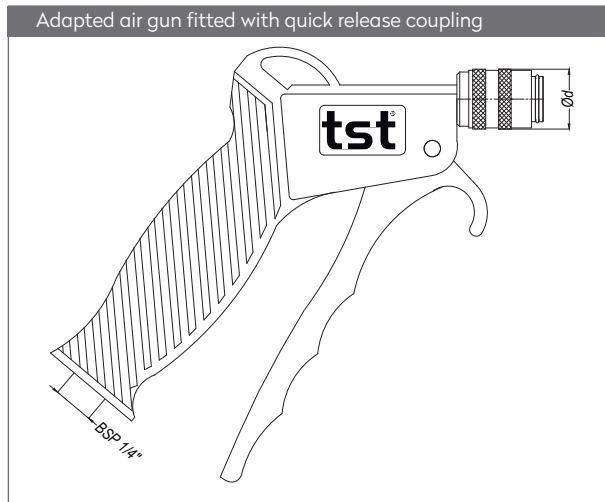

Part No.	Ød
TSW00 - 060	18

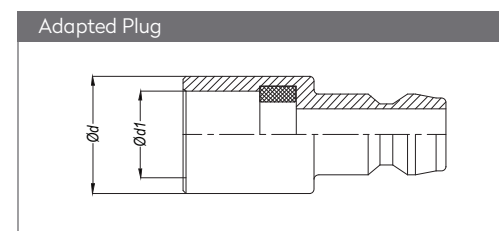

Part No.	Ød	Ød1	L
6 HTU 060	14	9.5	28.5
9 HTU 060	18	13.5	35



Materials

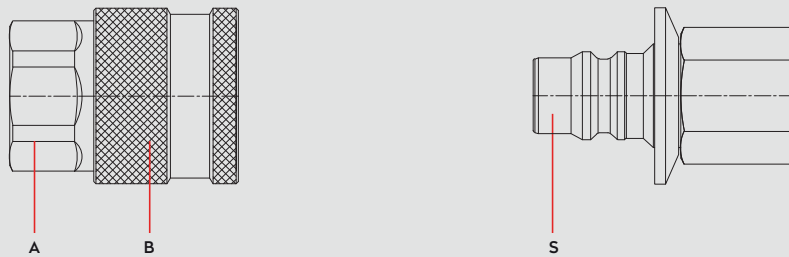

Material Code

- A = Hardened Steel - Zinc Plated
- B = Hardened Steel - Zinc Plated
- S = Hardened Steel - Zinc Plated



0 - 700 bar



-40°C to +105°C (NBR)

Shut Off Type



Applications

- Waterblast
- High Pressure
- Wireline - Grease Injection
- Water Jetting

Compatible with

DIXON EA
PARKER WB
AERO QUIP FD69
SNAP - TITE 56 SERIES

DN	12 mm
FLOW	180 lt/min

QUICK COUPLINGS SCHNELLKUPPLUNGEN

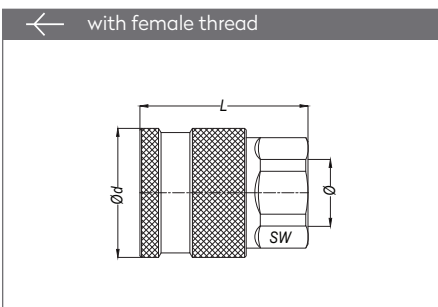

Part No.	Ø	SW	L	Ød
047 DGF 17	BSP 3/8"	32	52.7	40.5
047 DGF 21	BSP 1/2"	32	52.7	40.5
047 NGF 17	NPTF 3/8"-18	32	52.7	40.5
047 NGF 21	NPTF 1/2"-14	32	52.7	40.5

PLUGS STECKNIPPEL

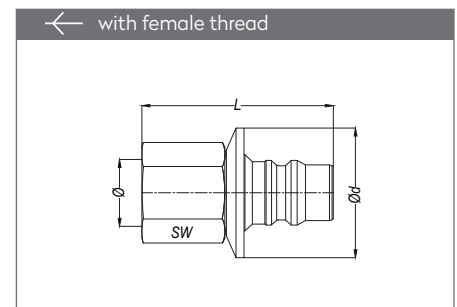

Part No.	Ø	SW	L	Ød
047 DU 17	BSP 3/8"	1-1/8	60	Ø40.7
047 DU 21	BSP 1/2"	1-1/8	60	Ø40.7
047 NU 17	NPTF 3/8"-18	1-1/8	60	Ø40.7
047 NU 21	NPTF 1/2"-14	1-1/8	60	Ø40.7

MOULD COOLING COUPLINGS
KÜHLUNGSELEMENTE FÜR WERKZEUGE

SERIE 059-060-090-190



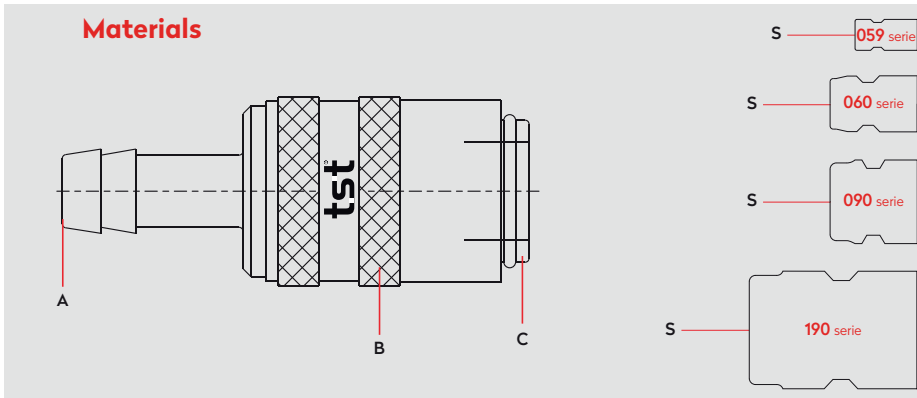

Material Code

A = Brass
B = Brass
C = Brass
S = Brass

(059 serie is Nickel Plated)

0 - 25 bar

-26°C to + 200°C (FPM)

Shut Off Type

TST 059 → OV100-00500 / OV100-00300
TST 060 → OV250-00800
TST 090 → OV262-01235
TST 190 → OV262-01785 / OV262-01235

European Serie

DN

TST 059 → 2.7 mm
TST 060 → 6 mm
TST 090 → 9 mm
TST 190 → 13 mm

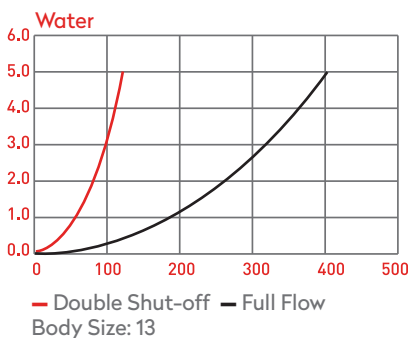
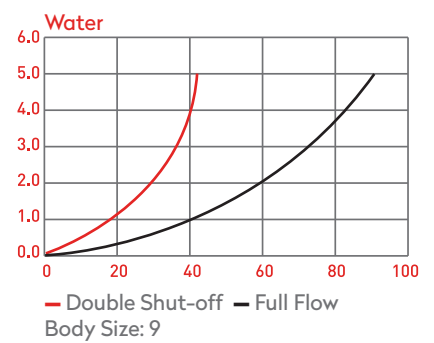
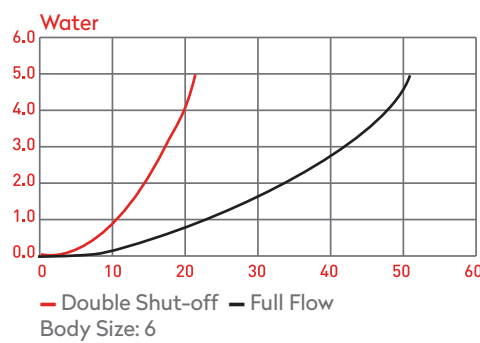
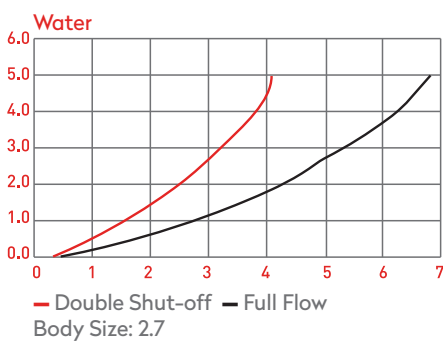

Options

- E1
- E2
- E3
- Id. Ring
- NICKEL
- HT
- AISI303
Stainless Steel
- NPT

Compatible with

HASCO
DYROS
EOC
LÜDECKE ESHMC 059,
ESHM 060, ESH 090, ESHG 190
ESHME 060-S3, ESHE 090-S3

MOULD COOLING COUPLINGS

KÜHLUNGSELEMENTE FÜR WERKZEUGE



SERIE 059-060-090-190

QUICK COUPLINGS SCHNELLKUPPLUNGEN

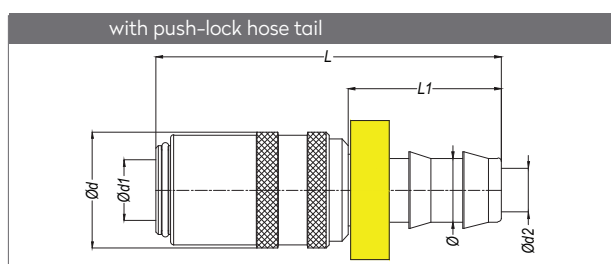
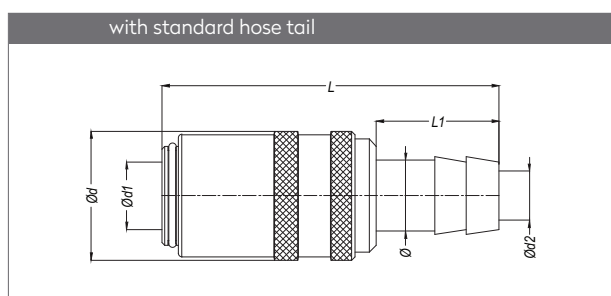
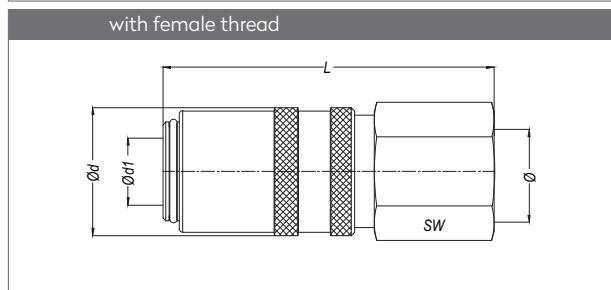
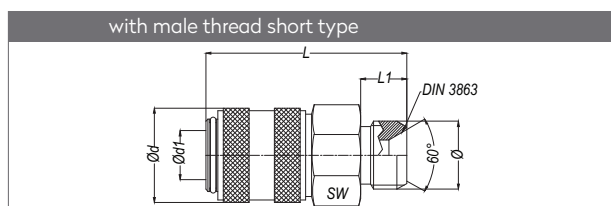
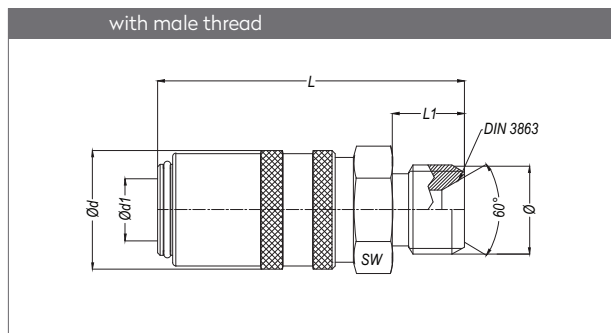

↻ / With Valve	← / Without Valve	DN	Ø	Ød	Ød1	L	L1	SW
CSK 060-EG 10	SK 060-EG 10	6	BSP 1/8"	18.2	9	44	8	17
CSK 060-EGM 10	SK 060-EGM 10	6	M10x1.0	18.2	9	44.5	11	17
CSK 060-EG 13	SK 060-EG 13	6	BSP 1/4"	18.2	9	47	11	17
CSK 060-EGM 14	SK 060-EGM 14	6	M14x1.5	18.2	9	47	11	17
CSK 060-EGM 16	SK 060-EGM 16	6	M16x1.5	18.2	9	47	11	17
CSK 060-EG 17	SK 060-EG 17	6	BSP 3/8"	18.2	9	47	11	17
CSK 090-EG 13	SK 090-EG 13	9	BSP 1/4"	23	13.6	51.3	11	21
CSK 090-EGM 16	SK 090-EGM 16	9	M16x1.5	23	13.5	51.3	11	21
CSK 090-EG 17	SK 090-EG 17	9	BSP 3/8"	23	13.5	51.3	11	21
CSK 090-EGM 18	SK 090-EGM 18	9	M18x1.5	23	13.5	51.3	11	21
CSK 090-EG 21	SK 090-EG 21	9	BSP 1/2"	23	13.5	51.3	14	21
CSK 190-EG 21	SK190-EG21	13	BSP 1/2"	32	19.6	75	14	30
CSK 190-EGM 24	SK 190-EGM 24	13	M24x1.5	32	19	77	16	30
CSK 190-EG 26	SK 190-EG 26	13	BSP 3/4"	32	19	77	16	30

Part no. / With Valve	DN	Ø	Ød	Ød1	L	L1	SW
060 EG 13	6	BSP 1/4"	18.2	9	39	9	17
090 EG 17	9	BSP 3/8"	23	13.6	38	9	21

↻ / With Valve	← / Without Valve	DN	Ø	Ød	Ød1	L	L1	SW
CSK 060-DGM 10	SK 060-DGM 10	6	M10x1.0	18.2	9	47	9	17
CSK 060-DG 13	SK 060-DG 13	6	BSP 1/4"	18.2	9	47	11	17
CSK 060-DGM 14	SK 060-DGM 14	6	M14x1.5	18.2	9	47	11	17
CSK 060-DG 17	SK 060-DG 17	6	BSP 3/8"	18.2	9	47	11	19
CSK 090-DGM 16	SK 090-DGM 16	9	M16x1.5	23.3	13.5	48	9	21
CSK 090-DG 17	SK 090-DG 17	9	BSP 3/8"	23.3	13.5	48	9	21
CSK 090-DG 21	SK 090-DG 21	9	BSP 1/2"	23.3	13.5	50.3	12	24
CSK 190-DG 21	SK 190-DG 21	13	BSP 1/2"	32	19	77	14	30
CSK 190-DGM 24	SK 190-DGM 24	13	M24x1.5	32	19	77	16	30
CSK 190-DG 26	SK190-DG26	13	BSP 3/4"	32	19	77	18	30

↻ / With Valve	← / Without Valve	DN	Ø	Ød	Ød1	Ød2	L	L1
CSK 059-05	SK 059-05	2.7	5-1/16"	10	5	2.7	35	13.5
CSK 060-06	SK 060-06	6	6-1/4"	18.2	9	4	47.5	17.3
CSK 060-08	SK 060-08	6	8-5/16"	18.2	9	6	47.5	17.3
CSK 060-09	SK 060-09	6	9-5/14"	18.2	9	7	47.5	17.3
CSK 060-10	SK 060-10	6	10-3/8"	18.2	9	8	47.5	17.3
CSK 060-13	SK 060-13	6	13-1/2"	18.2	9	9	53.5	23.3
CSK 090-10	SK 090-10	9	10-3/8"	23	13.5	8	59.1	23.3
CSK 090-11	SK 090-11	9	11	23	13.5	9	59.1	23.3
CSK 090-13	SK 090-13	9	13-1/2"	23	13.5	10	59.1	23.3
CSK 190-13	SK 190-13	13	13-1/2"	32	19	10	90	32
CSK 190-16	SK 190-16	13	16-5/8"	32	19	13	90	32
CSK 190-19	SK 190-19	13	19-3/4"	32	19	13	90	32

↻ / With Valve	← / Without Valve	DN	Ø	Ød	Ød1	Ød2	L	L1
CSK 060-FG 06	SK 060-FG 06	6	6.7-1/4"	18.2	9	4.5	54.2	24
CSK 060-FG 10	SK 060-FG 10	6	10-3/8"	18.2	9	7.5	54.2	24
CSK 060-FG 13	SK 060-FG 13	6	13-1/2"	18.2	9	10	58.2	28
CSK 090-FG 10	SK 090-FG 10	9	10-3/8"	23	13.5	7.5	60	28
CSK 090-FG 13	SK 090-FG 13	9	13-1/2"	23	13.5	10	64	28
CSK 190-FG 16	SK 190-FG 16	13	16-5/8"	32	19	13	97	38
CSK 190-FG 19	SK 190-FG 19	13	19-3/4"	32	19	15	97	38

MOULD COOLING COUPLINGS
KÜHLUNGSELEMENTE FÜR WERKZEUGE

SERIE 059-060-090-190



QUICK COUPLINGS SCHNELLKUPPLUNGEN

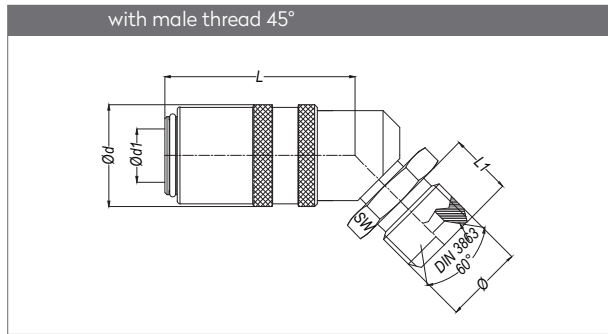

↻ / With Valve	← / Without Valve	DN	Ø	Ød	Ød1	L	L1	SW
CSK 060 EG 13-45°	SK 060 EG 13-45°	6	BSP 1/4"	18.2	9	34	11	14
CSK 060 EGM 14-45°	SK 060 EGM 14-45°	6	M14x1.5	18.2	9	34	11	17
CSK 060 EGM 16-45°	SK 060 EGM 16-45°	6	M16x1.5	18.2	9	34	11	17
CSK 060 EG 17-45°	SK 060 EG 17-45°	6	BSP 3/8"	18.2	9	34	11	17
CSK 090 EG 17-45°	SK 090 EG 17-45°	9	BSP 3/8"	23	13.5	52.3	11	17
CSK 090 EGM 16-45°	SK 090 EGM 16-45°	9	M16x1.5	23	13.5	52.3	11	17
CSK 090 EG 21-45°	SK 090 EG 21-45°	9	BSP 1/2"	23	13.5	52.3	11	21
CSK 190 EG 21-45°	SK 190 EG 21-45°	13	BSP 1/2"	32	19	75.5	16	22
CSK 190 EGM 24-45°	SK 190 EGM 24-45°	13	M24x1.5	32	19	75.5	16	24

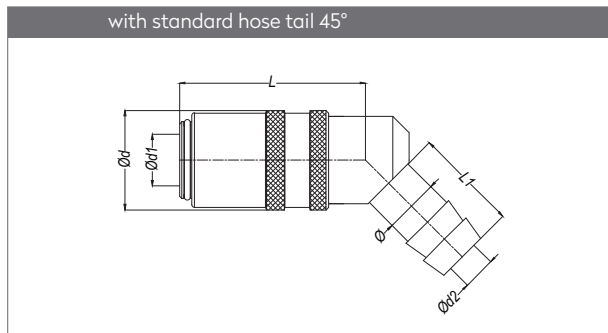

↻ / With Valve	← / Without Valve	DN	Ø	Ød	Ød1	Ød2	L	L1
CSK 059-05-45°	SK 059-05-45°	2.7	5-3/16"	11	5	3.5	29.5	15
CSK 060-06-45°	SK 060-06-45°	6	6.7-1/4"	18.2	9	4	42	18.5
CSK 060-08-45°	SK 060-08-45°	6	8-5/16"	18.2	9	6	42	18.5
CSK 060-09-45°	SK 060-09-45°	6	9-5/14"	18.2	9	6	31.4	18.5
CSK 060-10-45°	SK 060-10-45°	6	10-3/8"	18.2	9	6	34	20.5
CSK 060-13-45°	SK 060-13-45°	6	13-1/2"	18.2	9	9	34	23
CSK 090-10-45°	SK 090-10-45°	9	10-3/8"	23	13.5	8	52.3	24.5
CSK 090-13-45°	SK 090-13-45°	9	13-1/2"	23	13.5	10	35.9	26
CSK 190-19-45°	SK 190-19-45°	13	19-3/4"	32	19	13	75.5	34

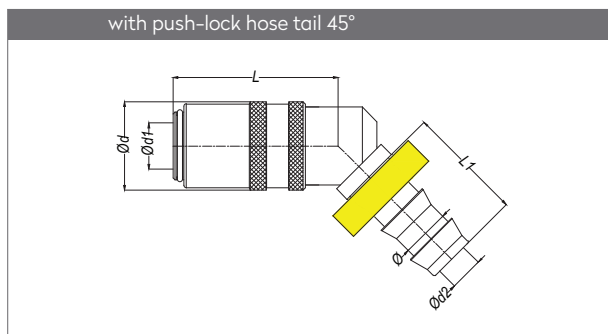

↻ / With Valve	← / Without Valve	DN	Ø	Ød	Ød1	Ød2	L	L1
CSK 060 FG 06-45°	SK 060 FG 06-45°	6	6.7-1/4"	18.2	9	4.5	34	24
CSK 060 FG 10-45°	SK 060 FG 10-45°	6	10-3/8"	18.2	9	7	34	24
CSK 060 FG 13-45°	SK 060 FG 13-45°	6	13-1/2"	18.2	9	10	34	28
CSK 090 FG 10-45°	SK 090 FG 10-45°	9	10-3/8"	23	13.5	7.5	52.3	24
CSK 090 FG 13-45°	SK 090 FG 13-45°	9	13-1/2"	23	13.5	10	52.3	28
CSK 190 FG 16-45°	SK 190 FG 16-45°	13	16-5/8"	32	19	13	75.5	38
CSK 190 FG 19-45°	SK 190 FG 19-45°	13	19-3/4"	32	19	13	75.5	38

MOULD COOLING COUPLINGS

KÜHLUNGSELEMENTE FÜR WERKZEUGE

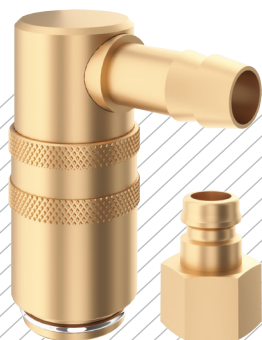

SERIE 059-060-090-190

QUICK COUPLINGS SCHNELLKUPPLUNGEN

with male thread 90°

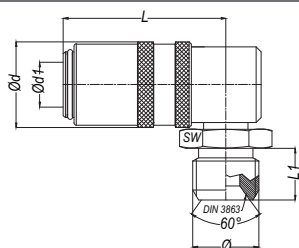

↻ With Valve	← Without Valve	DN	Ø	Ød	Ød1	L	L1	SW
CSK 060 EG 13-90°	SK 060 EG 13-90°	6	BSP 1/4"	18.2	9	34.5	11	14
CSK 060 EGM 14-90°	SK 060 EGM 14-90°	6	M14x1.5	18.2	9	34.5	11	17
CSK 060 EGM 16-90°	SK 060 EGM 16-90°	6	M16x1.5	18.2	9	34.5	11	17
CSK 060 EG 17-90°	SK 060 EG 17-90°	6	BSP 3/8"	18.2	9	34.5	11	17
CSK 090 EG 13-90°	SK 090 EG 13-90°	9	BSP 1/4"	23	13.5	44.3	11	14
CSK 090 EG 17-90°	SK 090 EG 17-90°	9	BSP 3/8"	23	13.5	44.3	11	17
CSK 090 EGM 16-90°	SK 090 EGM 16-90°	9	M16x1.5	23	13.5	44.3	11	17
CSK 090 EG 21-90°	SK 090 EG 21-90°	9	BSP 1/2"	23	13.5	44.3	11	21
CSK 190 EG 21-90°	SK 190 EG 21-90°	13	BSP 1/2"	32	19	65.5	16	22
CSK 190 EGM 24-90°	SK 190 EGM 24-90°	13	M24x1.5	32	19	65.5	16	24

with standard hose tail 90°

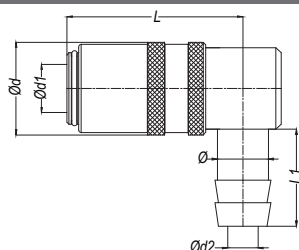

↻ With Valve	← Without Valve	DN	Ø	Ød	Ød1	Ød2	L	L1
CSK 059-05-90°	SK 059-05-90°	2.7	5-3/16"	11	5	3.5	29.5	15
CSK 060-06-90°	SK 060-06-90°	6	6-1/4"	18.2	9	4	34.5	18.5
CSK 060-08-90°	SK 060-08-90°	6	8-5/16"	18.2	9	6	34.5	18.5
CSK 060-09-90°	SK 060-09-90°	6	9-5/14"	18.2	9	6	34.5	20.5
CSK 060-10-90°	SK 060-10-90°	6	10-3/8"	18.2	9	6	34.5	20.5
CSK 060-13-90°	SK 060-13-90°	6	13-1/2"	18.2	9	9	34.5	23
CSK 090-10-90°	SK 090-10-90°	9	10-3/8"	23	13.5	8	44.3	24.5
CSK 090-13-90°	SK 090-13-90°	9	13-1/2"	23	13.5	10	43	26
CSK 190-13-90°	SK 190-13-90°	13	13-1/2"	32	19	10	65.5	33.3
CSK 190-19-90°	SK 190-19-90°	13	19-3/4"	32	19	13	65.5	34

with push-lock hose tail 90°

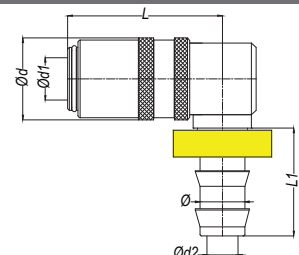

↻ With Valve	← Without Valve	DN	Ø	Ød	Ød1	Ød2	L	L1
CSK 060 FG 06-90°	SK 060 FG 06-90°	6	6.7-1/4"	18.2	9	4.5	34.5	24
CSK 060 FG 09-90°	SK 060 FG 09-90°	6	9-5/14"	18.2	9	7	34.5	24
CSK 060 FG 10-90°	SK 060 FG 10-90°	6	10-3/8"	18.2	9	7.5	34.5	24
CSK 090 FG 10-90°	SK 090 FG 10-90°	9	10-3/8"	23	13.5	7.5	44.3	24
CSK 090 FG 13-90°	SK 090 FG 13-90°	9	13-1/2"	23	13.5	10	44.3	28
CSK 190 FG 16-90°	SK 190 FG 16-90°	13	16-5/8"	32	19	13	65.5	38
CSK 190 FG 19-90°	SK 190 FG 19-90°	13	19-3/4"	32	19	15	65.5	38

MOULD COOLING COUPLINGS
KÜHLUNGSELEMENTE FÜR WERKZEUGE

SERIE 059-060-090-190



QUICK COUPLINGS SCHNELLKUPPLUNGEN

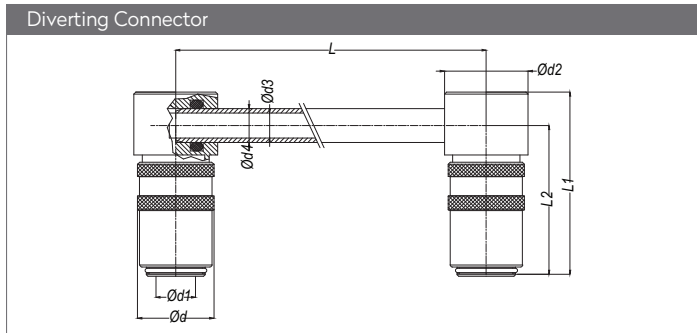

With Valve	Without Valve	Ød	Ød1	Ød2	Ød3	Ød4	L	L1	
CSK 060 KG 125	SK 060 KG 125	18.2	9	20	6	8	125	44	
CSK 060 KG 250	SK 060 KG 250	18.2	9	20	6	8	250	44	
CSK 060 KG 500	SK 060 KG 500	18.2	9	20	6	8	500	44	
CSK 090 KG 125	SK 090 KG 125	23	13.5	26	8	10	125	52.3	
CSK 090 KG 250	SK 090 KG 250	23	13.5	26	8	10	250	52.3	
CSK 090 KG 500	SK 090 KG 500	23	13.5	26	8	10	500	52.3	
CSK 190 KG 160	SK 190 KG 160	32	19	36	12	14	160	80	
CSK 190 KG 315	SK 190 KG 315	32	19	36	12	14	315	80	
CSK 190 KG 500	SK 190 KG 500	32	19	36	12	14	500	80	

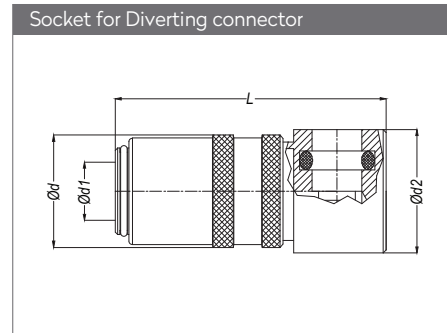

With Valve	Without Valve	Ød	Ød1	Ød2	L		
CSK 060 KG 00	SK 060 KG 00	18.2	9	20	44		
CSK 090 KG 00	SK 090 KG 00	23	13.5	26	52.3		
CSK 190 KG 00	SK 190 KG 00	32	19	36	80		

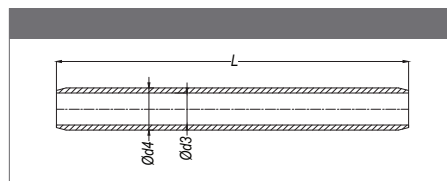

Part No. for the brass tube	Ød3	Ød4
060 KPB x Length	Ø 6	Ø 8
090 KPB x Length	Ø 8	Ø 10
190 KPB x Length	Ø 12	Ø 14

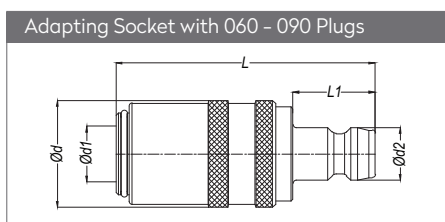

With Valve	Without Valve	DN	Ød	Ød1	Ød2	L	L1		
CSK 060 AU 090	SK 060 AU 090	6	18.2	9	13.5	46	32		
CSK 090 AU 060	SK 090 AU 060	9	23	13.5	9	50.3	36.3		

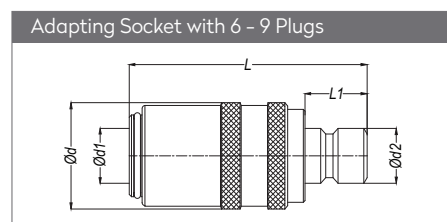

With Valve	Without Valve	DN	Ød	Ød1	Ød2	L	L1				
CSK 060 AU 06	SK 060 AU 06	6	18.2	9	9.4	42.6	32				
CSK 090 AU 09	SK 090 AU 09	9	23	13	13.5	50.3	36.3				

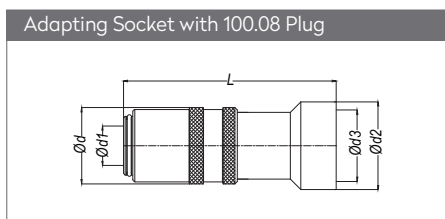

With Valve	Without Valve	DN	Ød	Ød1	Ød2	Ød3	L		
CSK 060 AU 100.08	SK 060 AU 100.08	6	18.2	9	21	17	58		
CSK 090 AU 100.08	SK 090 AU 100.08	9	23	13.5	21	17	58.3		

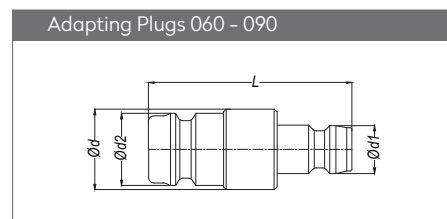

Part No.	Ød	Ød1	Ød2	L
060 HEF 00	15	9	13.5	38
060 HEF 060	11	9	9	34
090 HEF 00	14	13.5	13.5	40
190 HEF 090	20	13.5	19	54

MOULD COOLING COUPLINGS

KÜHLUNGSELEMENTE FÜR WERKZEUGE

SERIE 059-060-090-190



PLUGS STECKNIPPEL

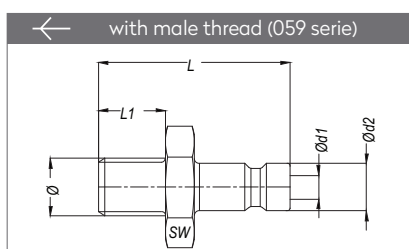

Part no.	Ø	Ød1	Ød2	SW	L	L1
059 EUM 5	M5	2.5	5	7	18	5
059 EUM 8	M8x0.75	2.5	5	11	21	8

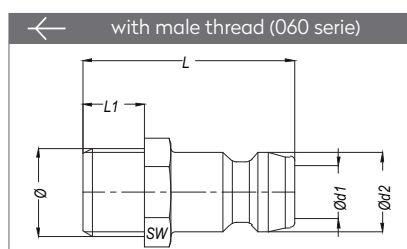

Part no.	Ø	Ød1	Ød2	SW	L	L1
060 EUM 8	M8x0.75	4.5	9	11	24	7
060 EUM 10	M10x1.0	6	9	11	24	7
060 EUM 10x1.5	M10x1.5	6	9	11	25	8
060 EU 10	BSP 1/8"	6	9	11	24	7
060 EUM 12	M12x1.5	6	9	14	26	9
060 EU 13	BSP 1/4"	6	9	14	26	9
060 EUM 14	M14x1.5	6	9	14	26	9
060 EUM 16	M16x1.5	6	9	17	26	9
060 EU 17	BSP 3/8"	6	9	17	26	9
060 EU 21	BSP 1/2"	6	9	21	29	12

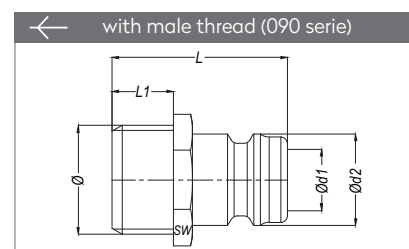

Part no.	Ø	Ød1	Ød2	SW	L	L1
090 EU 10	BSP 1/8"	9	13.5	14	23.8	7
090 EUM 10	M10x1.0	9	13.5	14	23.8	7
090 EUM 10x1.5	M10x1.5	9	13.5	14	25.8	9
090 EUM 12	M12x1.5	9	13.5	14	29.8	9
090 EU 13	BSP 1/4"	9	13.5	14	25.8	9
090 EUM 14	M14x1.5	9	13.5	15	25.8	9
090 EUM 16	M16x1.5	9	13.5	17	25.8	9
090 EU 17	BSP 3/8"	9	13.5	17	25.8	9
090 EU 21	BSP 1/2"	9	13.5	21	29.8	12
090 EU 26	BSP 3/4"	9	13.5	27	35	15

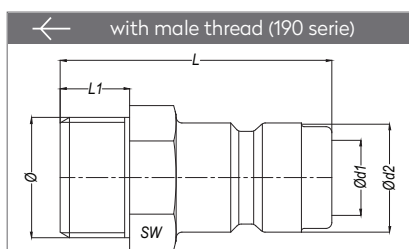

Part no.	Ø	Ød1	Ød2	SW	L	L1
190 EU 17	BSP 3/8"	11	19	21	10	42
190 EU 21	BSP 1/2"	13	19	22	12	47
190 EUM 24	M24x1.5	13	19	27	16	51
190 EU 26	BSP 3/4"	13	19	27	16	51

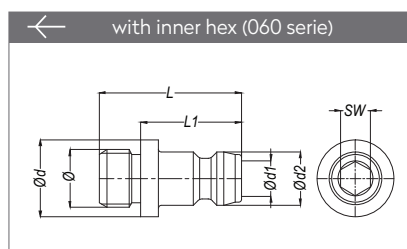

Part no.	Ø	Ød	SW	L	L1
060 AUM 10	M10x1.0	13	5	24	17
060 AUG 10	BSP 1/8"	13	5	24	17
060 AUG 13	BSP 1/4"	13.5	5	27	17

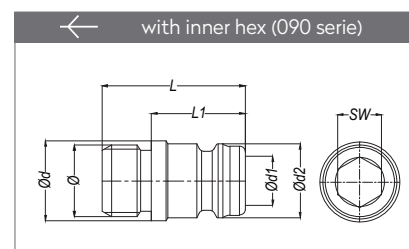

Part no.	Ø	Ød1	SW	L	L1
090 AUM 14	M14x1.5	14.5	5	26	17
090 AUG 13	BSP 1/4"	13.5	5	26	17
090 AUG 17	BSP 3/8"	17	5	26	17

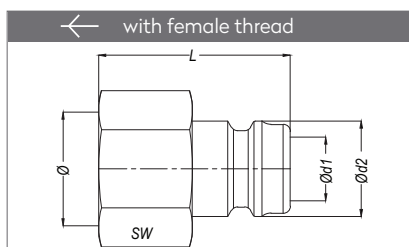

Part no.	Ø	Ød1	Ød2	SW	L
060 DUM 08	M8x1	6	9	13	22
060 DUM 10	M10x1	6	9	13	22
060 DU 10	BSP 1/8"	6	9	13	22
060 DU 13	BSP 1/4"	6	9	17	27
060 DU 17	BSP 3/8"	6	9	19	27.5
090 DU 10	BSP 1/8"	9	13.5	14	26
090 DU 13	BSP 1/4"	9	13.5	17	26
090 DU 17	BSP 3/8"	9	13.5	19	27
090 DU 21	BSP 1/2"	9	13.5	24	30
190 DU 17	BSP 3/8"	13	19	21	41.5
190 DU 21	BSP 1/2"	13	19	24	43.5
190 DU 26	BSP 3/4"	13	19	30	50

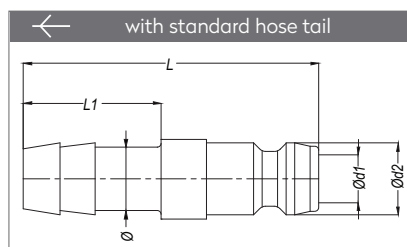

Part no.	DN	Ø	Ød1	Ød2	L	L1
059 HU 05	2.7	5	2.5	5	24	13
060 HU 06	6	6-1/4"	6	9	37	17.3
060 HU 08	6	8-5/16"	6	9	37	17.3
060 HU 09	6	9-5/14"	6	9	37	17.3
060 HU 10	6	10-3/8"	6	9	37	17.3
060 HU 13	6	13-1/2"	6	9	43	23.3
090 HU 10	9	10-3/8"	9	13.5	39	23.3
090 HU 13	9	13-1/2"	13	13.5	40	23.3
190 HU 13	13	13-1/2"	13	19	53	23.3
190 HU 19	13	19-3/4"	13	19	60	32

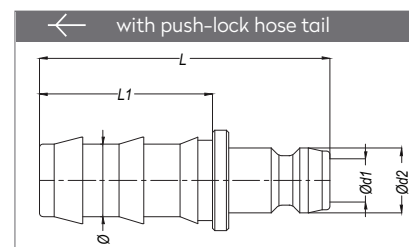

Part no.	DN	Ø	Ød1	Ød2	L	L1
060 FU 06	6	06-1/4"	6	9	44	24
060 FU 10	6	10-3/8"	6	9	44	24
060 FU 13	6	13-1/2"	6	9	45	28
090 FU 10	9	10-3/8"	9	13.5	43	24
090 FU 13	9	13-1/2"	9	13.5	47	28
190 FU 13	13	13-1/2"	Ø13	19	60	28
190 FU 19	13	19-3/4"	Ø13	19	70	38

MOULD COOLING COUPLINGS
KÜHLUNGSELEMENTE FÜR WERKZEUGE

SERIE 059-060-090-190



VALVED PLUGS VERSCHLUSSNIPPEL

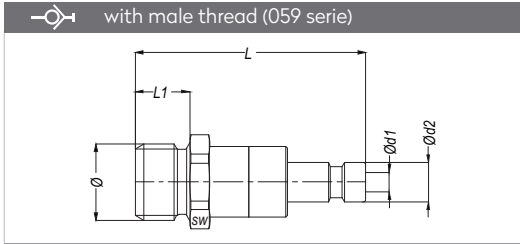

Part no.	Ø	Ød1	Ød2	SW	L	L1
059 EUBM 5	M5x0.8	2.8	5	9	28	5
059 EUBM 8	M8x0.75	2.8	5	9	30	7

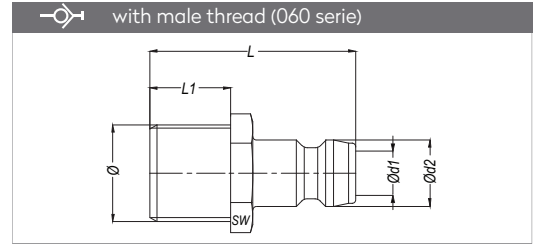

Part no.	Ø	Ød1	Ød2	SW	L	L1
060 EUB 13	BSP 1/4"	6	9	14	28	11
060 EUBM 14	M14x1.5	6	9	14	28	11
060 EUBM 16	M16x1.5	6	9	17	28	11
060 EUB 17	BSP 3/8"	6	9	17	28	11

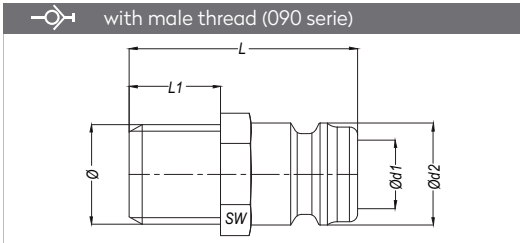

Part no.	Ø	Ød1	Ød2	SW	L	L1
090 EUB 13	BSP 1/4"	9	13.5	14	30	12
090 EUBM 14	M14x1.5	9	13.5	15	30	12
090 EUBM 16	M16x1.5	9	13.5	17	30	12
090 EUB 17	BSP 3/8"	9	13.5	17	30	12
090 EUB 21	BSP 1/2"	9	13.5	21	30	12

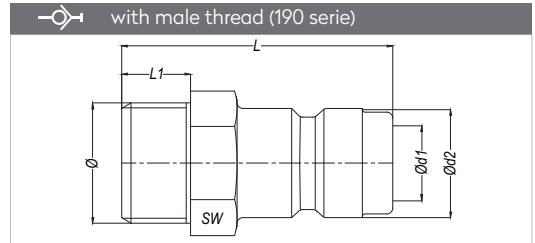

Part no.	Ø	Ød1	Ød2	SW	L	L1
190 EUB 21	BSP 1/2"	13	19	22	51	14.4
190 EUBM 24	M24x1.5	13	19	27	51	14.4
190 EUB 26	BSP 3/4"	13	19	27	51	14.4

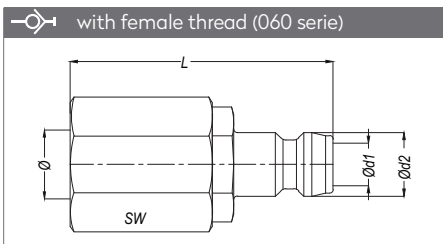

Part no.	Ø	Ød1	Ød2	SW	L
060 DUB 10	BSP 1/8"	6	9	17	37
060 DUB 13	BSP 1/4"	6	9	17	43

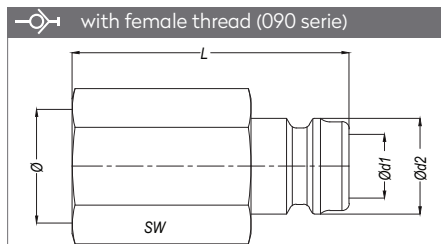

Part no.	Ø	Ød1	Ød2	SW	L
090 DUB 17	BSP 3/8"	9	13.5	19	39
090 DUB 21	BSP 1/2"	9	13.5	24	43

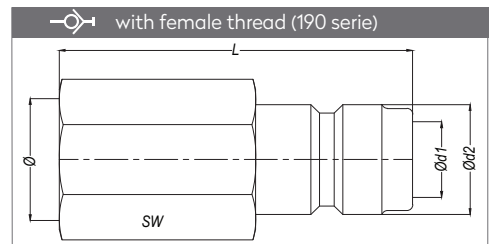

Part no.	Ø	Ød1	Ød2	SW	L
190 DUB 21	BSP 1/2"	13	19	24	60.8

MOULD COOLING COUPLINGS

KÜHLUNGSELEMENTE FÜR WERKZEUGE

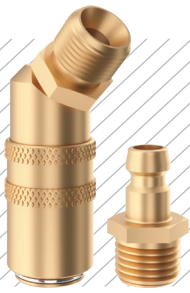

SERIE 059-060-090-190

PLUGS STECKNIPPEL

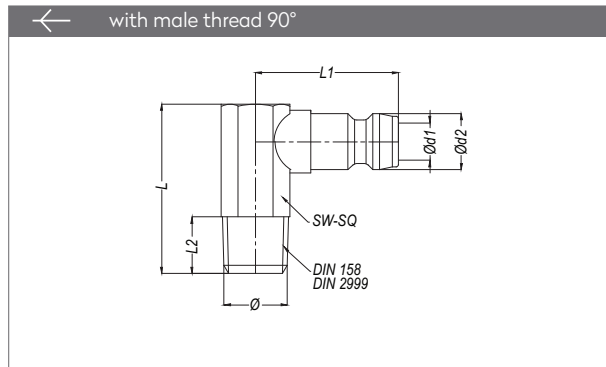

Part no.	Ø	Ød1	Ød2	SW	L	L1	L2
060 EUM 8-90°	M8x0.75	6	9	11	27	23	9
060 EUM 10-90°	M10x1.0	6	9	11	27	23	9
060 RU 10-90°	BSPT 1/8"	6	9	11	27	23	9
060 RU 13-90°	BSPT 1/4"	6	9	15	27	27.5	12
060 EUM 14-90°	M14x1.5	6	9	15	34	27.5	12
060 RU 17-90°	BSPT 3/8"	6	9	17	34	23	12
090 EUM 10x1-90°	M10x1	9	13.5	15	34	24.5	9
090 RU 13-90°	BSPT 1/4"	9	13.5	15	34	24.5	11
090 EUM 14-90°	M14x1.5	9	13.5	15	34	24.5	11
090 EUM 16-90°	M16x1.5	9	13.5	17	34	25	12
090 RU 17-90°	BSPT 3/8"	9	13.5	17	34	25	12
190 RU 21-90°	BSPT 1/2"	13	19	25	47	41.5	15
190 EUM 24-90°	M24x1.5	13	19	25	39	41.5	16

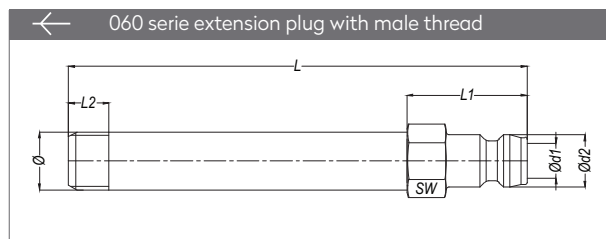

Part no.	Ø	Ød1	Ød2	SW	L1	L2	L60	L100	L150
060 EUM 8xL	M8x0.75	5	9	11	20.7	7	60	100	150
060 EUM 10xL	M10x1.0	6	9	11	20.7	7	60	100	150
060 EUM 10x1.5xL	M10x1.5	6	9	11	20.7	9	60	100	150
060 EU 10xL	BSP 1/8"	6	9	11	20.7	7	60	100	150
060 EUM 12x1.75xL	M12x1.75	6	9	14	21.8	10	60	100	150
060 EU 13xL	BSP 1/4"	6	9	14	20.7	9	60	100	150
060 EUM 14xL	M14x1.5	6	9	15	20.7	10	60	100	150
060 EU 17xL	BSP 3/8"	6	9	17	20.7	9	60	100	150

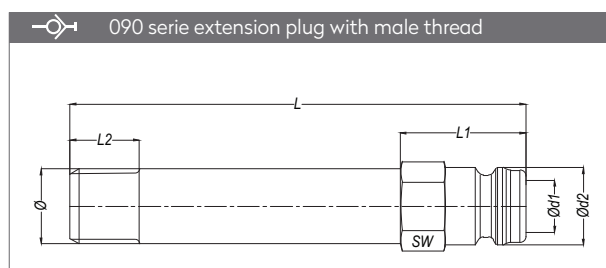

Part no.	Ø	Ød1	Ød2	SW	L1	L2	L60	L100	L150	L200	L250
090 EU 10xL	BSP 1/8"	9	13.5	14	21.8	7	60	100	150	200	250
090 EUM 10xL	M10x1.0	9	13.5	14	21.8	8	60	100	150	200	250
090 EUM 10x1.5xL	M10x1.5	9	13.5	14	21.8	10	60	100	150	200	250
090 EUM 12xL	M12x1.5	9	13.5	14	21.8	10	60	100	150	200	250
090 EU 13xL	BSP 1/4"	9	13.5	14	21.8	9	60	100	150	200	250
090 EUM 14xL	M14x1.5	9	13.5	15	21.8	10	60	100	150	200	250
090 EUM 16xL	M16x1.5	9	13.5	17	21.8	13	60	100	150	200	250
090 EU 17xL	BSP 3/8"	9	13.5	17	21.8	9	60	100	150	200	250
090 EU 21xL	BSP 1/2"	9	13.5	21	21.8	12	60	100	150	200	250

MOULD COOLING COUPLINGS
KÜHLUNGSELEMENTE FÜR WERKZEUGE



SERIE 059-060-090-190

PLUGS STECKNIPPEL

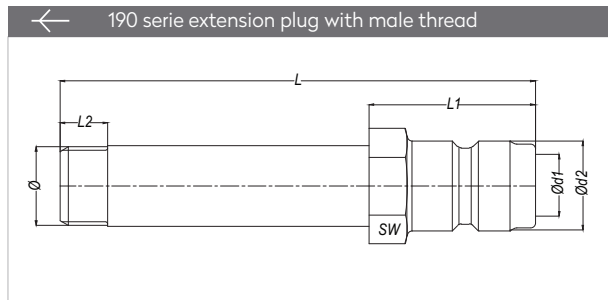

Part no.	Ø	Ød1	Ød2	SW	L1	L2	L60	L100	L150
190 EU 17xL	BSP 3/8"	13	19	21	35	12	250	500	800
190 EU 21xL	BSP 1/2"	13	19	22	35	15	250	500	800

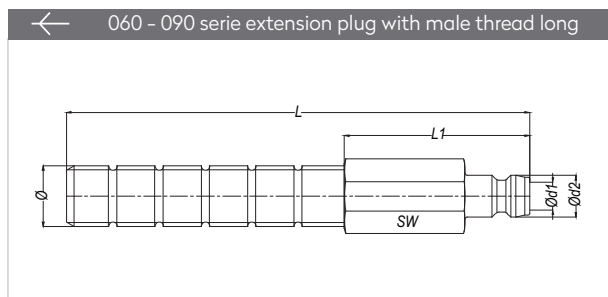

Part no.	Type	Ø	Ød1	Ød2	L	L1	SW
060 BLM 8x100	060	M8x0.75	6	9	100	40	11
060 BLM 10x100	060	M10x1.0	6	9	100	40	11
060 BL 10x100	060	BSP 1/8"	6	9	100	40	11
060 BL 13x100	060	BSP 1/4"	6	9	100	40	14
060 BLM 14x100	060	M14x1.5	6	9	100	40	14
060 BL 17x100	060	BSP 3/8"	6	9	100	40	17
090 BLM 10x100	090	M10x1.0	9	13.5	100	40	11
090 BL 10x100	090	BSP 1/8"	9	13.5	100	40	11
090 BL 13x100	090	BSP 1/4"	9	13.5	100	40	14
090 BLM 14x100	090	M14x1.5	9	13.5	100	40	14
090 BLM 16x100	090	M16x1.5	9	13.5	100	40	17
090 BL 17x100	090	BSP 3/8"	9	13.5	100	40	17

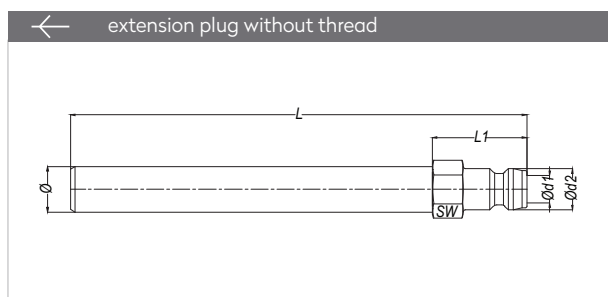

Part no.	Type	Ø	Ød1	Ød2	L	L1	SW
060 BU 63	060	8	6	9	63	20.7	9
060 BU 8x100	060	8	6	9	100	20.7	9
060 BU 100	060	10	6	9	100	20.7	11
060 BU 120	060	10	6	9	120	20.7	11
060 BU 240	060	10	6	9	240	20.7	11
060 BU 360	060	10	6	9	360	20.7	11
090 BU 150	090	14	9	13.5	150	21.8	15
090 BU 300	090	14	9	13.5	300	21.8	15
090 BU 450	090	14	9	13.5	450	21.8	15
190 BU 500	190	21	13	19	500	35	22
190 BU 800	190	21	13	19	800	35	22

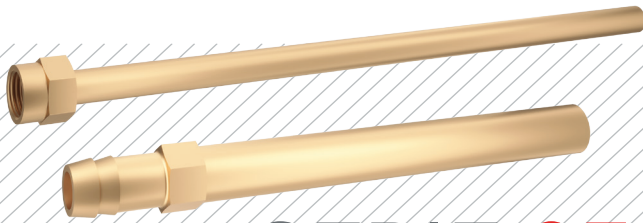

 MOULD COOLING COUPLINGS
 KÜHLUNGSELEMENTE FÜR WERKZEUGE

SERIE 059-060-090-190

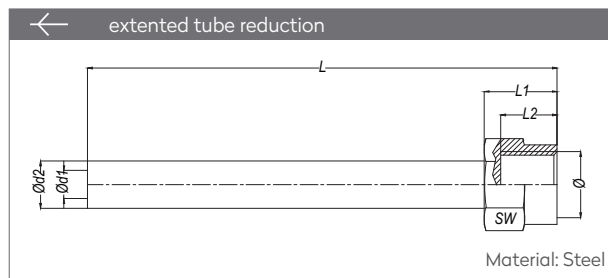
ACCESSORIES ZUBEHÖR

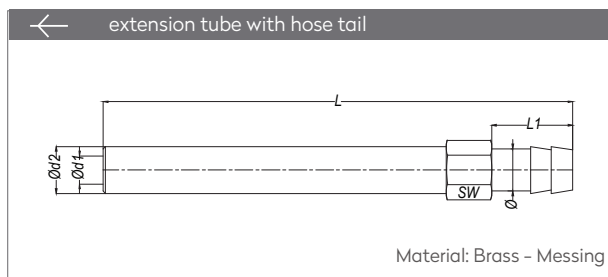

Part no.	Ø	Ød2	Ød1	L	L1	L2	SW
UNM 14 x 120	M14x1.5	10	6	120	15.5	12	17
UNM 14 x 240	M14x1.5	10	6	240	15.5	12	17
UNM 16 x 150	M16x1.5	14	9	150	15.5	12	22
UNM 16 x 300	M16x1.5	14	9	300	15.5	12	22



Part no.	Ø	Ød1	Ød2	L	L1	SW
BHE 120	9	6	10	120	17.3	11
BHE 240	9	6	10	240	17.3	11
BHE 360	9	6	10	360	17.3	11
BHE 150	13.3	9	14	150	23.3	15
BHE 300	13.3	9	14	300	23.3	15
BHE 450	13.3	9	14	450	23.3	15
BHE 500	19.3	13	21	500	27.3	22

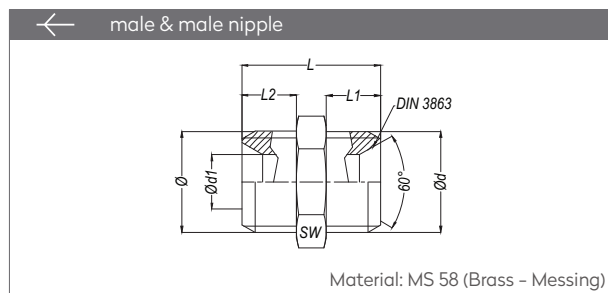

Part no.	Ø	Ød	Ød1	L	L1	L2	SW
DP 13 - M10	BSP 1/4"	M10x1	6	22	7	9	17
DP 13 - 13	BSP 1/4"	BSP 1/4"	6	23	9	9	17
DP 14 - 13	M14x1.5	BSP 1/4"	6	23	9	9	17
DP 14 - 14	M14x1.5	M14x1.5	6	23	9	9	17
DP 16 - 14	M16x1.5	M14x1.5	6	23	9	9	19
DP 16 - 16	M16x1.5	M16x1.5	9	23	9	9	19
DP 16 - 17	M16x1.5	BSP 3/8"	9	23	9	9	19
DP 17 - 17	BSP 3/8"	BSP 3/8"	9	23	9	9	19
DP 21 - 14	BSP 1/2"	M14x1.5	6	27	9	12	22
DP 21 - 16	BSP 1/2"	M16x1.5	9	27	9	12	22
DP 21 - 21	BSP 1/2"	BSP 1/2"	13	30	12	12	22
DP 24 - 21	M24x1.5	BSP 1/2"	13	36	12	16	27
DP 24 - 24	M24x1.5	M24x1.5	13	40	16	16	27
DP 26 - 26	BSP 3/4"	BSP 3/4"	13	40	16	16	27

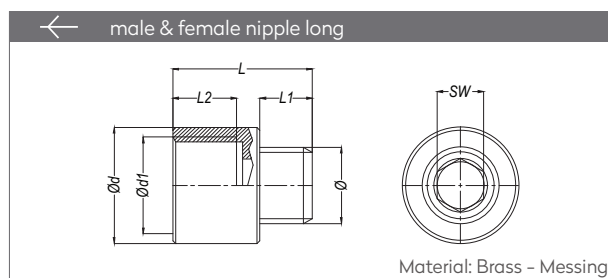

Part no.	Ø	Ød	Ød1	L	L1	L2	SW
BDM 14/10	M14x1.5	17	M10x1	22	6	12	6
BDM 13/10	BSP 1/4"	17	BSP 1/8"	22	6	12	6
BDM 16/14	M16x1.5	20	M14x1.5	24	9	12	8
BDM 17/13	BSP 3/8"	20	BSP 1/4"	24	9	12	8

MOULD COOLING COUPLINGS
KÜHLUNGSELEMENTE FÜR WERKZEUGE

SERIE 059-060-090-190

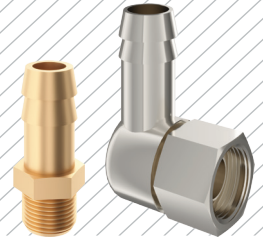

ACCESSORIES ZUBEHÖR

← with male & female thread short

Material: MS 58 (Brass - Messing)

Part no.	Ø	Ød1	L	L1	SW
RD 13/10	BSP 1/4"	BSP 1/8"	14	9	14
RD 14/10	M14x1.5	BSP 1/8"	14	9	15
RD 14/10-1	M14x1.5	M10x1.0	14	9	15
RD 17/13	BSP 3/8"	BSP 1/4"	13	9	19
RD 18/14	M18x1.5	M14x1.5	14	9	19
RD 21/17	BSP 1/2"	BSP 3/8"	18	12	22
RD 24/16	M24x1.5	M16x1.5	24	16	25
RD 26/21	BSP 3/4"	BSP 1/2"	24	16	27

← with hose tail with male thread short

Material: MS 58 (Brass - Messing)

Part no.	Ø	Ød1	Ød2	L	L1	SW
SHE M8	M8x0.75	9	6	27	6	11
SHE M10	M10x1.0	9	6	28	7	11
SHE 10	BSP 1/8"	9	6	28	7	11
SHE M12	M12x1.5	13	10	38	10	15
SHE 13	BSP 1/4"	13	8.5	37	9	14
SHE M14	M14x1.5	13	9	38	10	15
SHE M16	M16x1.5	13	10	38	10	17
SHE 17	BSP 3/8"	13	10	37	9	17
SHE M24	M24x1.5	19	16	48	16	25
SHE 21	BSP 1/2"	19	16	46	12	22
SHE 26	BSP 3/4"	19	16	49	16	27

← hose tail with male thread 90°

Material: Brass - Laiton

Part no.	Ø	Ød1	Ød2	L	L1	L2	SW
AHE M8	M8x0.75	9	6	27	9	24.1	11
AHE M10	M10x1	9	6	27	9	24.1	11
AHE 10	BSPT 1/8"	9	6	27	9	24.1	11
AHE M14	M14x1.5	13	9	34	12	33	15
AHE 13	BSPT 1/4"	13	9	34	12	33	15
AHE 17	BSPT 3/8"	13	9	34	12	33	17
AHE M24	M24x1.4	19	13	47	16	44.3	24
AHE 21	BSPT 1/2"	19	13	47	16	51.5	30

← with female thread

Material: Brass - Messing

Part no.	Ø	Ød1	Ød2	L	L1	SW
SN 14	M14x1.5	9	6	31.3	17.3	17
SN 13	BSP 1/4"	9	6	31.3	17.3	17
SN 16	M16x1.5	13	9	37.3	23.3	19
SN 17	BSP 3/8"	13	9	37.3	23.3	19
SN 24	M24x1.5	19	15	52	32	30
SN 26	BSP 3/4"	19	15	56	32	30

← with female thread 45°

Part no.	Ø	Ød1	Ød2	L	L1	L2	SW
SN 14-45	M14x1.5	9	6	26	21.7	26	17
SN 13-45	BSP 1/4"	9	6	26	21.7	26	17
SN 16-45	M16x1.5	13	9	30	26	30	19
SN 17-45	BSP 3/8"	13	9	30	26	30	19

← with female thread 90°

Part no.	Ø	Ød1	Ød2	L	L1	L2	SW
SN 14-90	M14x1.5	9	6	30.5	21.7	22.5	17
SN 13-90	BSP 1/4"	9	6	30.5	21.7	22.5	17
SN 16-90	M16x1.5	13	9	36.5	25	26	19
SN 17-90	BSP 3/8"	13	9	36.5	25	26	19

← with hose tail with male thread long

Material: MS 58 (Brass - Messing)

Part no.	Ø	Ød	Ød1	L	L1	L2
UHE M10	M10x1.0	9	6	40.5	7	14
UHE 10	BSP 1/8"	9	6	40.5	7	14
UHE M12	M12x1.5	13	8	47	9	16
UHE M14	M14x1.5	13	9	47	9	20
UHE 13	BSP 1/4"	13	9	47	9	20
UHE M24	M24x1.5	19	13	62	12	22
UHE 21	BSP 1/2"	19.5	13	62	12	22

MOULD COOLING COUPLINGS

KÜHLUNGSELEMENTE FÜR WERKZEUGE



SERIE 059-060-090-190

ACCESSORIES ZUBEHÖR

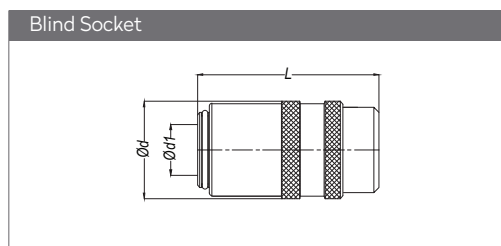

Part No.	DN	Ød	Ød1	L
059 KTG 00	2.7	11	5	23
060 KTG 00	6	17.3	9	34
090 KTG 00	9	23.2	13.5	39.8
190 KTG 00	13	32	19	59

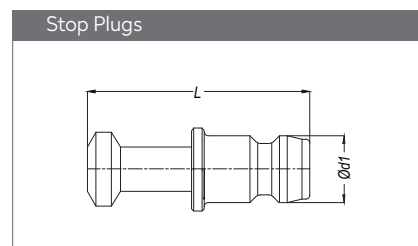

Part No.	Ød1
059 KTU 00	5
060 KTU 00	9
090 KTU 00	13
190 KTU 00	19

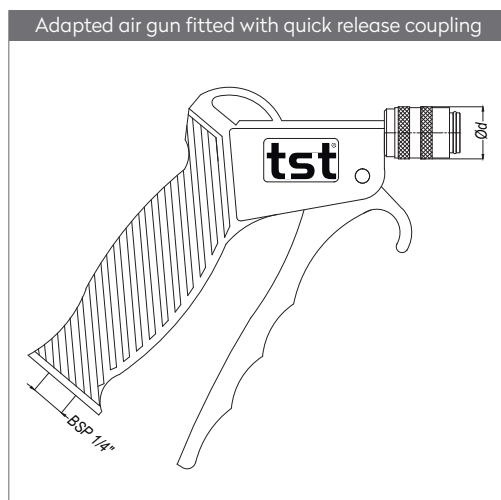

Part No.	d3
TSW00 - 060	18.2

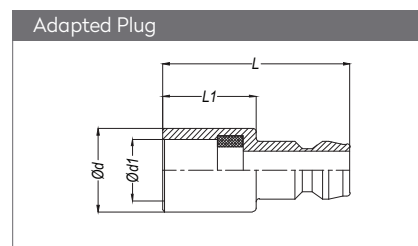

Part No.	Ød1	Ød	L	L1
006 HTU 060	9.5	14	28.5	14.3
009 HTU 090	13.6	18	35	20.8

SERIE 070

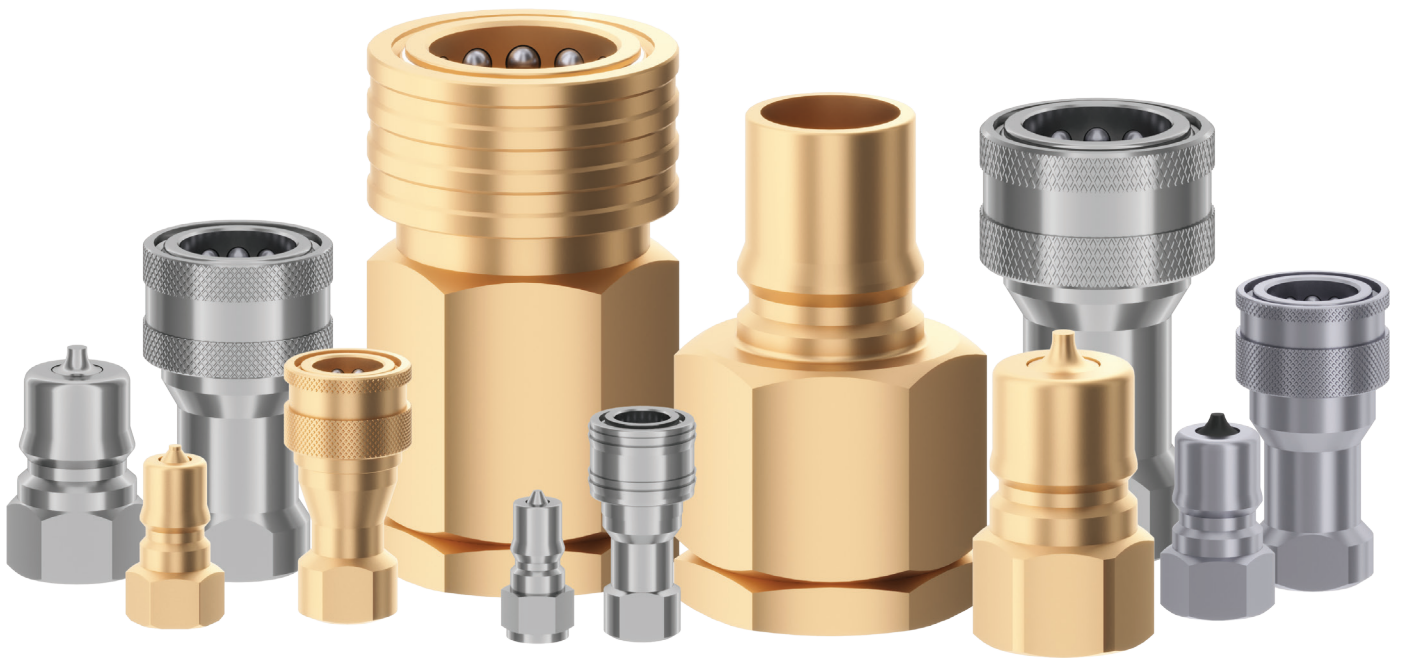



DN 4-19

SERIE 070

 WATER COUPLINGS
 WASSERKUPPLUNGEN

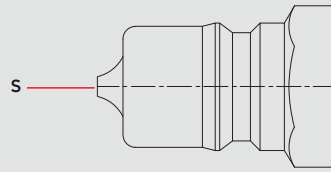
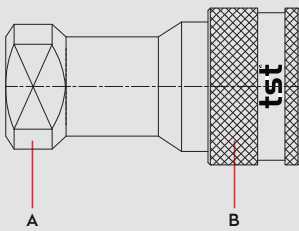
Materials

Material Code

A = Brass

B = Brass

S = Brass

DN	4 mm - 1/8"	6 mm - 1/4"	7.5 mm - 3/8"	11 mm - 1/2"	13 mm - 3/4"	19 mm - 1"
Brass	300 bar	200 bar	200 bar	180 bar	130 bar	130 bar
Steel	345 bar	520 bar	345 bar	345 bar	280 bar	280 bar
St. Steel	280 bar	380 bar	260 bar	260 bar	210 bar	210 bar
FLOW	10 lt/min	25 lt/min	50 lt/min	90 lt/min	220 lt/min	260 lt/min
COUPLING PLUS	OM 178-00290-90 OM 200-01100	OM 200-01400 07013VC-00M	OM 262-01870 07017VC-00M	OM 300-02300 07021VC-00M	OM 353-03134 07026VC-00M	OM 400-03700 07033VC-00M
	OM 178-00290-90	07013VC-00M	07017VC-00M	07021VC-00M	07026VC-00M	07033VC-00M

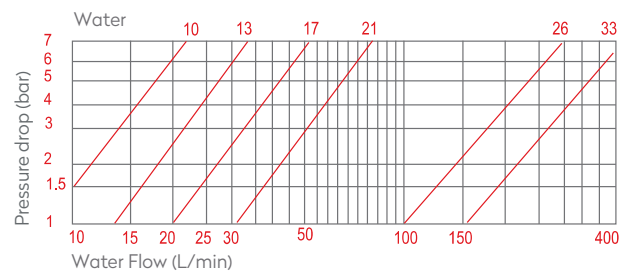
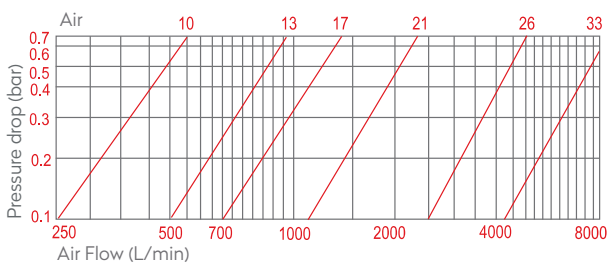

-40°C to + 105°C (NBR)

DN
4-19 mm
ISO 7241-1 SERIE B
Shut Off Type

Options
E1
STEEL
AISI316

Stainless Steel

FPM
NICKEL
EPDM
AISI303

Stainless Steel

VA
Applications
Compatible with

HANSEN

HK SERIE

PARKER

60 SERIE

RECTUS

70 SERIE

FASTER HNV SERIE ISO 7241-1 SERIE B

AISI 303, AISI 316Ti

SERIE 070

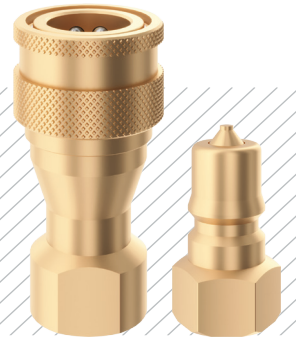

QUICK COUPLINGS SCHNELLKUPPLUNGEN

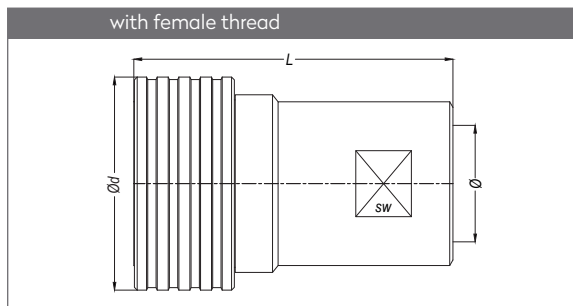
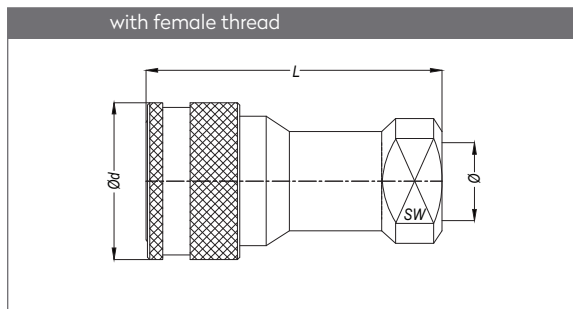

Double Shut-off	Full Flow	Ø	SW	Ød	L
070 DGB 10	070 DGF 10	BSP 1/8"	14	24	48
070 DGB 13	070 DGF 13	BSP 1/4"	19	28.2	55.3
070 DGB 17	070 DGF 17	BSP 3/8"	22	34	64
070 DGB 21	070 DGF 21	BSP 1/2"	28	42	71.5
070 DGB 26	070 DGF 26	BSP 3/4"	34	52	94
070 DGB 33	070 DGF 33	BSP 1"	41	60	106

Double Shut-off	DN	Ø	SW	Ød	L
063.25 DGB 42	25	BSP 1 1/4"	54	76.8	115
063.27 DGB 48 - P1	27	BSP 1 1/2"	58	86.8	138
063.30 DGB 48	30	BSP 1 1/2"	63	86	124

PLUGS STECKNIPPEL

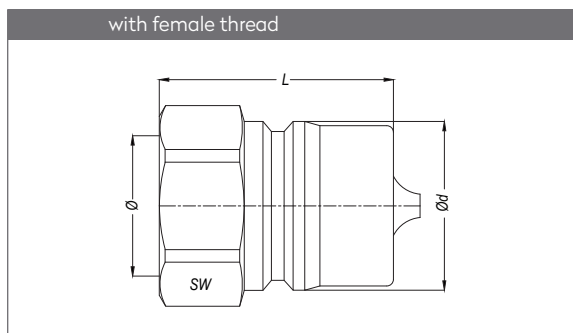
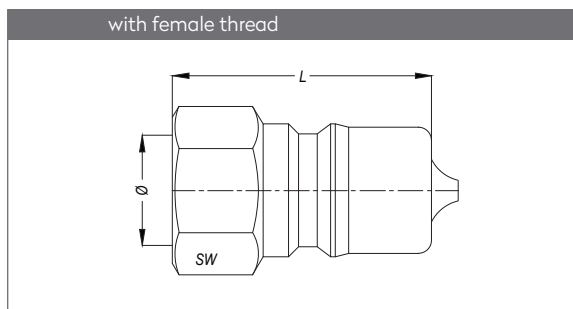

Double Shut-off	Full Flow	Ø	SW	L
070 DUB 10	070 DUF 10	BSP 1/8"	14	29.5
070 DUB 13	070 DUF 13	BSP 1/4"	19	35
070 DUB 17	070 DUF 17	BSP 3/8"	22	39
070 DUB 21	070 DUF 21	BSP 1/2"	27	44
070 DUB 26	070 DUF 26	BSP 3/4"	36	60
070 DUB 33	070 DUF 33	BSP 1"	41	65.5

Double Shut-off	DN	Ø	SW	Ød	L
063.25 DUB 42	25	BSP 1 1/4"	55	50.5	70
063.27 DUB 48 - P1	27	BSP 1 1/2"	58	56	80
063.30 DUB 48	30	BSP 1 1/2"	63	58.5	72

WATER COUPLINGS
WASSERKUPPLUNGEN

DN 32-50

SERIE 070

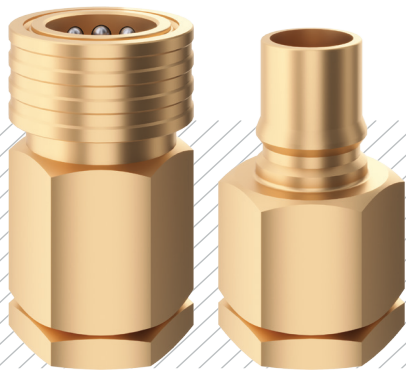

Materials

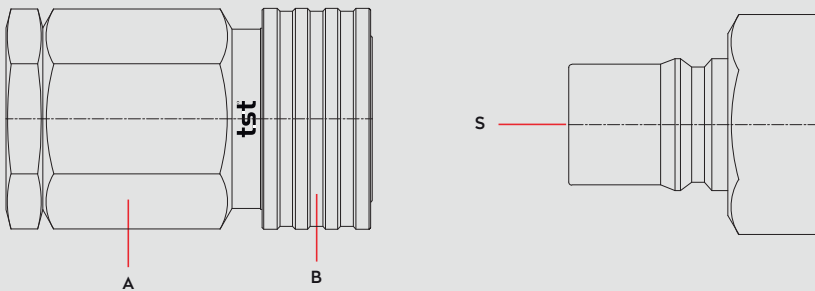

Material Code

A = Brass

B = Brass

S = Brass

DN	32 mm - 1 1/4"	38 mm - 1 1/2"	50 mm - 2"	50 mm - 2 1/2"	
Brass	60 bar	55 bar	50 bar	50 bar	
Steel	120 bar	150 bar	105 bar	105 bar	
St. Steel	120 bar	150 bar	105 bar	105 bar	
FLOW	760 lt/min	850 lt/min	1000 lt/min	1000 lt/min	
	COUPLING	TC-4500-3780-12 OM 262-02455 OM 262-04570 OM 400-03700	TC-5020-4450-13 OM 262-02900 OM 262-05365 OM 353-04405	TC-7220-6350-15 OM 353-07260 OM 534-06285 OM 400-04500	TC-7220-6350-15 OM 353-07260 OM 534-06285 OM 400-04500
	PLUG	OM 262-02455 OM 262-04570	OM 262-02900 OM 262-05365	OM 353-07260	OM 400-04500

Shut Off Type

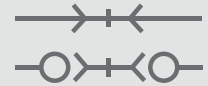

DN 32-50 mm



-40°C to + 105°C (NBR)

Options

E1	STEEL	AISI316 Stainless Steel	FPM
NICKEL	EPDM	AISI303 Stainless Steel	

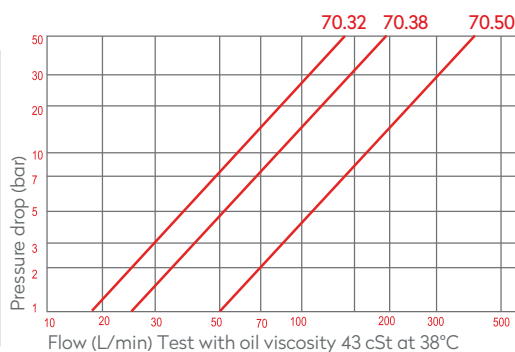

Compatible with

HANSEN
PARKER
RECTUS
FASTER

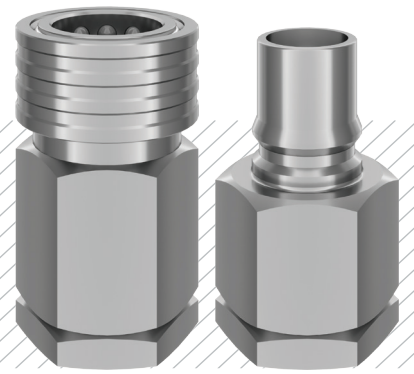

HK SERIE
60 SERIE
70 SERIE
HNV SERIE

SERIE 070



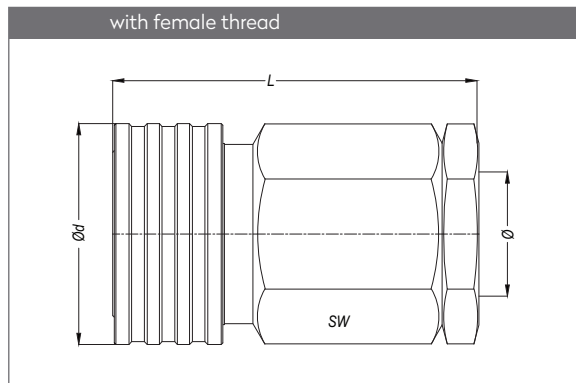

QUICK COUPLINGS SCHNELLKUPPLUNGEN

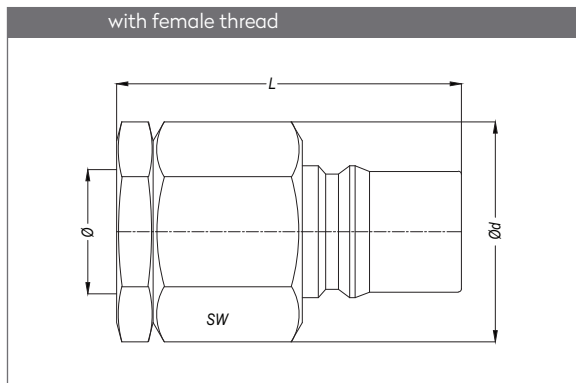

 Double Shut-off	 Full Flow	DN	Ø	SW	Ød	L
070.32 DGB 42	070.32 DGF 42	32	BSP 1 1/4"	60	69	114.8
070.38 DGB 48	070.38 DGF 48	38	BSP 1 1/2"	65	74.2	125
070.50 DGB 60	070.50 DGF 60	50	BSP 2"	90	105	142
070.50 DGB 75	070.50 DGF 75	50	BSP 2 1/2"	90	105	165.5

PLUGS STECKNIPPEL



 Double Shut-off	 Full Flow	DN	Ø	SW	Ød	L
070.32 DUB 42	070.32 DUF 42	32	BSP 1 1/4"	60	69	108.1
070.38 DUB 48	070.38 DUF 48	38	BSP 1 1/2"	65	69	125
070.50 DUB 60	070.50 DUF 60	50	BSP 2"	90	97	142
070.50 DUB 75	070.50 DUF 75	50	BSP 2 1/2"	90	97	165.5

WATER COUPLINGS
WASSERKUPPLUNGEN

DN 19-32

SERIE 071

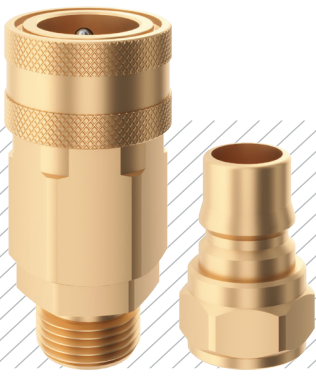

Materials

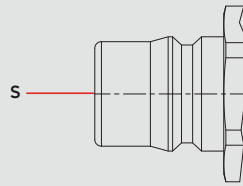
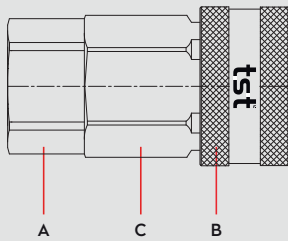

Material Code

A = Brass

B = Brass

C = Brass

S = Brass



0 - 35 bar



-40°C to + 105°C (NBR)

Shut Off Type



FLOW

7800 lt/min → 1/2" - 3/4"
9500 lt/min → 1" - 1 1/4"

DN

DN 19 → 1/2" - 3/4"
DN 32 → 1" - 1 1/4"

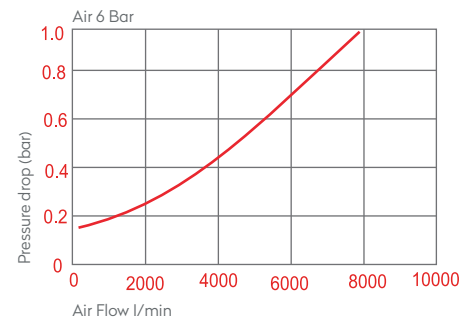
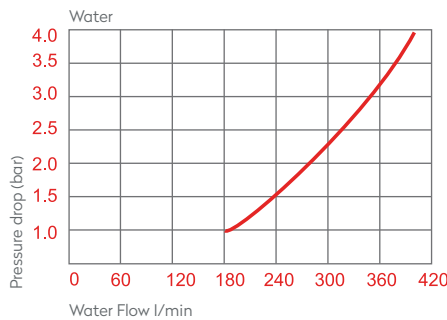
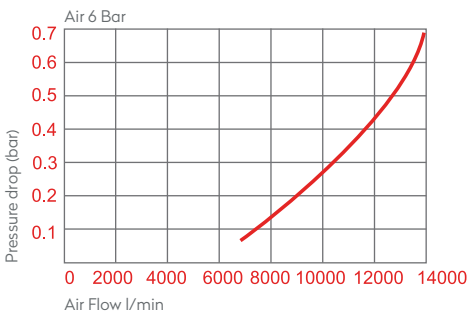

Options

FPM



NICKEL

AISI316
Stainless Steel

Applications

Compatible with

TST DESIGN

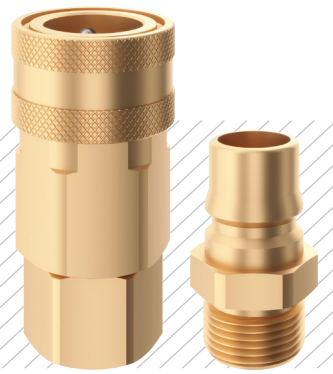

VALVED QUICK COUPLINGS SCHNELLKUPPLUNGEN MIT VENTIL

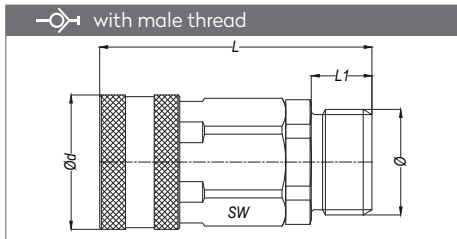

Part No.	Ø	SW	L	L1	Ød
071 EG 21	BSP 1/2"	36	80	14	42
071 EG 26	BSP 3/4"	36	82	16	42
071 EG 33	BSP 1"	36	85	19	42
071 EG 42	BSP 1 1/4"	36	85	19	42

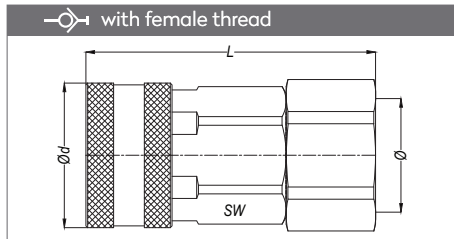

Part No.	Ø	SW	L	Ød
071 DG 21	BSP 1/2"	36	80	42
071 DG 26	BSP 3/4"	36	81	42
071 DG 33	BSP 1"	36	84	42
071 DG 42	BSP 1 1/4"	36	85	42

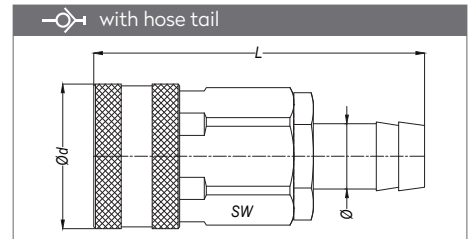

Part No.	Ø	SW	L	Ød
071 HG 16	16 mm-5/8"	36	96	42
071 HG 19	19 mm-3/4"	36	96	42
071 HG 25	25 mm-1"	36	96	42

UNVALVED QUICK COUPLINGS SCHNELLKUPPLUNGEN OHNE VENTIL

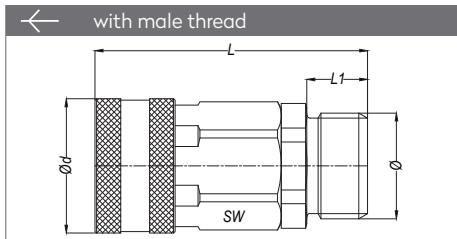

Part No.	Ø	SW	L	L1	Ød
071 EGF 21	BSP 1/2"	32	80	14	42
071 EGF 26	BSP 3/4"	32	82	16	42
071 EGF 33	BSP 1"	36	85	19	42
071 EGF 42	BSP 1 1/4"	46	85	19	42

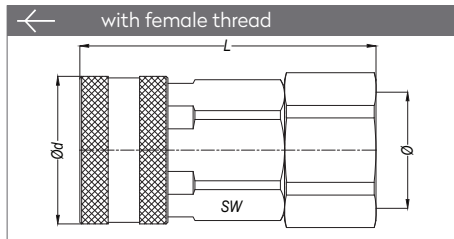

Part No.	Ø	SW	L	Ød
071 DGF 21	BSP 1/2"	36	80	42
071 DGF 26	BSP 3/4"	36	81	42
071 DGF 33	BSP 1"	36	84	42
071 DGF 42	BSP 1 1/4"	36	85	42

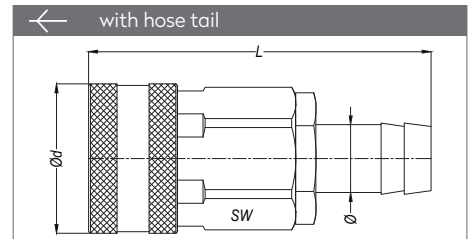

Part No.	Ø	SW	L	Ød
071 HGF 16	16 mm-5/8"	36	96	42
071 HGF 19	19 mm-3/4"	36	96	42
071 HGF 25	25 mm-1"	36	96	42

PLUGS STECKNIPPEL

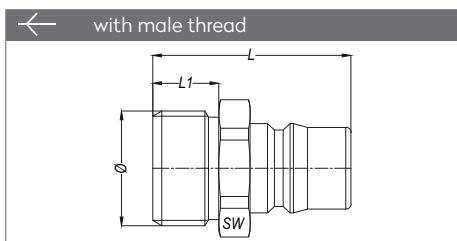

Part No.	Ø	SW	L	L1
071 EU 26	BSP 3/4"	30	54	16
071 EU 33	BSP 1"	36	57	19
071 EU 42	BSP 1 1/4"	45	60	22

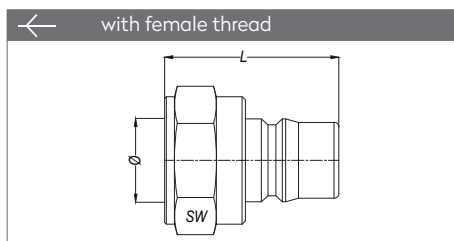

Part No.	Ø	SW	L
071 DU 26	BSP 3/4"	32	51
071 DU 33	BSP 1"	41	54
071 DU 42	BSP 1 1/4"	50	54

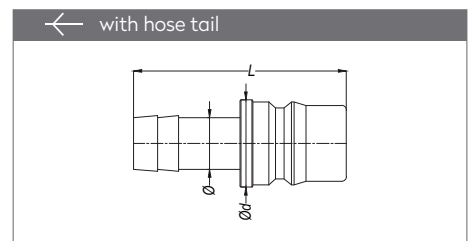

Part No.	Ø	L	Ød
071 HU 16	16 mm-5/8"	66	27
071 HU 19	19 mm-3/4"	66	27
071 HU 25	25 mm-1"	66	27



DN6-33

SERIE 072

HYDRAULIC COUPLINGS

HYDRAULISCHE KUPPLUNGEN

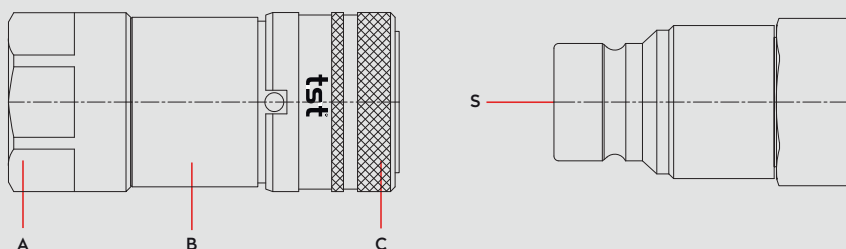
Materials

Material Code

A = Steel + Chrome Zinc Plated

B = Steel + Chrome Zinc Plated

C = Steel + Chrome Zinc Plated

S = Steel + Chrome Zinc Plated

FLOW

DN6 → 12 lt/min
 DN10 → 20 lt/min
 DN12 → 40 lt/min
 DN16 → 55 lt/min
 DN19 → 70 lt/min
 DN25 → 105 lt/min
 DN33 → 160 lt/min



-40° to + 105°C (NBR)

Shut Off Type

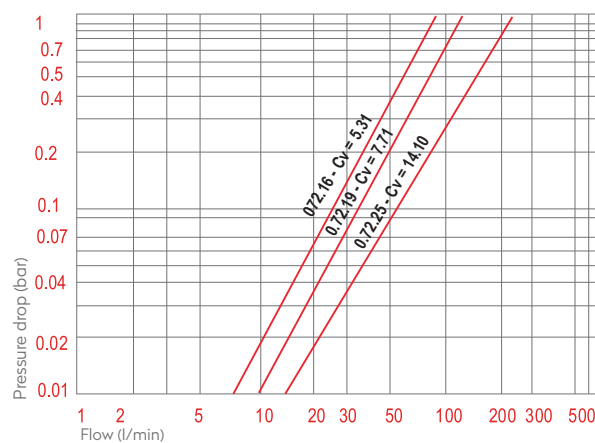
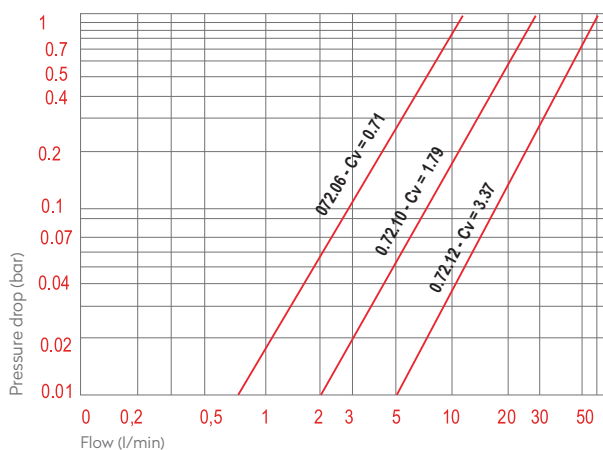
ISO 16028
FF
DN 6 - 33 mm

 Test oil viscosity : Oil - ISO VG32
 Viscosity: 28.8 - 35.2 mm²/s

 Temp. : 40°C
 Direction of flow: Socket to Plug

Options
FPM
AISI303
 Stainless Steel

Body Size	Max. Working Pres. Coupled	Burst Pres. Coupled	Burst Pres. Plug	Burst Pres. Socket
072.06	325 bar	1200 bar	1200 bar	700 bar
072.10	325 bar	1200 bar	1200 bar	700 bar
072.12	325 bar	1200 bar	1200 bar	700 bar
072.16	270 bar	1100 bar	1100 bar	700 bar
072.19	270 bar	950 bar	950 bar	500 bar
072.25	250 bar	950 bar	950 bar	500 bar
072.33	200 bar	700 bar	700 bar	400 bar

Compatible with

 STUCCHI
 TEMA

HYDRAULIC COUPLINGS
HYDRAULISCHE KUPPLUNGEN

SERIE 072



QUICK COUPLINGS SCHNELLKUPPLUNGEN

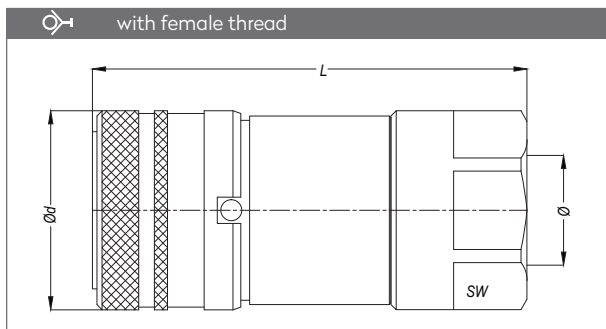

Part no.	DN	Ø	SW	L	Ød
072.06 DGB 13	1/4" 6 mm	BSP 1/4"	22	54.8	28
072.06 NGB 13	1/4" 6 mm	NPT 1/4"	22	54.8	28
072.06 UGB 14	1/4" 6 mm	UNF 9/16"-18	22	57.8	28
072.10 DGB 17	3/8" 10 mm	BSP 3/8"	27	65.2	32
072.10 DGB 21	3/8" 10 mm	BSP 1/2"	27	68.7	32
072.10 NGB 17	3/8" 10 mm	NPT 3/8"	27	65.2	32
072.10 NGB 21	3/8" 10 mm	NPT 1/2"	27	68.7	32
072.10 UGB 14	3/8" 10 mm	UNF 9/16"-18	27	66.4	32
072.10 UGB 19	3/8" 10 mm	UNF 3/4"-16	27	66.7	32
072.12 DGB 21	1/2" 12 mm	BSP 1/2"	35	83	38
072.12 NGB 21	1/2" 12 mm	NPT 1/2"	35	83	38
072.12 UGB 22	1/2" 12 mm	UNF 7/8"-14	35	83	38
072.12 DGB 26	1/2" 12 mm	BSP 3/4"	35	83	38
072.12 NGB 26	1/2" 12 mm	NPT 3/4"	35	83	38
072.12 UGB 27	1/2" 12 mm	UNF 11/16"-12	35	88	38
072.16 DGB 26	5/8" 16 mm	BSP 3/4"	36	85.5	42
072.16 NGB 26	5/8" 16 mm	NPT 3/4"	36	85.5	42
072.16 UGB 27	5/8" 16 mm	UNF 11/16"-12	36	85.5	42
072.19 DGB 33	3/4" 19 mm	BSP 1"	41	96.8	48
072.19 NGB 33	3/4" 19 mm	NPT 1"	41	96.8	48
072.19 UGB 33	3/4" 19 mm	UNF 15/16"-12	41	99.5	48
072.25 DGB 42	1" 25 mm	BSP 1 1/4"	55	110.3	55
072.25 NGB 42	1" 25 mm	NPT 1 1/4"	55	110.3	55
072.25 UGB 41	1" 25 mm	UNF 1 5/8"-12	55	110.3	55
072.33 DGB 48	1 1/2" 33 mm	BSP 1 1/2"	65	137.5	83
072.33 NGB 48	1 1/2" 33 mm	NPT 1 1/2"	65	137.5	83
072.33 UGB 48	1 1/2" 33 mm	UNF 1 7/8"-12	65	137.5	83

PLUGS STECKNIPPEL

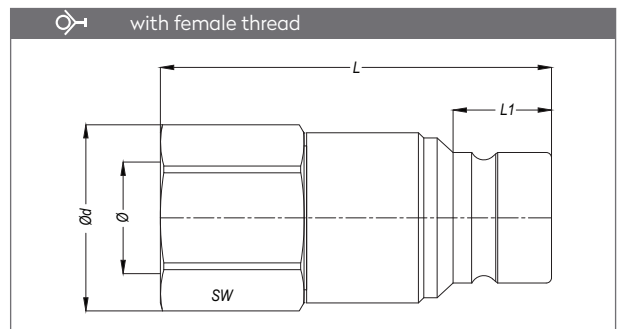

Part no.	DN	Ø	SW	L	L1	Ød
072.06 DUB 13	1/4" 6 mm	BSP 1/4"	22	50.7	12	24
072.06 NUB 13	1/4" 6 mm	NPT 1/4"	22	49.7	12	24
072.06 UUB 14	1/4" 6 mm	UNF 9/16"-18	22	49.7	12	24
072.10 DUB 17	3/8" 10 mm	BSP 3/8"	25	58.7	16.8	28.7
072.10 DUB 21	3/8" 10 mm	BSP 1/2"	27	61.7	16.8	30
072.10 NUB 17	3/8" 10 mm	NPT 3/8"	25	58.7	16.8	28.7
072.10 NUB 21	3/8" 10 mm	NPT 1/2"	27	61.7	16.8	30
072.10 UUB 14	3/8" 10 mm	UNF 9/16"-18	27	59.7	16.8	31
072.10 UUB 19	3/8" 10 mm	UNF 3/4"-16	27	62.7	16.8	31
072.12 DUB 21	1/2" 12 mm	BSP 1/2"	32	73.2	18.5	35
072.12 NUB 21	1/2" 12 mm	NPT 1/2"	32	70.2	18.5	35
072.12 UUB 22	1/2" 12 mm	UNF 7/8"-14	35	74.2	18.5	38
072.12 DUB 26	1/2" 12 mm	BSP 3/4"	35	72.2	18.5	38
072.12 NUB 26	1/2" 12 mm	NPT 3/4"	35	74.2	18.5	38
072.12 UUB 27	1/2" 12 mm	UNF 11/16"-12	35	78.2	18.5	38
072.16 DUB 26	5/8" 16 mm	BSP 3/4"	38	75.2	17.3	41.5
072.16 NUB 26	5/8" 16 mm	NPT 3/4"	38	75.2	17.3	41.5
072.16 UUB 27	5/8" 16 mm	UNF 11/16"-12	38	74.2	17.3	41.5
072.19 DUB 33	3/4" 19 mm	BSP 1"	46	81.5	23.6	50
072.19 NUB 33	3/4" 19 mm	NPT 1"	46	85	23.6	50
072.19 UUB 33	3/4" 19 mm	UNF 15/16"-12	38	83.5	23.6	41.5
072.25 DUB 42	1" 25 mm	BSP 1 1/4"	55	90	23.5	60
072.25 NUB 42	1" 25 mm	NPT 1 1/4"	55	90	23.5	60
072.25 UUB 41	1" 25 mm	UNF 1 5/8"-12	55	90	23.5	60
072.33 DUB 48	1 1/2" 33 mm	BSP 1 1/2"	70	112.2	31	74
072.33 NUB 48	1 1/2" 33 mm	NPT 1 1/2"	70	112.3	31	74
072.33 UUB 48	1 1/2" 33 mm	UNF 1 7/8"-12	70	112.3	31	74

WATERBLAST COUPLINGS

HOCHDRUCKWASSERSTRAHLEN KUPPLUNGEN

DN12 SERIE 091



Materials

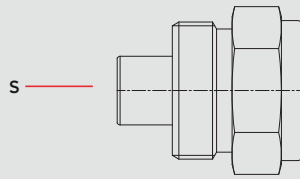
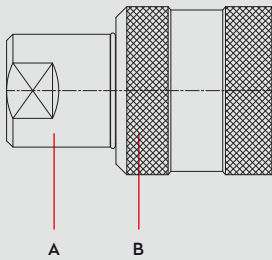

Material Code

A = AISI 316

B = AISI 316

S = AISI 316



0 - 1000 bar



-40°C to + 105°C (NBR)

Shut Off Type



Applications

- Waterblast
- High Pressure
- Wireline - Grease Injection
- Water Jetting

Compatible with

 DNP
DIXON

 CRS SERIES
TD SERIES

DN

12 mm

QUICK COUPLINGS SCHNELLKUPPLUNGEN

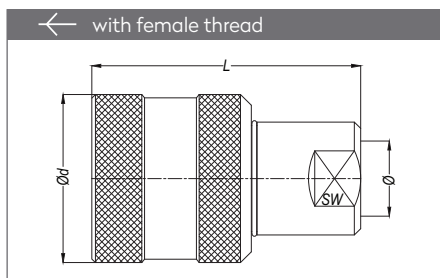

Part No.	Ø	L	Ød	SW
091 DGF 21	BSP 1/2"	75	46.9	28.5
091 NGF 21	NPT 1/2"	75	46.9	28.5

PLUGS STECKNIPPEL

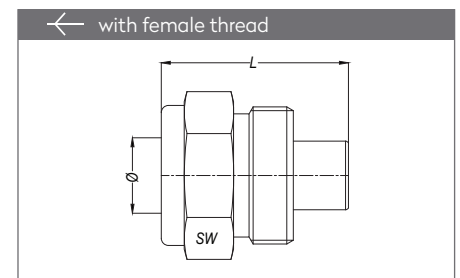

Part No.	Ø	SW	L
091 DU 21	BSP 1/2"	41	52
091 NU 21	NPT 1/2"	41	52

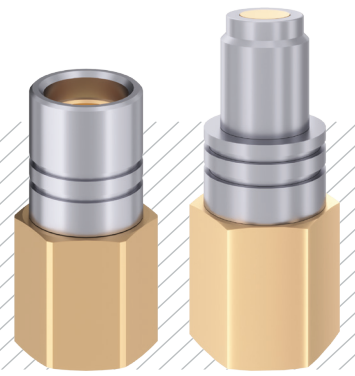

Materials

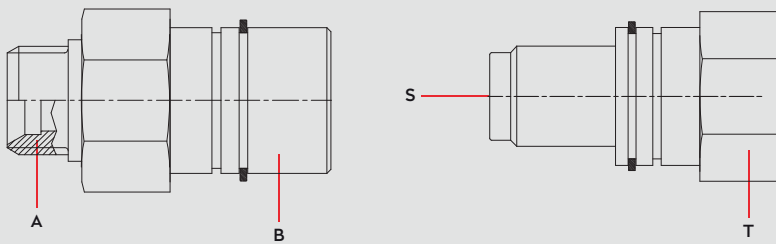

Material Code

- A = Brass
- B = AISI 420
- S = AISI 420
- T = Brass



0 - 20 bar



-26°C to + 200°C (FPM)

Shut Off Type





COUPLING

- OV262 - 01235
- OV200 - 00500
- OV157 - 01800

PLUG

- OV200 - 00500
- OV157 - 01800

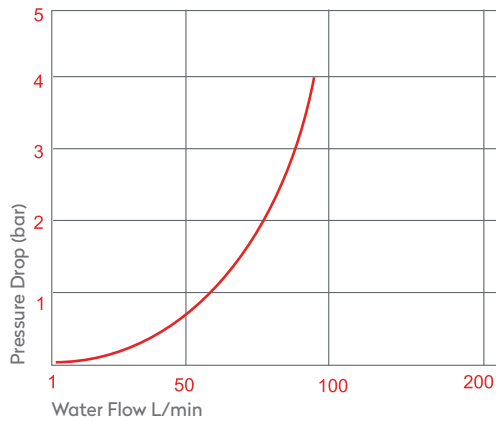
DN 8 mm



Options

EPDM

Applications

- Multi couplers for the mould
- Robotic tool changer couplers

Compatible with

HASCO Z809 - Z819

AUTOMATIC COUPLINGS
 AUTOMATISCHE KUPPLUNGEN

SERIE 093

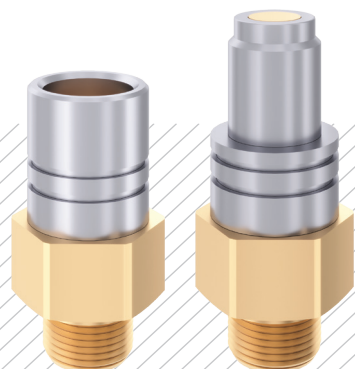

QUICK COUPLINGS SCHNELLKUPPLUNGEN

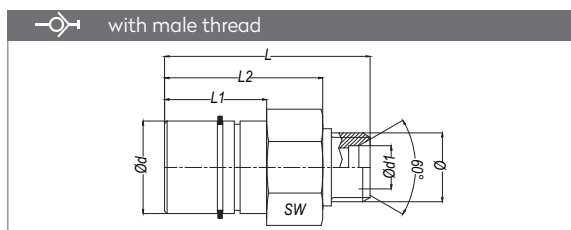

Part No.	DN	Ø	Ød	Ød1	L	L1	L2	SW
093.08 EGBM 16-10	08	M16x1.5	21.5	10	47.8	23.8	36.8	24
093.08 EGB 17	08	BSP 3/8"	21.5	10	47.8	23.8	36.8	24

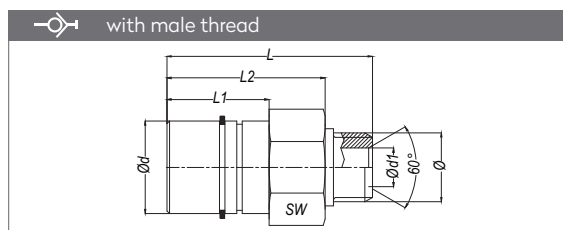

Part No.	DN	Ø	Ød	Ød1	L	L1	L2	SW
093.08 EGBM 16-10	08	M16x1.5	21.5	10	47.8	23.8	36.8	24

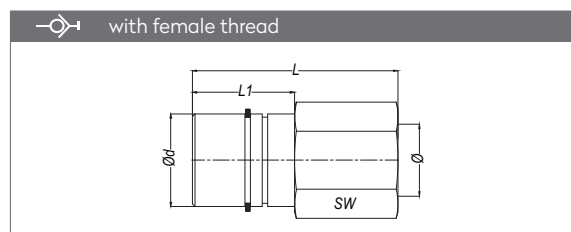

Part No.	DN	Ø	Ød	L	L1	SW
093.08 DGBM 16	08	M16x1.5	21.5	47.8	23.8	24
093.08 DGB 17	08	BSP 3/8"	21.5	47.8	23.8	24
093.08 DGB 21	08	BSP 1/2"	21.5	47.8	23.8	24

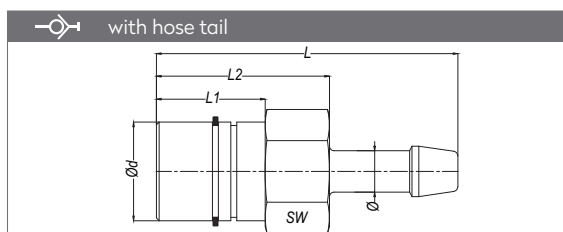

Part No.	DN	Ø	Ød	L	L1	L2	SW
093.08 HGB 10	08	Ø10	21.5	65.8	23.8	37.8	24
093.08 HGB 13	08	Ø13	21.5	65.8	23.8	37.8	24

PLUGS STECKNIPPEL

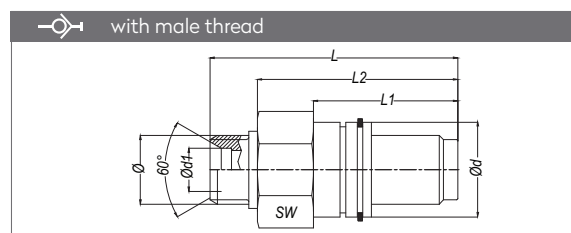

Part No.	DN	Ø	Ød	Ød1	L	L1	L2	SW
093.08 EUBM 16-10	08	M16x1.5	22	10	57.5	33.5	46.5	24
093.08 EUB 17	08	BSP 3/8"	22	10	57.5	33.5	46.5	24

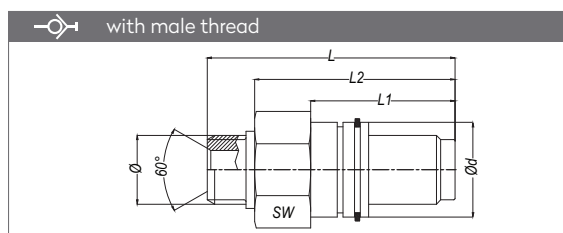

Part No.	DN	Ø	Ød	L	L1	L2	SW
093.08 EUBM 16	08	M16x1.5	22	57.5	33.5	46.5	24

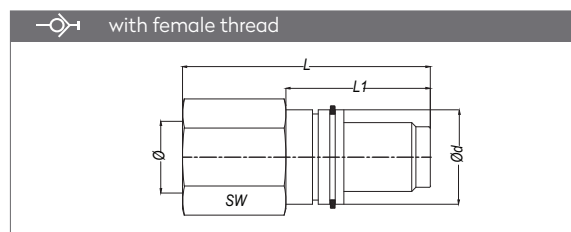

Part No.	DN	Ø	Ød	L	L1	SW
093.08 DUBM 16	08	M16x1.5	22	57.5	33.5	24
093.08 DUB 17	08	BSP 3/8"	22	57.5	33.5	24
093.08 DUB 21	08	BSP 1/2"	22	57.5	33.5	24

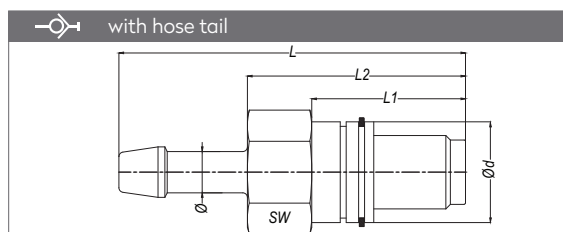

Part No.	DN	Ø	Ød	L	L1	L2	SW
093.08 HUB 10	08	Ø10	22	57.5	33.5	46.5	24
093.08 HUB 13	08	Ø13	22	57.5	33.5	46.5	24

AUTOMATIC COUPLINGS
AUTOMATISCHE KUPPLUNGEN

SERIE 098

DN 6-12

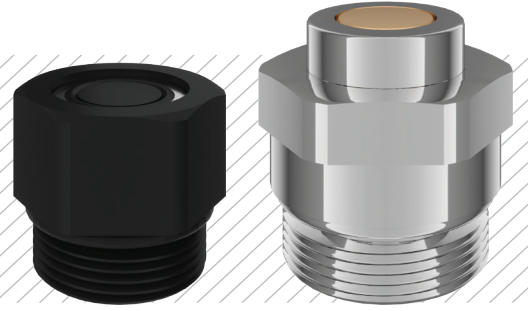

Materials

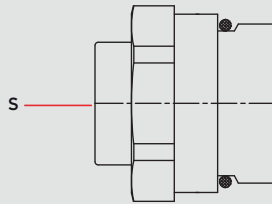
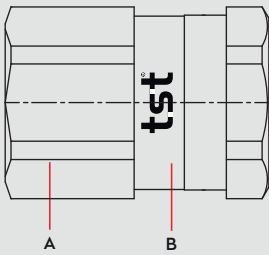

Material Code

098.06

098.08/098.12

B = Aluminium
Black

A = Brass

B = Brass

S = Brass
Chrome Plated

S = Brass
Chrome Plated



0 - 16 bar → Standard
0-100 bar → AISI 303



-26°C to + 200°C (FPM)

**Shut Off
Type**



COUPLING

TST 098.06

OV157 - 01500

OV178 - 01520

TST 098.08

OV262 - 1870

OV178 - 2035

TST 098.12

OV262 - 02665

OV178 - 02985

PLUG

TST 098.06

OV157 - 01500

OV120 - 00800

TST 098.08

OV157 - 01000

OV178 - 02035

TST 098.12

OV200 - 01650

OV178 - 02985

DN 6-8-12 mm

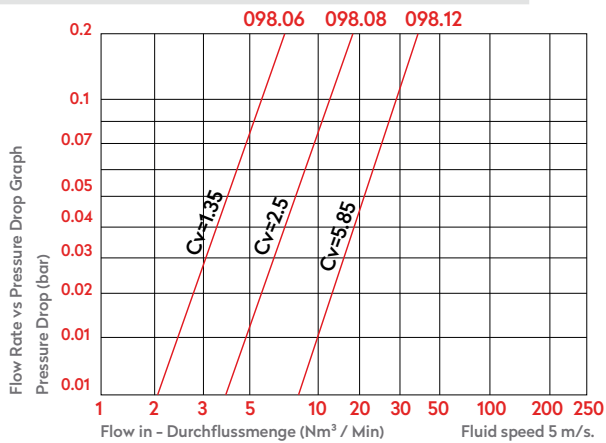

Options

AISI303
Stainless Steel

Applications

- Multi couplers for the mould
- Robotic tool changer couplers

Compatible with

AUTOMATIC COUPLINGS
 AUTOMATISCHE KUPPLUNGEN

SERIE 098

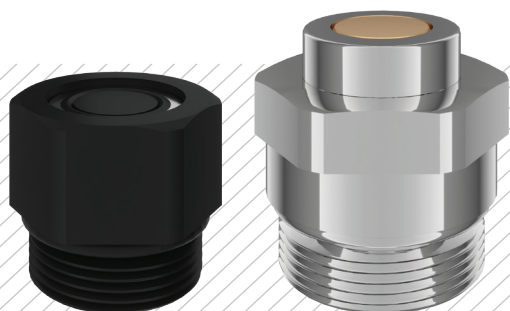

QUICK COUPLINGS SCHNELLKUPPLUNGEN

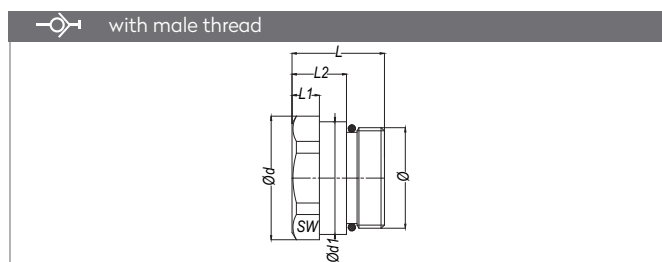

Part No.	DN	Ø	Ød	Ød1	L	L1	L2	SW
098.06 EGBM 18	06	M18x1	22	-	18.2	11	-	20
098.08 EGBM 24	08	M24x1.5	29.5	26.9	22	6.5	13	27
098.12 EGBM 33	12	M33x1.5	41.5	37.9	22	6.5	13	38

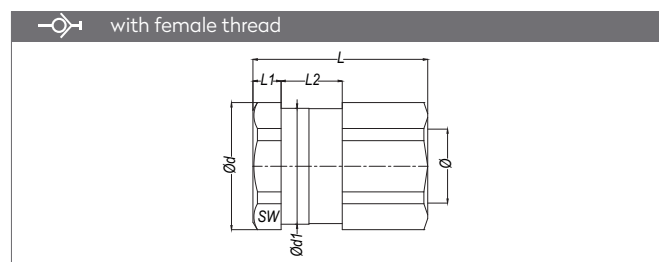

Part No.	DN	Ø	Ød	Ød1	L	L1	L2	SW
098.08 DGB 17	08	BSP 3/8"	29.5	26.9	40.5	6.5	14.2	27
098.12 DGB 26	12	BSP 3/4"	41.5	37.9	44	6.5	14.2	38

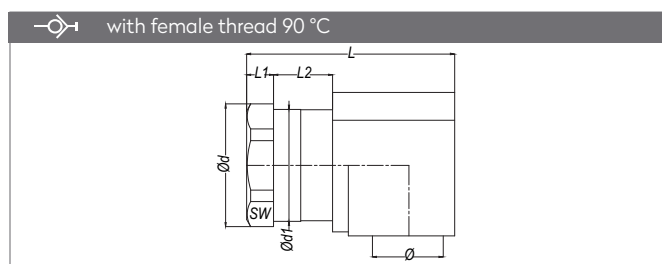

Part No.	DN	Ø	Ød	Ød1	L	L1	L2	SW
098.08 DGB 17-90	08	BSP 3/8"	29.5	26.9	50	6.5	14.2	27
098.12 DGB 26-90	12	BSP 3/4"	41.5	37.9	60	6.5	14.2	38

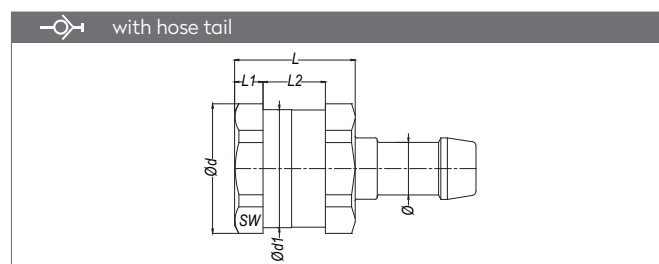

Part No.	DN	Ø	Ød	Ød1	L	L1	L2	SW
098.08 HGB 12	08	Ø 12	30	30	31.5	6.5	14.2	27
098.12 HGB 16	12	Ø 16	42	42	35	6.5	14.2	38

PLUGS STECKNIPPEL

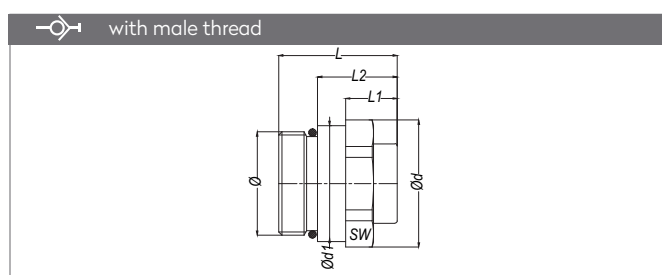

Part No.	DN	Ø	Ød	Ød1	L	L1	L2	SW
098.06 EUBM 18	06	M18x1	22	-	23.5	16.3	-	20
098.08 EUBM 24	08	M24x1.5	29.5	26.9	27.5	12	18.5	27
098.12 EUBM 33	12	M33x1.5	41.5	37.9	27.5	12	18.5	38

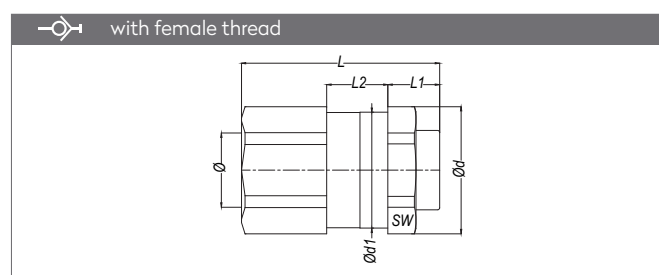

Part No.	DN	Ø	Ød	Ød1	L	L1	L2	SW
098.08 DUB 17	08	BSP 3/8"	29.5	26.9	46	12	14.2	27
098.12 DUB 26	12	BSP 3/4"	41.5	37.9	49.5	12	14.2	38

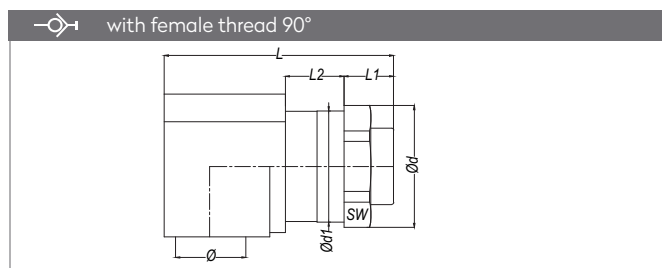

Part No.	DN	Ø	Ød	Ød1	L	L1	L2	SW
098.08 DUB 17-90	08	BSP 3/8"	29.5	26.9	55	12	14.2	27
098.12 DUB 26-90	12	BSP 3/4"	41.5	37.9	63	12	14.2	38

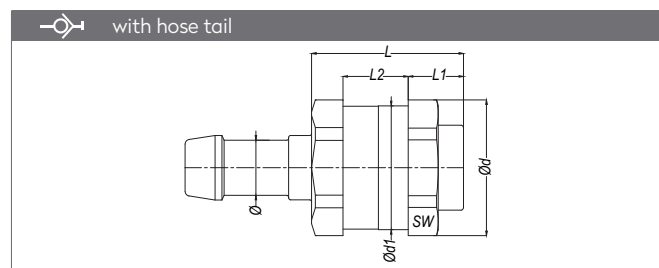

Part No.	DN	Ø	Ød	Ød1	L	L1	L2	SW
098.08 HUB 12	08	Ø 12	30	26.9	36.7	11.5	14.2	27
098.12 HUB 16	12	Ø 16	42	37.9	40.5	11.5	14.2	38



Materials

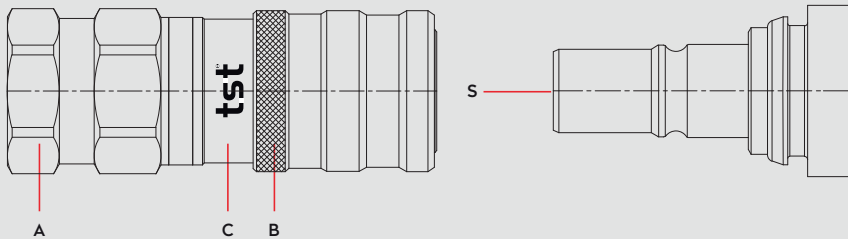

Material Code

099.09/099.12	099.16
A = Brass Nickel Plated	A = Brass Nickel Plated
B = AISI 303	B = AISI 420
C = Brass Nickel Plated	C = Brass Chemical Nickel Plated
S = Brass Nickel Plated	S = AISI 420 Chrome Plated

0 - 16 bar → 150°C
0 - 10 bar → 150°C

-26°C to + 200°C (FPM)

Shut Off Type

COUPLING	TST 099.09	TST 099.12	TST 099.16
	OV 178 - 01715 OV 178 - 00870 OV 262 - 01235	OV 280 - 01600 OV 262 - 01075 OV 157 - 01600	OV 262 - 02105 OV 262 - 01510 OV 200 - 02000
PLUG	TST 099.09	TST 099.12	TST 099.16
	OV 250 - 00600 OV 157 - 01400	OV 205 - 00870 OV 178 - 02350	OV 262 - 01235 OV 178 - 02985

DN

TST 099.09 → 9 mm
TST 099.12 → 12 mm
TST 099.16 → 16 mm

Options

Id. Ring EPDM

Applications

- Hot oil circuits
- Cooling systems
- Railway

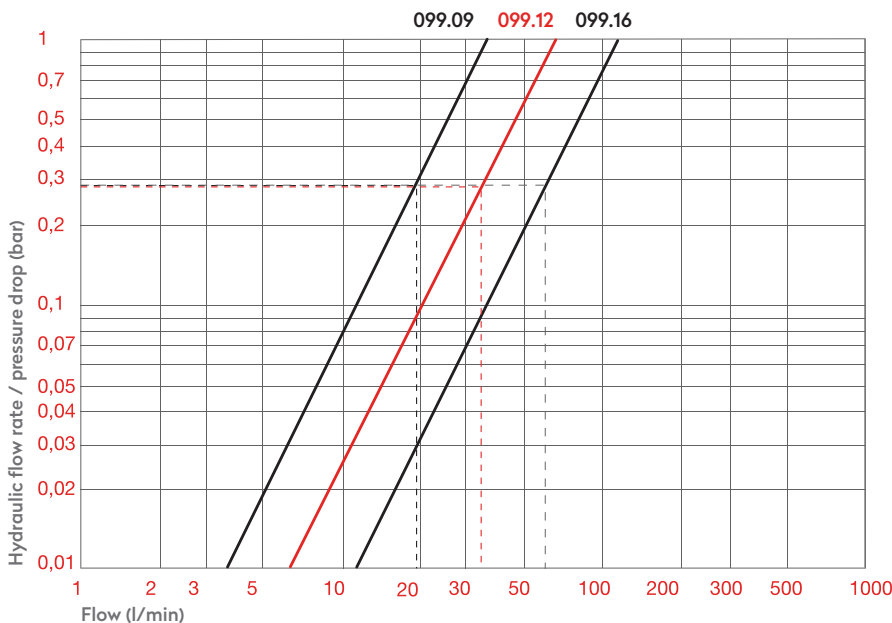

MOULD COOLING COUPLINGS

KÜHLUNGSELEMENTE FÜR WERKZEUGE

SERIE 099



QUICK COUPLINGS SCHNELLKUPPLUNGEN

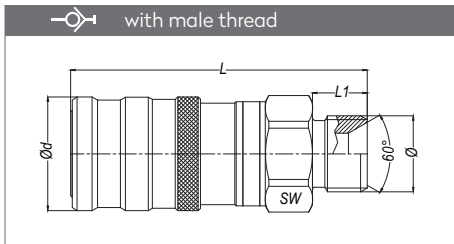

Part no.	Ø	DN	Ød	L	L1	SW
099.09 EGB 17	BSP 3/8"	9	24.9	66	12	23
099.12 EGB 21	BSP 1/2"	12	31	79.8	14	30
099.16 EGB 26	BSP 3/4"	16	38	98	16	32

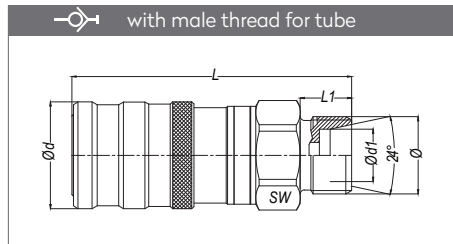

Part no.	Ø	DN	Ød	Ød1	L	L1	SW
099.09 EGBM 18-12	M18x1.5	9	24.9	12	65	11	23
099.12 EGBM 26-18	M26x1.5	12	31	18	79.8	12	30
099.16 EGBM 30-22	M30x2	16	38	22	98	14	32

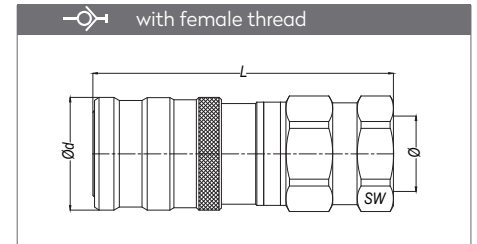

Part no.	Ø	DN	Ød	L	SW
099.09 DGB 17	BSP 3/8"	9	24.9	66.5	23
099.09 NGB 17	NPT 3/8"	9	24.9	65.1	23
099.12 DGB 21	BSP 1/2"	12	31	79.8	30
099.12 NGB 21	NPT 1/2"	12	31	81.8	30
099.16 DGB 26	BSP 3/4"	16	38	99.3	35
099.16 NGB 26	NPT 3/4"	16	38	99.3	35

VALVED PLUGS VERSCHLUSSNIPPEL

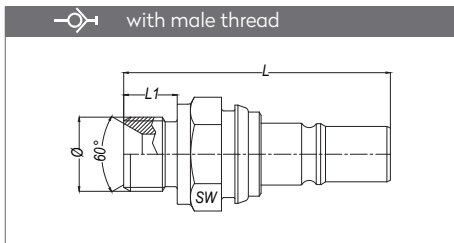

Part no.	Ø	DN	L	L1	SW
099.09 EUB 17	BSP 3/8"	9	60	12	23
099.12 EUB 21	BSP 1/2"	12	75	14	30
099.16 EUB 26	BSP 3/4"	16	99	16	36

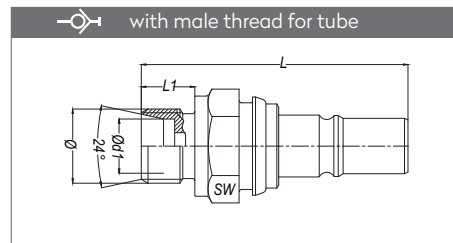

Part no.	Ø	DN	Ød1	L	L1	SW
099.09 EUBM 18-12	M18x1.5	9	12	59	11	23
099.12 EUBM 26-18	M26x1.5	12	18	71.5	12	30
099.16 EUBM 30-22	M30x2	16	22	95	14	36

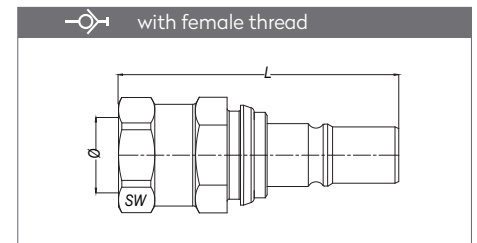

Part no.	Ø	DN	L	SW
099.09 DUB 17	BSP 3/8"	9	62	23
099.09 NUB 17	NPT 3/8"	9	61	23
099.12 DUB 21	BSP 1/2"	12	71.2	30
099.12 NUB 21	NPT 1/2"	12	78.2	30
099.16 DUB 26	BSP 3/4"	16	102	36
099.16 NUB 26	NPT 3/4"	16	105	36

SERIE 100



MOULD COOLING COUPLINGS

KÜHLUNGSELEMENTE FÜR WERKZEUGE

DN 6-8-12

SERIE 100



Materials

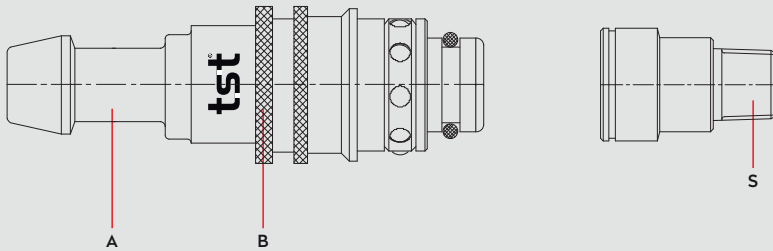

Material Code

A = Brass Nickel Plated

B = Brass Nickel Plated

S = Brass Nickel Plated



0 - 10 bar



-40°C to + 105°C (NBR)

Shut Off Type



TST 100.06 → OM 178 - 00720
 TST 100.08 → OM 178 - 00925
 TST 100.12 → OM 220 - 01500

French Serie

DN

TST 100.06 → 6 mm
 TST 100.08 → 8 mm
 TST 100.12 → 12 mm

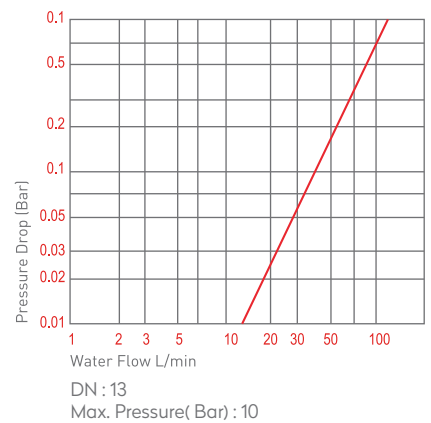
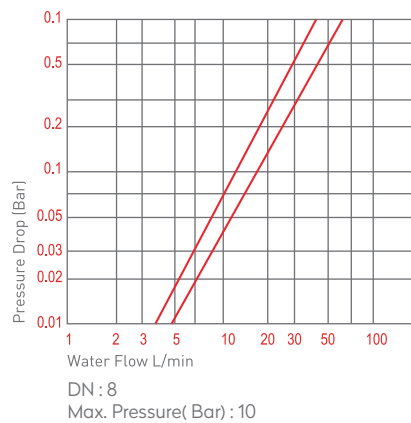
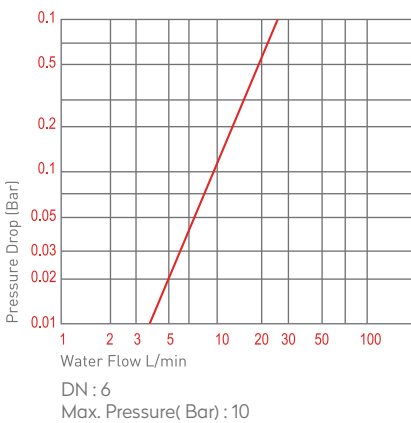

Options



Id.
Ring

FPM

E2

Applications

- Cold - hot fluid circuits
- Temperature control

Compatible with

PARKER

608- 612

MOULD COOLING COUPLINGS

KÜHLUNGSELEMENTE FÜR WERKZEUGE

SERIE 100



PLUGS STECKNIPPEL

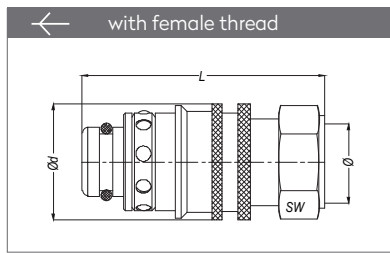

Part No.	Ø	Ød	L	SW
100.08 DGF 13	BSP 1/4"	20	44	17
100.08 DGF 17	BSP 3/8"	20	53	19
100.08 NGF 13	NPT 1/4"	20	44	17
100.08 NGF 17	NPT 3/8"	20	52	19
100.12 DGF 21	BSP 1/2"	27.5	60	24
100.12 NGF 21	NPT 1/2"	27.5	65	24
100.12 DGF 26	BSP 3/4"	27.5	66	30
100.12 NGF 26	NPT 3/4"	27.5	69	30

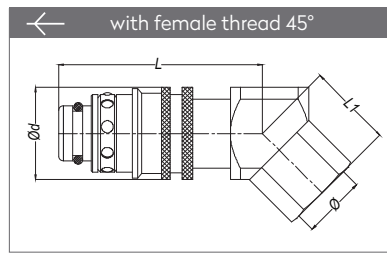

Part No.	Ø	Ød	L	L1
100.08 DGF 13-45°	BSP 1/4"	20	45	13.5
100.08 DGF 17-45°	BSP 3/8"	20	45	13.5
100.08 NGF 13-45°	NPT 1/4"	20	45	14.2
100.08 NGF 17-45°	NPT 3/8"	20	45	15.7
100.12 DGF 17-45°	BSP 3/8"	27.5	54	14.5
100.12 NGF 17-45°	NPT 3/8"	27.5	54	17.3
100.12 DGF 21-45°	BSP 1/2"	27.5	54	20.1
100.12 NGF 21-45°	NPT 1/2"	27.5	54	21.5

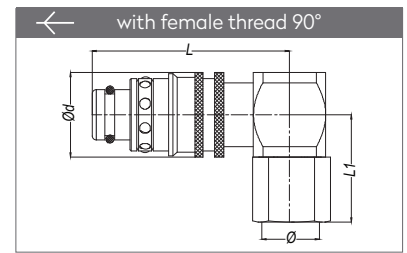

Part No.	Ø	Ød	L	L1
100.08 DGF 13-90°	BSP 1/4"	20	46.5	24
100.08 DGF 17-90°	BSP 3/8"	20	46.5	24
100.08 NGF 13-90°	NPT 1/4"	20	46.5	25
100.08 NGF 17-90°	NPT 3/8"	20	46.5	27
100.12 DGF 17-90°	BSP 3/8"	27.5	54	29
100.12 NGF 17-90°	NPT 3/8"	27.5	54	31.5
100.12 DGF 21-90°	BSP 1/2"	27.5	54	36.5
100.12 NGF 21-90°	NPT 1/2"	27.5	54	38.5

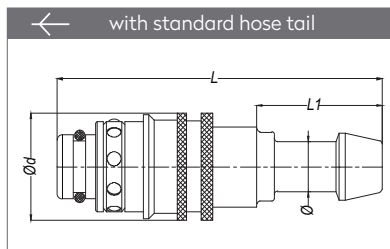

Part No.	Ø	Ød	L	L1
100.06 HGF 06	Ø6 mm	17	55	22.5
100.06 HGF 08	Ø8 mm	17	55	22.5
100.06 HGF 10	Ø10 mm	17	55	22.5
100.08 HGF 06	Ø6 mm	20	62	27.5
100.08 HGF 08	Ø8 mm	20	62	27.5
100.08 HGF 10	Ø10 mm	20	62	27.5
100.08 HGF 12	Ø12 mm	20	62	27.5
100.08 HGF 13	Ø13 mm	20	62	22.5
100.12 HGF 13	Ø13 mm	27.5	76	33
100.12 HGF 16	Ø16 mm	27.5	76	33

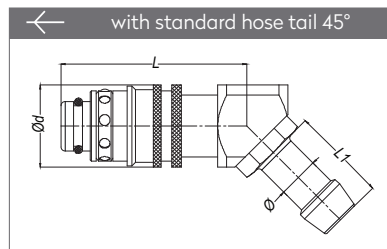

Part No.	Ø	Ød	L	L1
100.06 HGF 06-45°	Ø6 mm	17	39	23
100.06 HGF 08-45°	Ø8 mm	17	39	23
100.06 HGF 10-45°	Ø10 mm	17	39	23
100.08 HGF 06-45°	Ø6 mm	20	45	23
100.08 HGF 08-45°	Ø8 mm	20	45	23
100.08 HGF 10-45°	Ø10 mm	20	45	23
100.08 HGF 12-45°	Ø12 mm	20	45	23
100.08 HGF 13-45°	Ø13 mm	20	45	23
100.12 HGF 13-45°	Ø13 mm	27.5	54	27.5
100.12 HGF 16-45°	Ø16 mm	27.5	54	27.5

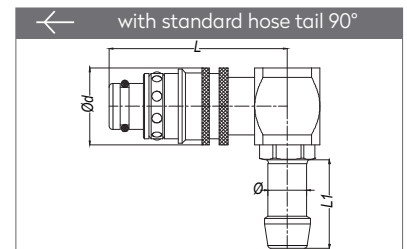

Part No.	Ø	Ød	L	L1
100.06 HGF 06-90°	Ø6 mm	17	40.3	23
100.06 HGF 08-90°	Ø8 mm	17	40.3	23
100.06 HGF 10-90°	Ø9 mm	17	40.3	23
100.08 HGF 06-90°	Ø6 mm	20	46.5	23
100.08 HGF 08-90°	Ø8 mm	20	46.5	23
100.08 HGF 10-90°	Ø10 mm	20	46.5	23
100.08 HGF 12-90°	Ø12 mm	20	46.5	23
100.08 HGF 13-90°	Ø13 mm	27.5	46.5	23
100.12 HGF 13-90°	Ø13 mm	27.5	54	27.5
100.12 HGF 16-90°	Ø16 mm	27.5	54	27.5

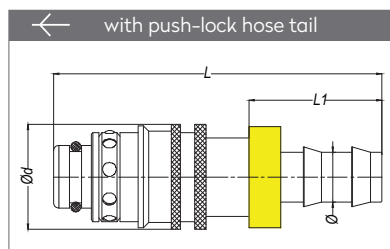

Part No.	Ø	Ød	L	L1
100.06 FGF 06	Ø6 mm	17	57	24
100.06 FGF 08	Ø8 mm	17	57	24
100.06 FGF 10	Ø10 mm	17	57	24
100.08 FGF 10	Ø10 mm	20	62	24
100.08 FGF 13	Ø13 mm	20	69	28
100.12 FGF 13	Ø13 mm	27.5	71	28
100.12 FGF 16	Ø16 mm	27.5	82	38

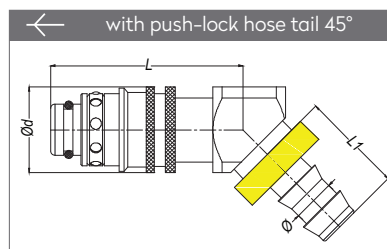

Part No.	Ø	Ød	L	L1
100.08 FGF 10-45°	Ø10 mm	20	45	24
100.08 FGF 13-45°	Ø13 mm	20	45	28
100.12 FGF 13-45°	Ø13 mm	27.5	54	28
100.12 FGF 16-45°	Ø16 mm	27.5	54	28

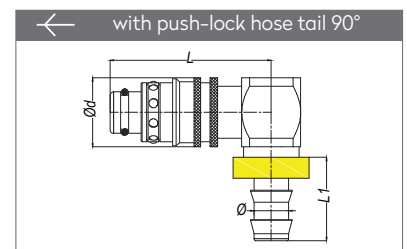

Part No.	Ø	Ød	L	L1
100.08 FGF 10-90°	Ø10 mm	20	46.5	24
100.08 FGF 13-90°	Ø13 mm	20	46.5	28
100.12 FGF 13-90°	Ø13 mm	27.5	54	28
100.12 FGF 16-90°	Ø16 mm	27.5	54	28

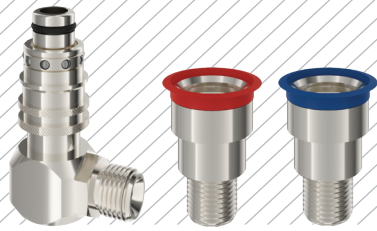
 MOULD COOLING COUPLINGS
 KÜHLUNGSELEMENTE FÜR WERKZEUGE

SERIE 100

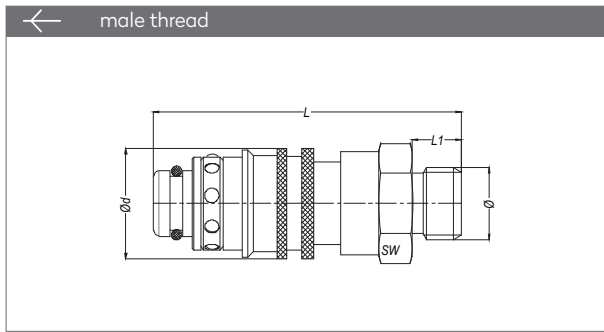

Part No.	Ø	Ød	L	L1	SW
100.08 EGF 13	BSP 1/4"	20	58	9	19
100.08 EGF 17	BSP 3/8"	20	59	10	19
100.12 EGF 17	BSP 3/4"	27.5	61	10	24

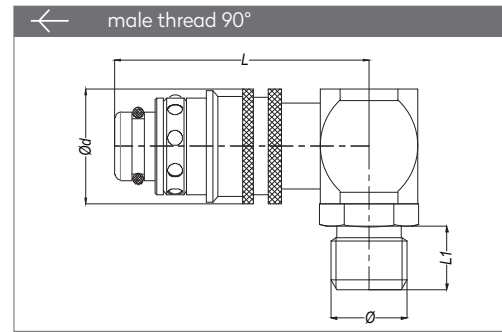

Part No.	Ø	Ød	L	L1
100.08 EGF 13-90	BSP 1/4"	20	46.5	11
100.08 EGF 17-90	BSP 3/8"	20	46.5	11
100.12 EGF 17-90	BSP 3/8"	27.5	54	9

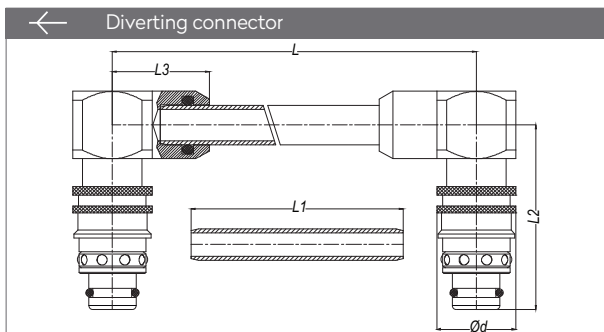

Part No.	L	L1	L2	L3
100.08 - KG 125	125	101	45	24.5
100.08 - KG 250	250	226	45	24.5
100.08 - KG 500	500	476	45	24.5
100.12 - KG 125	125	95	54	27
100.12 - KG 250	250	220	54	27
100.12 - KG 500	500	470	54	27

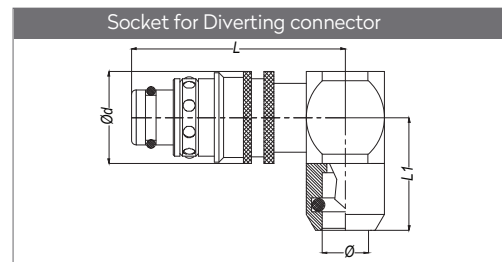

Part No.	Ø	Ød	L	L1
100.08 KG 00	10	20	46.5	24.5
100.12 KG 00	14	27.5	54	27

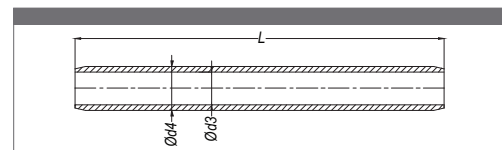

Part no. for Brass Tube	Ød3	Ød4
100.08 KPb x Length	8	10
100.12 KPb x Length	12	14

Colour identification Rings for Couplings Markierungsringe für Kupplungen



Serie	Part no. / Blue	Part no. / Red
100.06	100.06 KB 00	100.06 KR 00
100.08	100.08 KB 00	100.08 KR 00
100.12	100.12 KB 00	100.12 KR 00

MOULD COOLING COUPLINGS

KÜHLUNGSELEMENTE FÜR WERKZEUGE

SERIE 100



VALVED PLUGS VERSCHLUSSNIPPEL

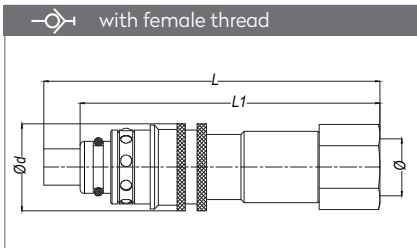

Part No.	Ø	Ød	L	L1
100.08 DGB 13	BSP 1/4"	20	78	68
100.08 DGB 17	BSP 3/8"	20	78	68
100.08 NGB 13	NPT 1/4"	20	79	69
100.08 NGB 17	NPT 3/8"	20	81	71
100.12 DGB 21	BSP 1/2"	27.5	90	80
100.12 NGB 21	NPT 1/2"	27.5	90	80

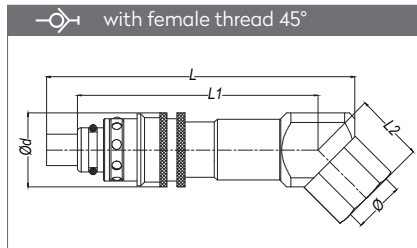

Part No.	Ø	Ød	L	L1	L2
100.08 DGB 13-45°	BSP 1/4"	20	84	64.5	18.6
100.08 DGB 17-45°	BSP 3/8"	20	84	64.5	18.6
100.08 NGB 13-45°	NPT 1/4"	20	84	64.5	19.6
100.08 NGB 17-45°	NPT 3/8"	20	84	64.5	21.6
100.12 DGB 17-45°	BSP 3/8"	27.5	106	83	24
100.12 NGB 17-45°	NPT 3/8"	27.5	106	83	30
100.12 DGB 21-45°	BSP 1/2"	27.5	106	83	27
100.12 NGB 21-45°	NPT 1/2"	27.5	106	83	34

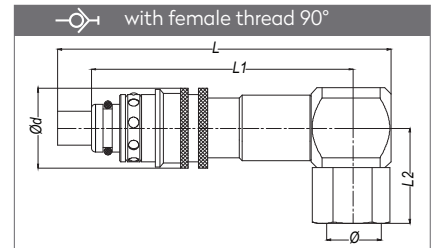

Part No.	Ø	Ød	L	L1	L2
100.08 DGB 13-90°	BSP 1/4"	20	84.5	64.5	24
100.08 DGB 17-90°	BSP 3/8"	20	84.5	64.5	24
100.08 NGB 13-90°	NPT 1/4"	20	84.5	64.5	25
100.08 NGB 17-90°	NPT 3/8"	20	84.5	64.5	27
100.12 DGB 17-90°	BSP 3/8"	27.5	92.3	74	29
100.12 NGB 17-90°	NPT 3/8"	27.5	92.3	74	31.5
100.12 DGB 21-90°	BSP 1/2"	27.5	92.3	74	36.5
100.12 NGB 21-90°	NPT 1/2"	27.5	92.3	74	38.5

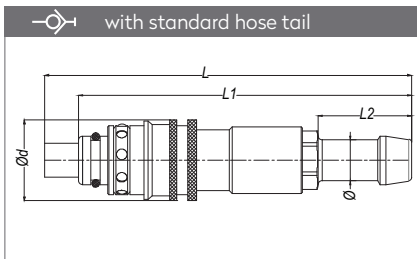

Part No.	Ø	Ød	L	L1	L2
100.08 HGB 06	Ø6 mm	20	91	81	23
100.08 HGB 08	Ø8 mm	20	91	81	23
100.08 HGB 10	Ø10 mm	20	91	81	23
100.08 HGB 12	Ø12 mm	20	91	81	23
100.08 HGB 13	Ø13 mm	20	91	81	23
100.12 HGB 13	Ø13 mm	27.5	102	92	27.5
100.12 HGB 16	Ø16 mm	27.5	102	92	27.5

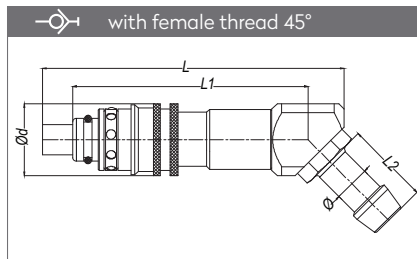

Part No.	Ø	Ød	L	L1	L2
100.08 HGB 06-45°	Ø6 mm	20	84	64.5	23
100.08 HGB 08-45°	Ø8 mm	20	84	64.5	23
100.08 HGB 10-45°	Ø10 mm	20	84	64.5	23
100.08 HGB 12-45°	Ø12 mm	20	84	64.5	23
100.08 HGB 13-45°	Ø13 mm	20	84	83	23
100.12 HGB 13-45°	Ø13 mm	27.5	106	83	27.5
100.12 HGB 16-45°	Ø16 mm	27.5	106	83	27.5

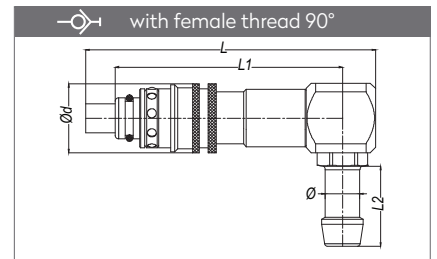

Part No.	Ø	Ød	L	L1	L2
100.08 HGB 06-90°	Ø6 mm	20	84.5	64.5	23
100.08 HGB 08-90°	Ø8 mm	20	84.5	64.5	23
100.08 HGB 10-90°	Ø10 mm	20	84.5	64.5	23
100.08 HGB 12-90°	Ø12 mm	20	84.5	64.5	23
100.08 HGB 13-90°	Ø13 mm	20	84.5	64.5	23
100.12 HGB 13-90°	Ø13 mm	27.5	92.3	74	27.5
100.12 HGB 16-90°	Ø16 mm	27.5	92.3	74	27.5

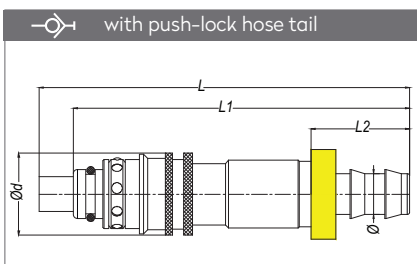

Part No.	Ø	Ød	L	L1	L2
100.08 FGB 10	Ø10 mm	20	92	82	24
100.08 FGB 13	Ø13 mm	20	96	86	24
100.12 FGB 13	Ø13 mm	27.5	102	92	28
100.12 FGB 16	Ø16 mm	27.5	102	92	28

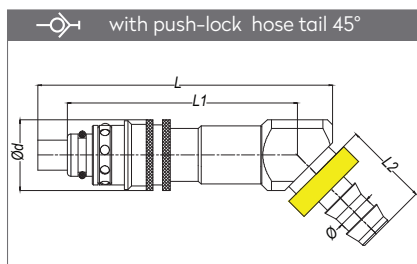

Part No.	Ø	Ød	L	L1	L2
100.08 FGB 10-45°	Ø10 mm	20	84.5	64.5	24
100.08 FGB 13-45°	Ø13 mm	20	84.5	64.5	24
100.12 FGB 13-45°	Ø13 mm	27.5	92.3	74	28
100.12 FGB 16-45°	Ø16 mm	27.5	92.3	74	28

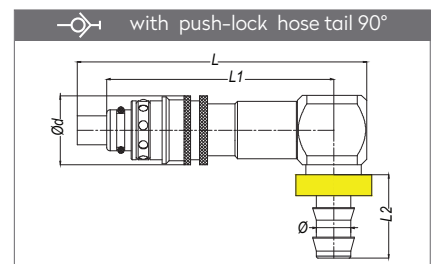

Part No.	Ø	Ød	L	L1	L2
100.08 FGB 10-90°	Ø10 mm	20	84.5	64	24
100.08 FGB 13-90°	Ø13 mm	20	84.5	64	24
100.12 FGB 13-90°	Ø13 mm	27.5	92.3	74	28
100.12 FGB 16-90°	Ø16 mm	27.5	92.3	74	28

 MOULD COOLING COUPLINGS
 KÜHLUNGSELEMENTE FÜR WERKZEUGE

SERIE 100

QUICK COUPLINGS SCHNELLKUPPLUNGEN

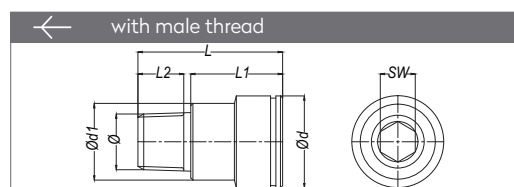

Part No.	Ø	Ød	Ød1	L1	L2	L	SW
100.06 RU 10	BSPT 1/8"	17	14	18.5	10	28.5	6
100.06 RU 13	BSPT 1/4"	17	14	18.5	12	30.5	6
100.08 RU 10	BSPT 1/8"	21	17.5	21	10	31	6
100.08 RU 13	BSPT 1/4"	21	17.5	21	12	33	8
100.08 RU 17	BSPT 3/8"	21	21	11	13	24	8
100.12 RU 17	BSPT 3/8"	32	24	28	13	41	10
100.12 RU 21	BSPT 1/2"	32	24	28	16	44	14
100.12 RU 26	BSPT 3/4"	32	32	13	19	32	14

100.06 TU 10	NPT 1/8"	17	14	18.5	10	28.5	6
100.06 TU 13	NPT 1/4"	17	14	18.5	13	31.5	6
100.08 TU 10	NPT 1/8"	21	17.5	21	10	31	6
100.08 TU 13	NPT 1/4"	21	17.5	21	12	33	8
100.08 TU 17	NPT 3/8"	21	21	11	13	24	8
100.12 TU 17	NPT 3/8"	32	24	28	13	41	10
100.12 TU 21	NPT 1/2"	32	24	28	18	46	14
100.12 TU 26	NPT 3/4"	32	32	13	19	32	14

100.06 EUM 10x1	M10x1.0	17	14	18.5	10	28.5	6
100.08 EUM 10x1	M10x1.0	21	17.5	21	10	31	6
100.08 EUM 10	M10x1.5	21	17.5	21	10	31	6
100.08 EUM 12x1.75	M12x1.75	21	17.5	21	12	33	6
100.08 EUM 14	M14x1.5	21	17.5	21	10	31	8

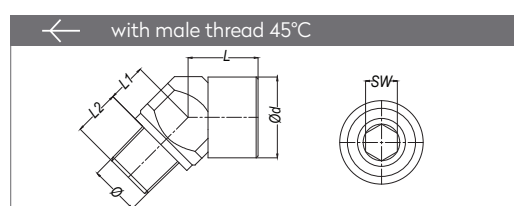

Part No.	Ø	Ød	L	L2	L1	SW
100.08 RU 10-45°	BSPT 1/8"	21	18.1	9	10	20
100.08 RU 13-45°	BSPT 1/4"	21	18.1	12	10	20
100.08 RU 17-45°	BSPT 3/8"	21	18.1	12	10	20

100.08 TU 13-45°	NPT 1/4"	21	18.1	12	10	20
------------------	----------	----	------	----	----	----

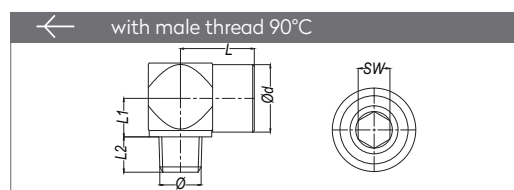

Part No.	Ø	Ød	L	L2	L1	SW
100.08 RU 10-90°	BSPT 1/8"	21	23	12	12	20
100.08 RU 13-90°	BSPT 1/4"	21	23	12	12	20
100.08 RU 17-90°	BSPT 3/8"	21	23	12	12	20

100.08 TU 13-90°	NPT 1/4"	21	23	12	12	20
------------------	----------	----	----	----	----	----

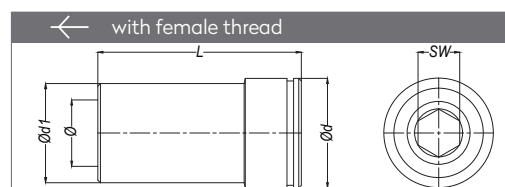

Part No.	Ø	Ød	L1	Ød1	SW
100.08 DU 10	BSP 1/8"	21	35	15	6
100.08 DU 13	BSP 1/4"	21	39	17.5	8
100.12 DU 17	BSP 3/8"	32	49	24	12
100.12 DU 21	BSP 1/2"	32	50	24	12
100.12 DU 26	BSP 3/4"	32	52	32	12

100.08 NU 10	BSP 1/8"	21	35	15	6
100.08 NU 13	BSP 1/4"	21	39	17.5	8

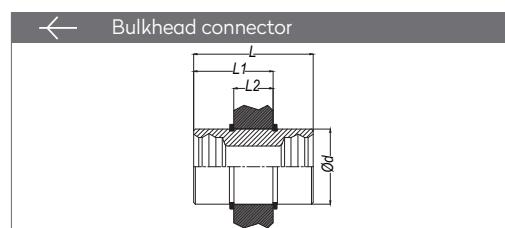

Part No.	Ød	L	L1	L2
100.08 PU 00	22	35	23	11.5 _{max}

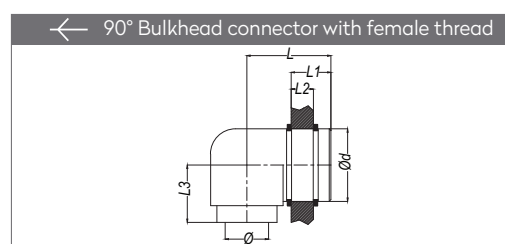

Part No.	Ø	Ød	L	L1	L2
100.08 PU 13-90	BSP 1/4"	22	25.2	11.8	6.5 _{max}

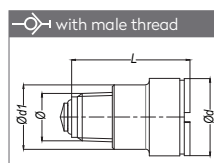

Part no.	Ø	Ød	Ød1	L
100.08 RUB 13	BSPT 1/4"	21	17.5	33
100.08 RUB 17	BSPT 3/8"	21	-	24
100.12 RUB 17	BSPT 3/8"	32	24	41
100.12 RUB 21	BSPT 1/2"	32	24	44
100.12 RUB 26	BSPT 3/4"	32	30	40

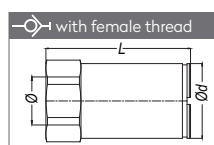

Part No.	Ø	Ød	L
100.12 DUB 21	BSP 1/2"	32	62
100.12 DUB 26	BSP 3/4"	32	62

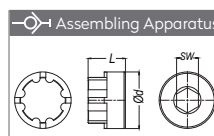

Part No.	Ø	Ød	SW	L
100.08 EUB 00	-	20.7	8	13.7
100.12 RUB 00	-	32	14	16.5

MOULD COOLING COUPLINGS
KÜHLUNGSELEMENTE FÜR WERKZEUGE

SERIE 100

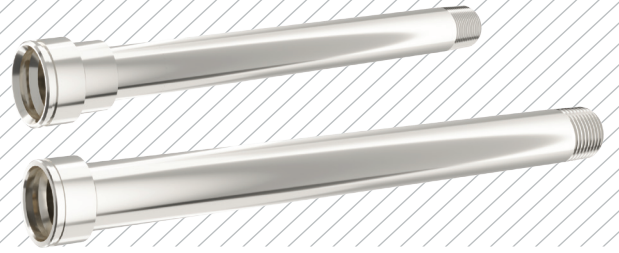

EXTENSION COUPLINGS WITH THREAD VERLÄNGERUNGSMUFFE MIT GEWINDE

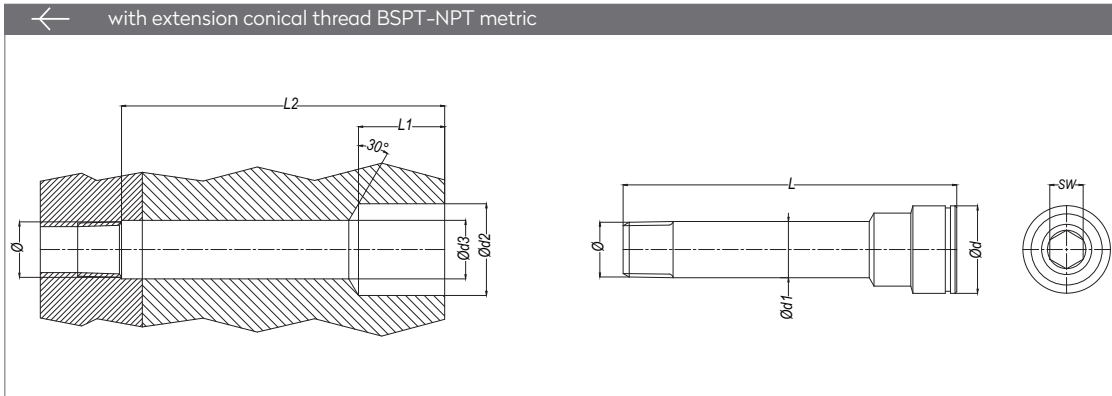

Serie	Part No.	Ø	L min/ max.	L1	L2	Ød	Ød1	Ød2	Ød3	SW	Torque Drehmoment (m/daN)
100.06	100.06-100-R10	BSPT 1/8"	33/100	20	L-5.5	17	10.3	18.5	11	6	1
	100.06-100-T10	NPT 1/8"	33/100	20	L-5.5	17	10.3	18.5	11	6	1
	100.06-100-M10	M10x1.0	33/100	20	L-5.5	17	10.3	18.5	11	6	1
100.08 BSPT	100.08-100 R10	BSPT 1/8"	33/100	23	L-5.5	21	10	22	11	6	1
	100.08-150 R10	BSPT 1/8"	100/150	23	L-5.5	21	10	22	11	6	1
	100.08-200 R10	BSPT 1/8"	150/200	23	L-5.5	21	10	22	11	6	1
100.08 NPT	100.08-100 T10	NPT 1/8"	33/100	23	L-5.5	21	10	22	11	6	1
	100.08-150 T10	NPT 1/8"	100/150	23	L-5.5	21	10	22	11	6	1
	100.08-200 T10	NPT 1/8"	150/200	23	L-5.5	21	10	22	11	6	1
100.08 BSPT	100.08-100 R13	BSPT 1/4"	33/100	23	L-7.5	21	13.5	22	14	8	3
	100.08-150 R13	BSPT 1/4"	100/150	23	L-7.5	21	13.5	22	14	8	3
	100.08-200 R13	BSPT 1/4"	150/200	23	L-7.5	21	13.5	22	14	8	3
100.08 NPT	100.08-100 T13	NPT 1/4"	33/100	23	L-7.5	21	13.5	22	14	8	1
	100.08-150 T13	NPT 1/4"	100/150	23	L-7.5	21	13.5	22	14	8	1
	100.08-200 T13	NPT 1/4"	150/200	23	L-7.5	21	13.5	22	14	8	1
100.12 BSPT	100.12-100 R17	BSPT 3/8"	56/100	43	L-8.5	32	17	33	18	12	3
	100.12-150 R17	BSPT 3/8"	100/150	43	L-8.5	32	17	33	18	12	3
	100.12-200 R17	BSPT 3/8"	150/200	43	L-8.5	32	17	33	18	12	3
100.12 NPT	100.12-100 T17	NPT 3/8"	56/100	43	L-8.5	32	17	33	18	12	3
	100.12-150 T17	NPT 3/8"	100/150	43	L-8.5	32	17	33	18	12	3
	100.12-200 T17	NPT 3/8"	150/200	43	L-8.5	32	17	33	18	12	3
100.12 BSPT	100.12-100 R21	BSPT 1/2"	56/100	45	L-11.5	32	21	33	22	14	5
	100.12-150 R21	BSPT 1/2"	100/150	45	L-11.5	32	21	33	22	14	5
	100.12-200 R21	BSPT 1/2"	150/200	45	L-11.5	32	21	33	22	14	5
100.12 NPT	100.12-100 T21	NPT 1/2"	56/100	45	L-11.5	32	21	33	22	14	5
	100.12-150 T21	NPT 1/2"	100/150	45	L-11.5	32	21	33	22	14	5
	100.12-200 T21	NPT 1/2"	150/200	45	L-11.5	32	21	33	22	14	5
	100.12-250 T21	NPT 1/2"	200/250	45	L-11.5	32	21	33	22	14	5

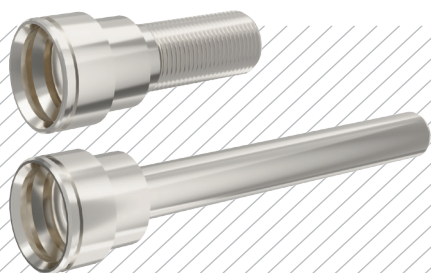

MOULD COOLING COUPLINGS
KÜHLUNGSELEMENTE FÜR WERKZEUGE

SERIE 100

EXTENSION COUPLINGS WITHOUT THREAD VERLÄNGERUNGSMUFFE OHNE GEWINDE

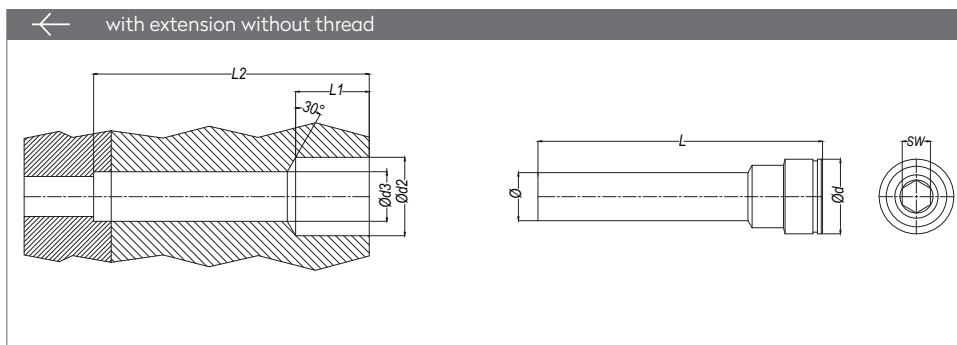

Serie	Part No.	Ø	L	L1	L2	Ød	Ød2	Ød3	SW
100.08	100.08-10 BU 50	10	50	23	L-5.5	21	22	11	6
	100.08-10 BU 100	10	100	23	L-5.5	21	22	11	6
	100.08-10 BU 150	10	150	23	L-5.5	21	22	11	6
	100.08-10 BU 200	10	200	23	L-5.5	21	22	11	6
100.08	100.08-13 BU 50	13.5	50	23	L-7.5	21	22	14	8
	100.08-13 BU 100	13.5	100	23	L-7.5	21	22	14	8
	100.08-13 BU 150	13.5	150	23	L-7.5	21	22	14	8
	100.08-13 BU 200	13.5	200	23	L-7.5	21	22	14	8
	100.08-13 BU 250	13.5	250	23	L-7.5	21	22	14	8
100.12	100.12-17 BU 50	17	50	43	L-8.5	32	33	18	12
	100.12-17 BU 100	17	100	43	L-8.5	32	33	18	12
	100.12-17 BU 150	17	150	43	L-8.5	32	33	18	12
	100.12-17 BU 200	17	200	43	L-8.5	32	33	18	12
	100.12-17 BU 250	17	250	43	L-8.5	32	33	18	12
100.12	100.12-21 BU 50	21	50	45	L-11.5	32	33	22	14
	100.12-21 BU 100	21	100	45	L-11.5	32	33	22	14
	100.12-21 BU 150	21	150	45	L-11.5	32	33	22	14
	100.12-21 BU 200	21	200	45	L-11.5	32	33	22	14
	100.12-21 BU 250	21	250	45	L-11.5	32	33	22	14

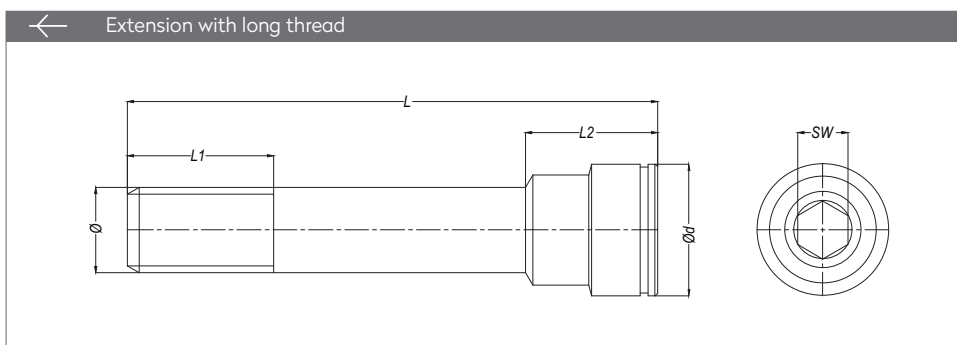

Serie	Part No.	Ø	L	L1	L2	Ød	SW
100.08	100.08-50 RF 10	BSP 1/8"	50	26	21	21	6
	100.08-100 RF 10	BSP 1/8"	100	60	21	21	6
	100.08-150 RF 10	BSP 1/8"	150	60	21	21	6
100.08	100.08-50 RF 13	BSP 1/4"	50	26.5	21	21	8
	100.08-100 RF 13	BSP 1/4"	100	60	21	21	8
	100.08-150 RF 13	BSP 1/4"	150	60	21	21	8
	100.08-200 RF 13	BSP 1/4"	200	60	21	21	8

MOULD COOLING COUPLINGS
KÜHLUNGSELEMENTE FÜR WERKZEUGE

SERIE 100



EXTENSION COUPLINGS VERLÄNGERUNGSMUFFE

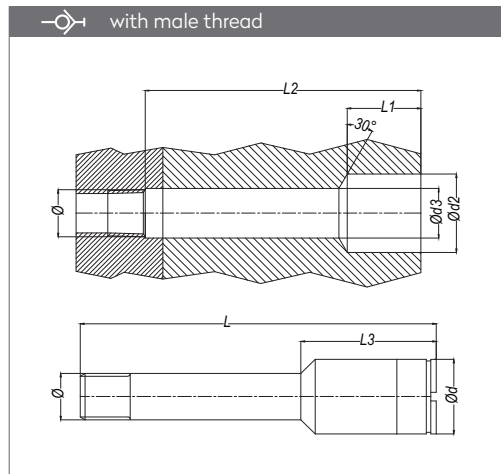

Serie	Part No.	Ø	Ød	Ød2	Ød3	L	L1	L2	L3
100.08	100.08-50 EUB10	BSP 1/8"	21	22	11	50	32	L-5.5	38
	100.08-100 EUB10	BSP 1/8"	21	22	11	100	32	L-5.5	38
	100.08-150 EUB10	BSP 1/8"	21	22	11	150	32	L-5.5	38
100.08	100.08-50 RUB10	BSPT 1/8"	21	22	11	50	32	L-5.5	38
	100.08-100 RUB10	BSPT 1/8"	21	22	11	100	32	L-5.5	38
	100.08-150 RUB10	BSPT 1/8"	21	22	11	150	32	L-5.5	38
100.08	100.08-50 EUB13	BSP 1/4"	21	22	14	50	32	L-7.5	38
	100.08-100 EUB13	BSP 1/4"	21	22	14	100	32	L-7.5	38
	100.08-150 EUB13	BSP 1/4"	21	22	14	150	32	L-7.5	38
	100.08-200 EUB13	BSP 1/4"	21	22	14	200	32	L-7.5	38
100.08	100.08-50 RUB13	BSPT 1/4"	21	22	14	50	32	L-7.5	38
	100.08-100 RUB13	BSPT 1/4"	21	22	14	100	32	L-7.5	38
	100.08-150 RUB13	BSPT 1/4"	21	22	14	150	32	L-7.5	38
	100.08-200 RUB13	BSPT 1/4"	21	22	14	200	32	L-7.5	38

CONNECTION SIZE ANSCHLUSSGRÖßEN

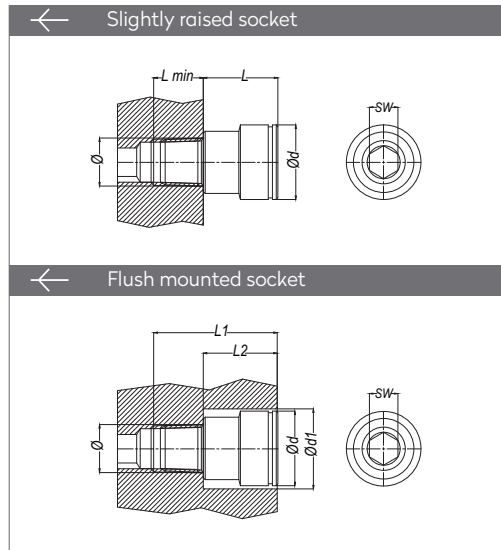

Serie	Ø	Slightly raised socket			Flush mounted socket				Torque Drehmoment (N.m)
		Ø	Ød	L _{min}	Ød1 _{min}	L2	L1	SW	
100.06	BSP 1/8"	17	20	10	18.5	20.5	29.5	6	15
	BSP 1/4"	17	18	13	18.5	18.5	30.5	6	30
	NPT 1/8"	17	22	10	18.5	22.5	31.5	1/4"	15
	NPT 1/4"	17	20	13.5	18.5	20.5	33	1/4"	30
100.08	BSP 1/8"	21	23	10	22.5	24	33	6	15
	BSP 1/4"	21	22	12	22.5	23	34	8	30
	BSP 3/8"	21	12	13	22.5	13	25	8	30
100.08	NPT 1/8"	21	25.5	10	22.5	25.5	35	1/4"	15
	NPT 1/4"	21	24	12	22.5	23.5	35.5	5/16"	30
	NPT 3/8"	21	14	13	22.5	14	27	5/16"	30
100.12	BSP 3/8"	32	29	13	33.5	30	42	10	50
	BSP 1/2"	32	30	15	33.5	31	45	14	50
	BSP 3/4"	32	15	18	33.5	20	36	14	50
	NPT 3/8"	32	33	13	33.5	33	46	3/8"	50
	NPT 1/2"	32	35	15	33.5	34.5	51	9/16"	50
	NPT 3/4"	32	17.5	18	33.5	17.5	36.5	9/16"	50

ACCESSORIES ZUBEHÖR

Water Drain Gun From the Injection Machine

Serie	Part No.
100-08	TSM 100-08
100-12	TSM 100-12

Water Drain Gun From the Mould

Serie	Part No.
100-08	TS 100-08
100-12	TS 100-12

Colour identification Rings for Plugs Markierungsringe für Stecknippel

	Serie	Part no. / Blue	Part no. / Red
	100.06	KDH-2100-1600-45B	KDH-2100-1600-45R
	100.08	KDH-2550-2000-40B	KDH-2550-2000-40R
	100.12	KDH-3600-3000-40B	KDH-3600-3000-40R

Colour identification collar for hoses Markierungsringe für Schlauch

	Part no. / Blue	Part no. / Red	Hose Outer Dia.
	BH 13	RH 13	Ø 13 to 17 mm
	BH 17	RH 17	Ø 17 to 24 mm
	BH 24	RH 24	Ø 24 to 28 mm

MOULD COOLING COUPLINGS

KÜHLUNGSELEMENTE FÜR WERKZEUGE

DN 6-16

SERIE 101

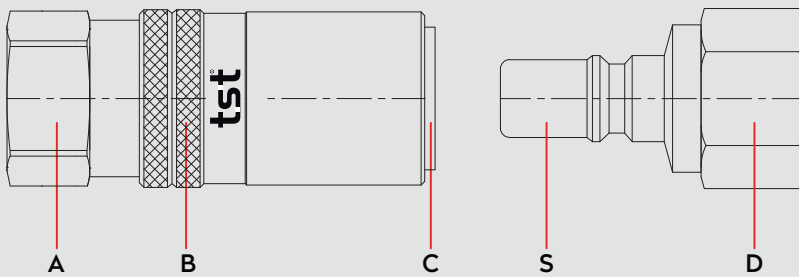
Materials

Material Code

A = Brass

B = AISI 420 - Chrome Plated

C = Brass

S = Brass Nickel Plated

* Serie 101.16 → AISI420

D = Brass Nickel Plated



0 - 16 bar



-26°C to + 200°C (FPM)

Shut Off Type

COUPLING

TST 101.06	TST 101.09	TST 101.12	TST 101.16
OV 200 - 00800	OV 262 - 01235	OV 280 - 01600	OV 262 - 02105
OV 120 - 00900	OV 100 - 01300	OV 262 - 01075	OV 262 - 01510
OV 200 - 00450	OV 200 - 00800	OV 157 - 01600	OV 200 - 02000

PLUG

TST 101.06	TST 101.09	TST 101.12	TST 101.16
OV 178 - 00290	OV 200 - 00600	OV 205 - 00870	OV 262 - 01235
OV 178 - 01110	OV 140 - 01500	OV 157 - 01950	OV 157 - 02700

DN

TST 101.06 → 6mm
 TST 101.09 → 9mm
 TST 101.12 → 12mm
 TST 101.16 → 16mm

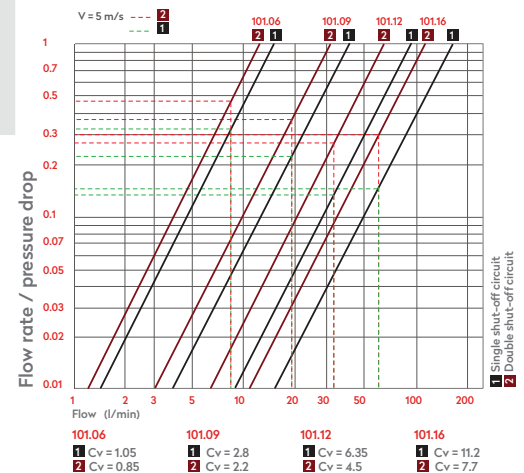
Options

E2

 FFKM
 please ask

 HT
 101.09 - 101.16

NICKEL

EPDM

 AISI303
 Stainless Steel

 Id.
 Ring

Applications

- Cold - hot fluid circuits
- Temperature control

Compatible with

PARKER 6006-6009-6012-6016

MOULD COOLING COUPLINGS
KÜHLUNGSELEMENTE FÜR WERKZEUGE

SERIE 101



QUICK COUPLINGS SCHNELLKUPPLUNGEN

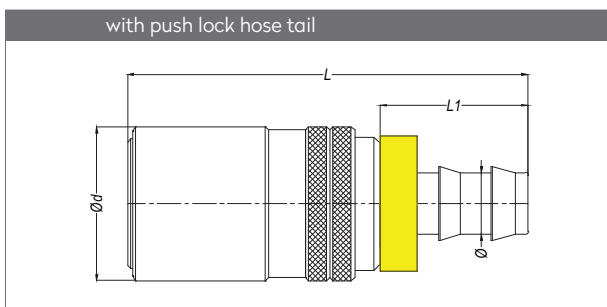
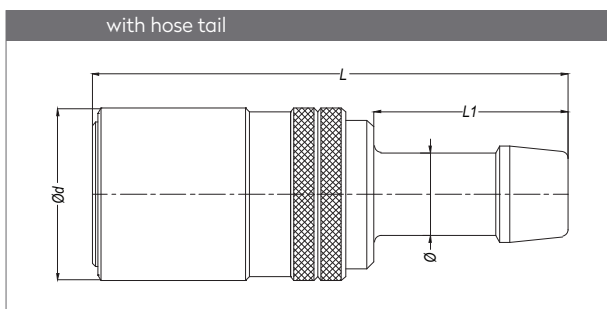
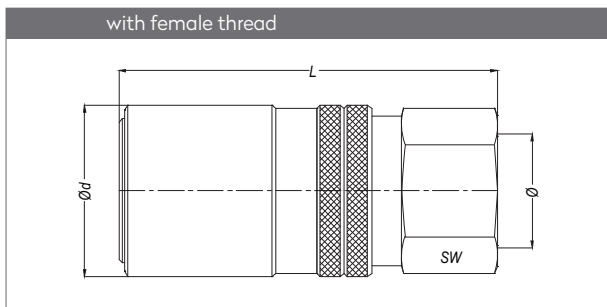
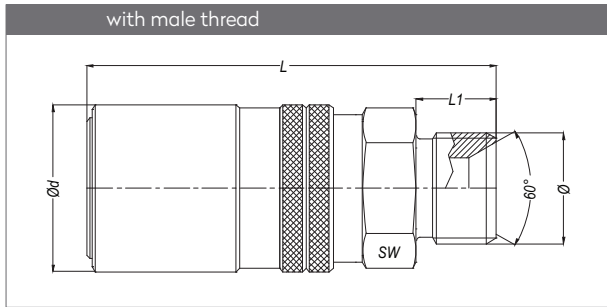

Part no.		DN	Ø	Ød	L	L1	SW
101.06 EGB 13	101.06 EGF 13	6	BSP 1/4"	19.3	51.4	9	17
101.09 EGB 17	101.09 EGF 17	9	BSP 3/8"	25	61.2	12	22
101.12 EGB 21	101.12 EGF 21	12	BSP 1/2"	30.3	72	14	27
101.16 EGB 26	101.16 EGF 26	16	BSP 3/4"	38	95	18	35

Part no.		DN	Ø	Ød	L	SW
101.06 DGB 13	101.06 DGF 13	6	BSP 1/4"	19.3	45.4	17
101.06 NGB 13	101.06 NGF 13	6	NPT 1/4"	19.3	45.4	17
101.09 DGB 17	101.09 DGF 17	9	BSP 3/8"	25	53.2	22
101.09 NGB 17	101.09 NGF 17	9	NPT 3/8"	25	53.2	22
101.12 DGB 21	101.12 DGF 21	12	BSP 1/2"	30.3	67	27
101.12 NGB 21	101.12 NGF 21	12	NPT 1/2"	30.3	65	27
101.16 DGB 26	101.16 DGF 26	16	BSP 3/4"	38	90	35
101.16 NGB 26	101.16 NGF 26	16	NPT 3/4"	38	90	35

Part no.		DN	Ø	Ød	L	L1
101.06 HGB 08	101.06 HGF 08	6	08 - 5/16"	19.3	59.4	23
101.09 HGB 12	101.09 HGF 12	9	12 - 15/32"	25	69.2	28.3
101.12 HGB 13	101.12 HGF 13	12	13 - 1/2"	30.3	81.1	28
101.12 HGB 16	101.12 HGF 16	12	16 - 5/8"	30.3	81.1	28
101.16 HGB 16	101.16 HGF 16	16	16 - 5/8"	38	108	28
101.16 HGB 19	101.16 HGF 19	16	19 - 3/4"	38	108	28

Part no.		DN	Ø	Ød	L	L1
101.06 FGB 10	101.06 FGF 10	6	10 - 3/8"	19.7	60.4	24
101.09 FGB 10	101.09 FGF 10	9	10 - 3/8"	25	66.2	24
101.09 FGB 13	101.09 FGF 13	9	13 - 1/2"	25	69.7	28
101.12 FGB 13	101.12 FGF 13	12	13 - 1/2"	30.3	81.1	28
101.16 FGB 16	101.16 FGF 16	16	16 - 5/8"	38	113	38
101.16 FGB 19	101.16 FGF 19	16	19 - 3/4"	38	113	38

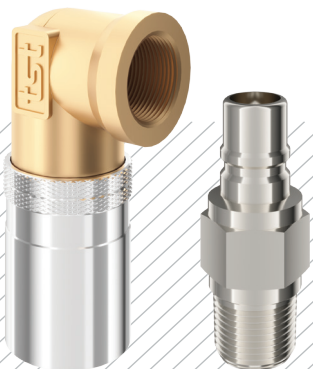
 MOULD COOLING COUPLINGS
 KÜHLUNGSELEMENTE FÜR WERKZEUGE

SERIE 101

QUICK COUPLINGS SCHNELLKUPPLUNGEN

with female thread 45°

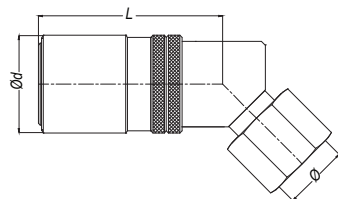

Part no.		DN	Ø	Ød	L
101.06 DGB 13-45°	101.06 DGF 13-45°	6	BSP 1/4"	19.3	40
101.09 DGB 17-45°	101.09 DGF 17-45°	9	BSP 3/8"	25	47.3

with hose tail 45°

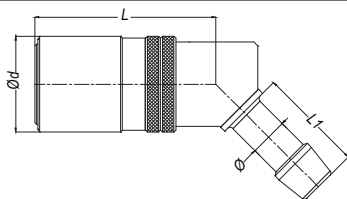

Part no.		DN	Ø	Ød	L	L1
101.06 HGB 08-45°	101.06 HGF 08-45°	6	08-5/16"	19.3	40	23
101.09 HGB 10-45°	101.09 HGF 10-45°	9	10-3/8"	25	47.3	27.5
101.09 HGB 12-45°	101.09 HGF 12-45°	9	12-15/32"	25	47.3	27.5

with male thread 90°

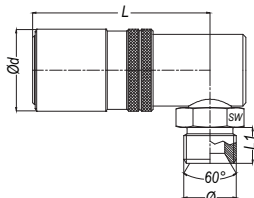

Part no.		DN	Ø	Ød	L	L1	SW
101.06 EGB 13-90°	101.06 EGF 13-90°	6	BSP 1/4"	19.3	51	9	17
101.09 EGB 17-90°	101.09 EGF 17-90°	9	BSP 3/8"	25	54.3	9	22
101.12 EGB 21-90°	101.12 EGF 21-90°	12	BSP 1/2"	30.3	64.6	12	27
101.16 EGB 26-90°	101.16 EGF 26-90°	16	BSP 3/4"	38	71.5	18	32

with female thread 90°

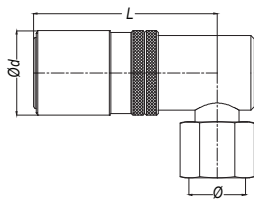

Part no.		DN	Ø	Ød	L
101.06 DGB 13-90°	101.06 DGF 13-90°	6	BSP 1/4"	19.3	51
101.06 NGB 13-90°	101.06 NGF 13-90°	6	NPT 1/4"	19.3	51
101.09 DGB 17-90°	101.09 DGF 17-90°	9	BSP 3/8"	25	54.3
101.09 NGB 17-90°	101.09 NGF 17-90°	9	NPT 3/8"	25	54.3
101.12 DGB 21-90°	101.12 DGF 21-90°	12	BSP 1/2"	37.3	64.6
101.12 NGB 21-90°	101.12 NGF 21-90°	12	NPT 1/2"	37.3	64.6

with hose tail 90°

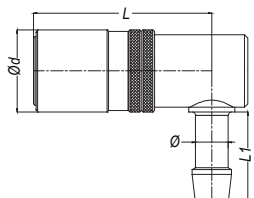

Part no.		DN	Ø	Ød	L	L1
101.06 HGB 08-90°	101.06 HGF 08-90°	6	08 - 5/16"	19.3	51	23
101.09 HGB 10-90°	101.09 HGF 10-90°	9	10 - 3/8"	25	54.3	27.5
101.09 HGB 12-90°	101.09 HGF 12-90°	9	12 - 15/32"	25	54.3	27.5
101.12 HGB 16-90°	101.12 HGF 16-90°	12	16 - 5/8"	30.3	64.6	27.5
101.16 HGB 19-90°	101.16 HGF 19-90°	16	19 - 3/4"	38	71.5	53

MOULD COOLING COUPLINGS
KÜHLUNGSELEMENTE FÜR WERKZEUGE

SERIE 101



PLUGS STECKNIPPEL

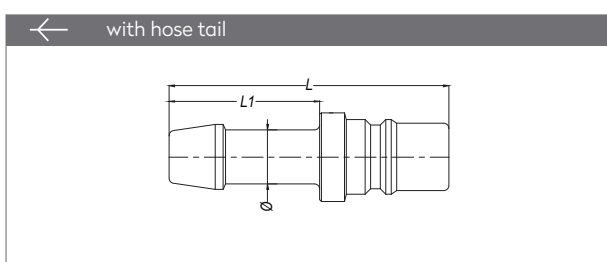
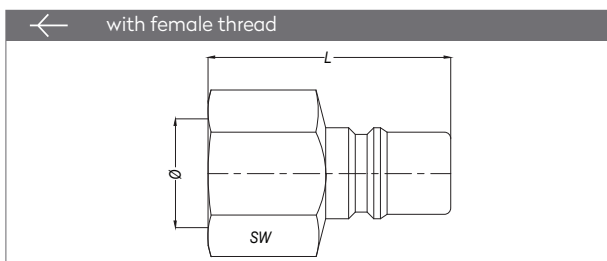
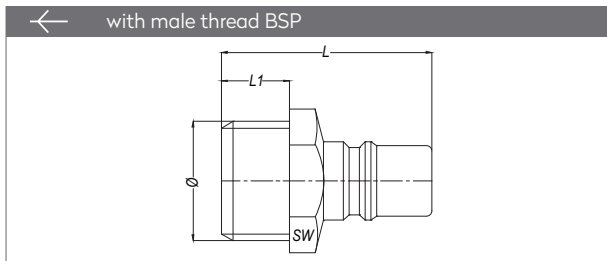
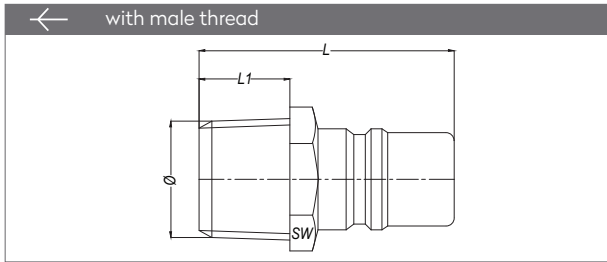
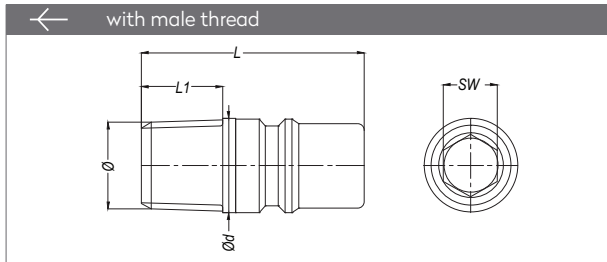

Part no.	DN	Ø	L	L1	Ød	SW
101.06 RU 10	6	BSPT 1/8"	30	9	10	5
101.06 RU 13	6	BSPT 1/4"	33	11	14	5
101.06 TU 10	6	NPT 1/8"	34	12	10	5
101.06 TU 13	6	NPT 1/4"	34	12	14	5
101.09 RU 13	9	BSPT 1/4"	33	12	14	8
101.09 RU 17	9	BSPT 3/8"	36	13	17	8
101.09 TU 13	9	NPT 1/4"	36	13	14	8
101.09 TU 17	9	NPT 3/8"	36	13	17	8
101.12 RU 17	12	BSPT 3/8"	39	13	18	10
101.12 TU 17	12	NPT 3/8"	39	13	18	10

Part no.	DN	Ø	L	L1	SW
101.12 RU 21	12	BSPT 1/2"	45	16	22
101.12 TU 21	12	NPT 1/2"	46	17	22
101.16 RU 21	16	BSPT 1/2"	56	17	22
101.16 RU 26	16	BSPT 3/4"	59.5	18	24

Part no.	DN	Ø	L	L1	SW
101.06 EU 10	6	BSP 1/8"	30.8	7	14
101.06 EU 13	6	BSP 1/4"	32.8	9	14
101.09 EU 21	9	BSP 1/2"	37	12	22
101.12 EU 26	12	BSP 3/4"	46	16	27
101.16 EUM 24	16	M24x1.5	39	15	30

Part no.	DN	Ø	L	SW
101.06 DU 13	6	BSP 1/4"	34	17
101.06 NU 13	6	NPT 1/4"	36	17
101.09 DU 17	9	BSP 3/8"	37	22
101.09 NU 17	9	NPT 3/8"	37	22
101.12 DU 21	12	BSP 1/2"	45	27
101.12 NU 21	12	NPT 1/2"	46	27
101.16 DU 26	16	BSP 3/4"	58	32
101.16 NU 26	16	NPT 3/4"	60	32

Part no.	DN	Ø	L	L1
101.06 HU 08	6	Ø8 5/16"	44	23
101.09 HU 12	9	Ø12 15/32"	53	28
101.12 HU 16	12	Ø16 5/8"	59	33
101.16 HU 19	16	Ø19 3/4"	70	33

 MOULD COOLING COUPLINGS
 KÜHLUNGSELEMENTE FÜR WERKZEUGE

SERIE 101

VALVED PLUGS VERSCHLUSSNIPPEL

with male thread + o'ring

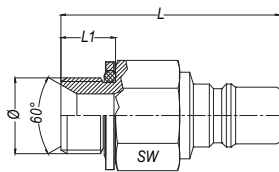

* without KS

with male thread

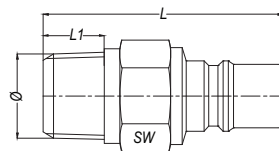

with male thread BSP

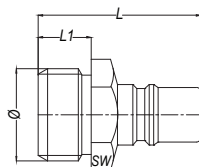

with female thread

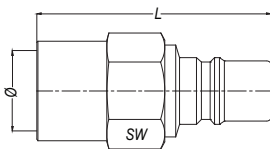

Flexible Diverting connector

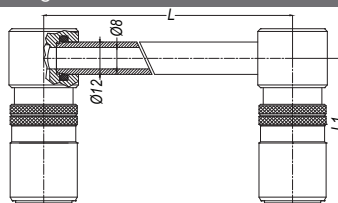

Part No.	L	L1
101.09 KG 125	125	54.5
101.09 KG 500	500	54.5
101.09 KG 1000	1000	54.5

Part no.	DN	Ø	L	L1	SW
101.06 OUB 10	6	BSP 1/8"	43.8	9	17
101.06 OUB 13	6	BSP 1/4"	41.8	9	17
101.09 OUB 13	9	BSP 1/4"	49	9	19
101.09 OUB 17	9	BSP 3/8"	48	10	20
101.12 OUB 17*	12	BSP 3/8"	60	9	24
101.12 OUB 21*	12	BSP 1/2"	62	11	27
101.16 OUB 26*	16	BSP 3/4"	65	16	32

Part no.	DN	Ø	L	L1	SW
101.06 RUB 10	6	BSPT 1/8"	45.8	10	17
101.06 RUB 13	6	BSPT 1/4"	44.8	12	17
101.06 TUB 10	6	NPT 1/8"	44.8	11	17
101.06 TUB 13	6	NPT 1/4"	45.8	13	17
101.09 RUB 13	9	BSPT 1/4"	48.5	12	19
101.09 RUB 17	9	BSPT 3/8"	47	12	19
101.09 TUB 13	9	NPT 1/4"	46	11	19
101.09 TUB 17	9	NPT 3/8"	47	12	19
101.12 RUB 17	12	BSPT 3/8"	63	13	24
101.12 RUB 21	12	BSPT 1/2"	64.5	17	24
101.12 TUB 17	12	NPT 3/8"	63	13	24
101.12 TUB 21	12	NPT 1/2"	64.5	17	24
101.16 RUB 26	16	BSPT 3/4"	83	21	32
101.16 TUB 26	16	NPT 3/4"	83	21	32

Part no.	DN	Ø	L	L1	SW
101.06 EUB 17	6	BSP 3/8"	35	9	19
101.09 EUB 21	9	BSP 1/2"	37	12	22
101.12 EUB 26	12	BSP 3/4"	46	16	27
101.16 EUB 33	16	BSP 1"	60	22	32

Part no.	DN	Ø	L	SW
101.06 DUB 13	6	BSP 1/4"	48.5	17
101.06 NUB 13	6	NPT 1/4"	47.8	17
101.09 DUB 13	9	BSP 1/4"	48.5	19
101.09 NUB 13	9	NPT 1/4"	48.5	19
101.09 DUB 17	9	BSP 3/8"	48.5	21
101.12 NUB 21	12	NPT 1/2"	63	27
101.16 DUB 26	16	BSP 3/4"	81	32
101.16 NUB 26	16	NPT 3/4"	81	32

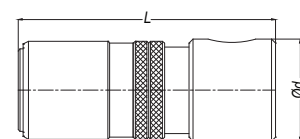

Part No.	Ød	L
101.09 KG 00	26	65.5

Part No. for the brass tube	Outer Ød	Thickness
101.09 KPB x Length	12	2

MOULD COOLING COUPLINGS
KÜHLUNGSELEMENTE FÜR WERKZEUGE

SERIE 101



INSTALLATION

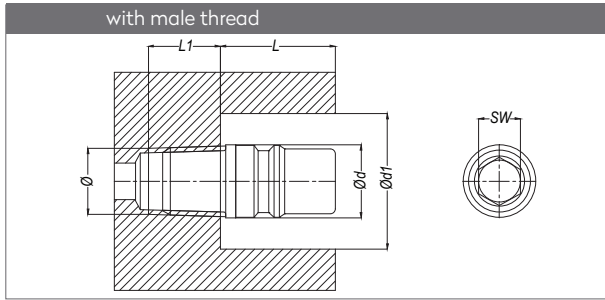

Part no.	Ø	DN	Ød	Ød1	L	L1	SW
101.06 RU 10	BSPT 1/8"	6	10	20	26	9	5
101.06 TU 10	NPT 1/8"	6	11	20	28	9	5
101.06 RU 13	BSPT 1/4"	6	14	20	27	11	5
101.06 TU 13	NPT 1/4"	6	14	20	27	12	5
101.09 RU 13	BSPT 1/4"	9	14	26	26	12	8
101.09 TU 13	NPT 1/4"	9	14	26	28	13	8
101.09 RU 17	BSPT 3/8"	9	17	26	28	13	8
101.09 TU 17	NPT 3/8"	9	17	26	28	13	8
101.12 RU 17	BSPT 3/8"	12	18	33	31	13	10

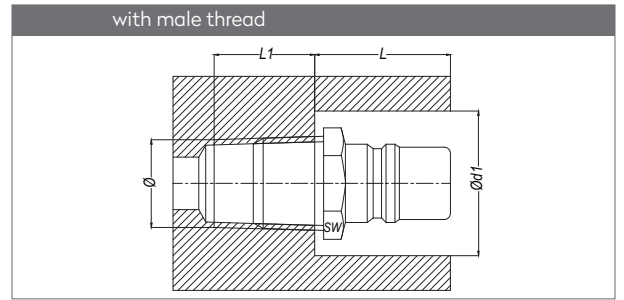

Part no.	Ø	DN	Ød1	L	L1	SW
101.12 TU 17	NPT 3/8"	12	33	31	13	10
101.12 RU 21	BSPT 1/2"	12	33	34	16	22
101.12 TU 21	NPT 1/2"	12	33	34	17	22
101.16 RU 26	BSPT 3/4"	16	40	46	18	27

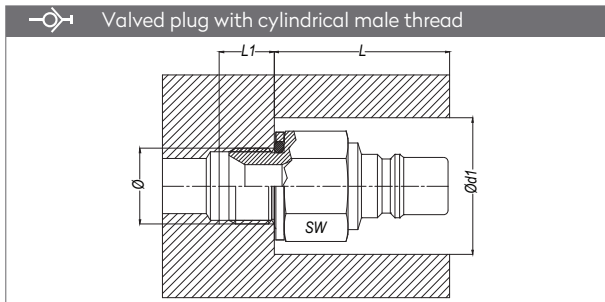

Part no.	Ø	DN	Ød1	L	L1	SW
101.06 EUB 10	BSP 1/8"	6	36	24	8	17
101.06 EUB 13	BSP 1/4"	6	33	27	9	17
101.09 EUB 13	BSP 1/4"	9	36	29	9	19
101.09 EUB 17	BSP 3/8"	9	36	30	12	19
101.12 EUB 17	BSP 3/8"	12	50	36	9	24
101.12 EUB 21	BSP 1/2"	12	50	36	12	24
101.16 EUB 26	BSP 3/4"	16	64	46	16	32

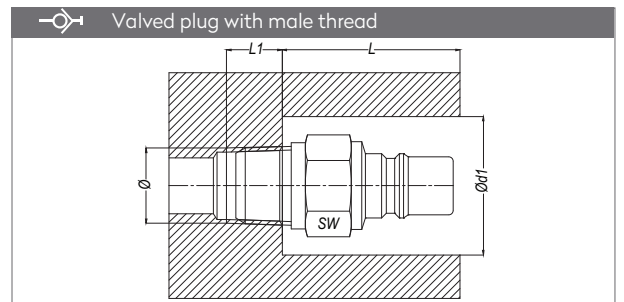

Part no.	Ø	DN	Ød1	L	L1	SW
101.06 RUB 10	BSPT 1/8"	6	27	36	10	17
101.06 TUB 10	NPT 1/8"	6	27	36	9	17
101.06 RUB 13	BSPT 1/4"	6	27	33	12	17
101.06 TUB 13	NPT 1/4"	6	27	33	13	17
101.09 RUB 13	BSPT 1/4"	9	29	36.5	12	19
101.09 TUB 13	NPT 1/4"	9	29	35	11	19
101.09 RUB 17	BSPT 3/8"	9	29	35	12	19
101.09 TUB 17	NPT 3/8"	9	29	35	12	19
101.12 RUB 17	BSPT 3/8"	12	36	50	13	24
101.12 TUB 17	NPT 3/8"	12	36	50	13	24
101.12 RUB 21	BSPT 1/2"	12	36	48	17	24
101.12 TUB 21	NPT 1/2"	12	36	48	17	24
101.16 RUB 26	BSPT 3/4"	16	46	62	21	32
101.16 TUB 26	NPT 3/4"	16	46	62	21	32

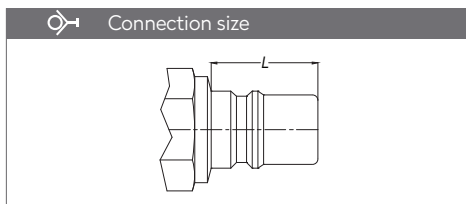

Part no.	DN	L
101.06	6	17.8
101.09	9	19
101.12	12	24
101.16	16	31



DN 20-38

MOULD COOLING COUPLINGS
KÜHLUNGSELEMENTE FÜR WERKZEUGE

SERIE 101

Materials

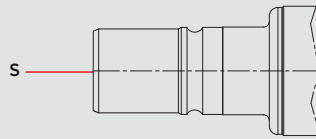
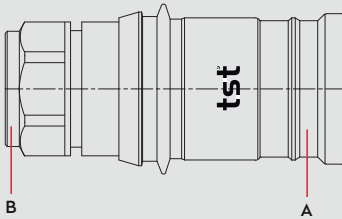

Material Code

A = AISI 420 / Chrome Plated

B = Brass Nickel Plated

S = AISI 420 / Chrome Plated



0 - 16 bar



-26° to + 200°C (FPM)

Shut Off Type

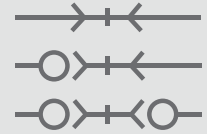

COUPLING

101.20

OV 353 - 02975
OV 262 - 03140
OV 300 - 02000

101.25

OV 353 - 03490
OV 262 - 03690
OV 353 - 02180-88

101.38

OV 353 - 04605
OV 262 - 06000
OV 353 - 03810

PLUG

101.20

OV 262 - 01785
OV 262 - 03540

101.25

OV 353 - 01865
OV 262 - 03690

101.38

OV 353 - 03295
OV 262 - 06000

DN

TST 101.20 → 20 mm

TST 101.25 → 25 mm

TST 101.38 → 38 mm

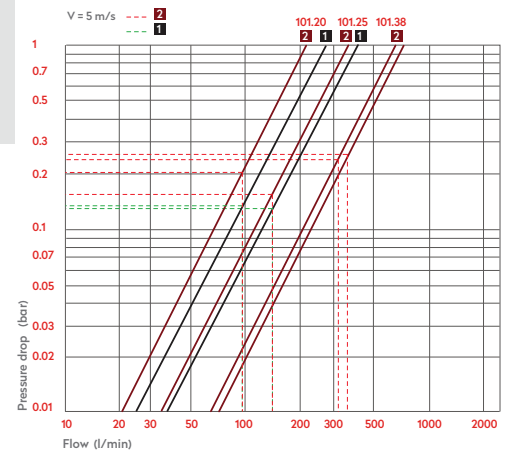

Options

E2

FFKM
please ask



EPDM

Id.
Ring

Applications

- Cold - hot fluid circuits
- Temperature control

Compatible with

MOULD COOLING COUPLINGS
KÜHLUNGSELEMENTE FÜR WERKZEUGE

SERIE 101



QUICK COUPLINGS SCHNELLKUPPLUNGEN

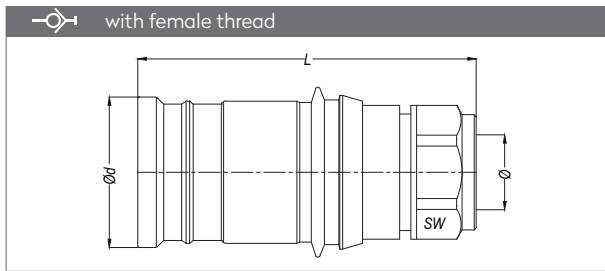

Part no.	Ø	DN	Ød	L	SW
101.20 DGB 26	BSP 3/4"	20	53	117	41
101.20 NGB 26	NPT 3/4"	20	53	117	41
101.20 DGB 33	BSP 1"	20	53	117	41
101.20 NGB 33	NPT 1"	20	53	117	41
101.25 DGB 33	BSP 1"	25	60	140.8	50
101.25 DGB 42	BSP 1 1/4"	25	60	140.8	50
101.38 DGB 48	BSP 1 1/2"	38	82.3	158.4	70
101.38 DGB 60	BSP 2"	38	82.3	168.4	75

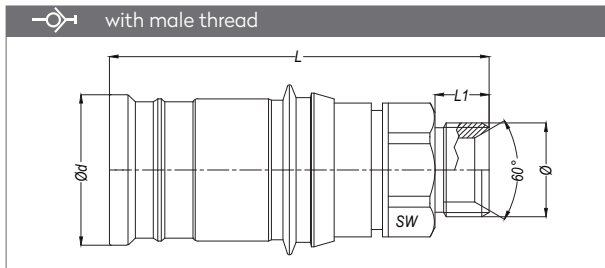

Part no.	Ø	DN	Ød	L	L1	SW
101.20 EGB 33	BSP 1"	20	53	131.5	19	41
101.25 EGB 33	BSP 1"	25	60	142	19	50
101.25 EGB 42	BSP 1 1/4"	25	60	144	22	50
101.38 EGB 48	BSP 1 1/2"	38	82.3	182	22	70
101.38 EGB 60	BSP 2"	38	82.3	184.4	25	70

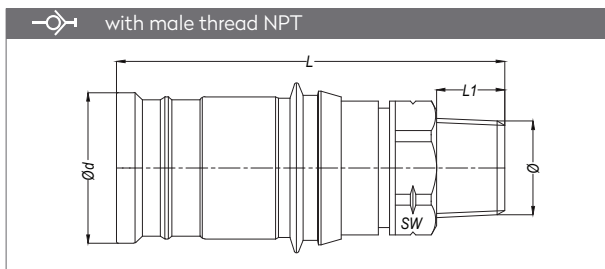

Part no.	Ø	DN	Ød	L	L1	SW
101.20 TGB 33	NPT 1"	20	53	133.5	21	41
101.25 TGB 33	NPT 1"	25	60	144	21	50
101.25 TGB 42	NPT 1 1/4"	25	60	147	15	50
101.38 TGB 48	NPT 1 1/2"	38	82.3	184	27	70
101.38 TGB 60	NPT 2"	38	82.3	190.4	31	70

 MOULD COOLING COUPLINGS
 KÜHLUNGSELEMENTE FÜR WERKZEUGE

SERIE 101

PLUGS STECKNIPPEL

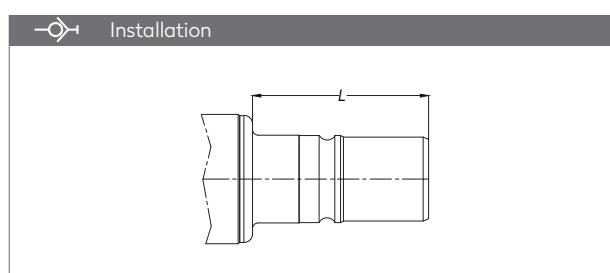
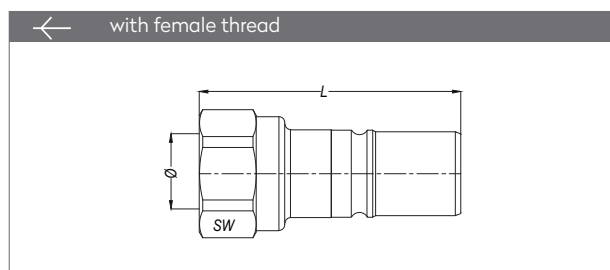
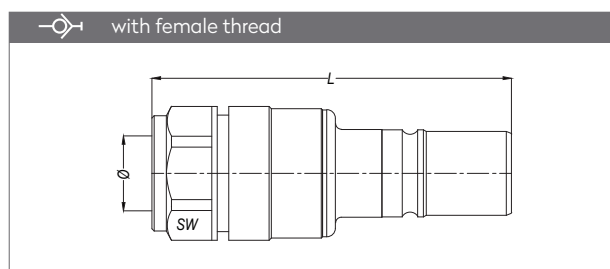
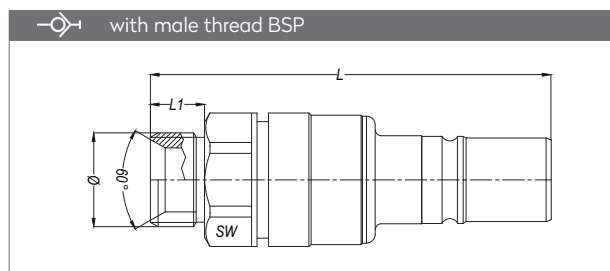
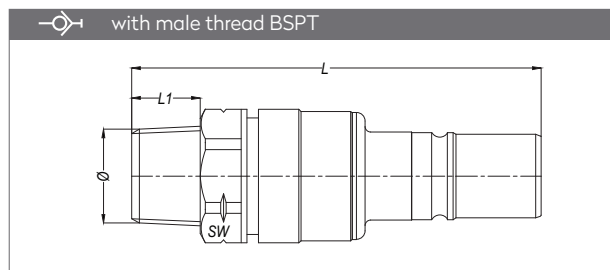

Part no.	Ø	DN	L	L1	SW
101.20 RUB 33	BSPT 1"	20	143	21	41
101.25 RUB 33	BSPT 1"	25	151.5	23	50
101.25 RUB 42	BSPT 1 1/4"	25	152.5	24	50
101.38 RUB 48	BSPT 1 1/2"	38	178	24	70
101.38 RUB 60	BSPT 2"	38	184	30	70

Part no.	Ø	DN	L	L1	SW
101.20 EUB 33	BSP 1"	20	141	19	41
101.25 EUB 33	BSP 1"	25	149.5	19	50
101.25 EUB 42	BSP 1 1/4"	25	152.5	22	50
101.38 EUB 48	BSP 1 1/2"	38	176	22	70
101.38 EUB 60	BSP 2"	38	179	25	70

Part no.	Ø	DN	L	SW
101.20 DUB 26	BSP 3/4"	20	126.5	41
101.20 DUB 33	BSP 1"	20	126.5	41
101.20 NUB 33	NPT 1"	20	126.5	41
101.25 DUB 33	BSP 1"	25	148.5	50
101.25 DUB 42	BSP 1 1/4"	25	148.5	50
101.38 DUB 48	BSP 1 1/2"	38	156	70
101.38 DUB 60	BSP 2"	38	165	75

Part no.	Ø	DN	L	SW
101.20 DU 33	BSP 1"	20	92	41
101.25 DU 33x100	BSP 1"	25	100	41
101.38 DU 48	BSP 1 1/2"	38	156	70

Part no.	DN	L
101.20	20	61
101.25	25	72
101.38	38	74.4



Materials

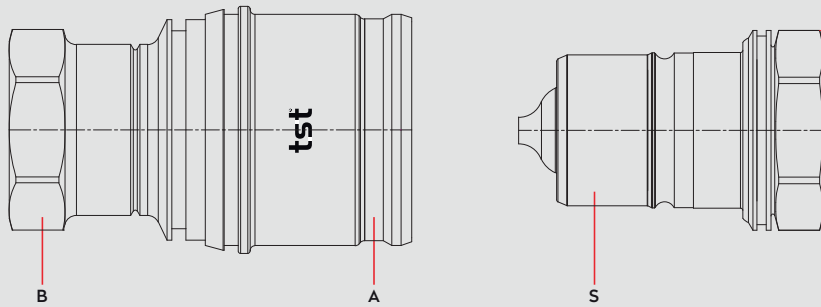

Material Code

A = AISI 316
B = Brass Chemical Nickel Plated
S = AISI 420

0 - 16 bar

-26° to + 200°C (FPM)

Shut Off Type

COUPLING
OV 353 - 03490
OV 353 - 06390

PLUG
OV 353 - 03490

DN 37 mm

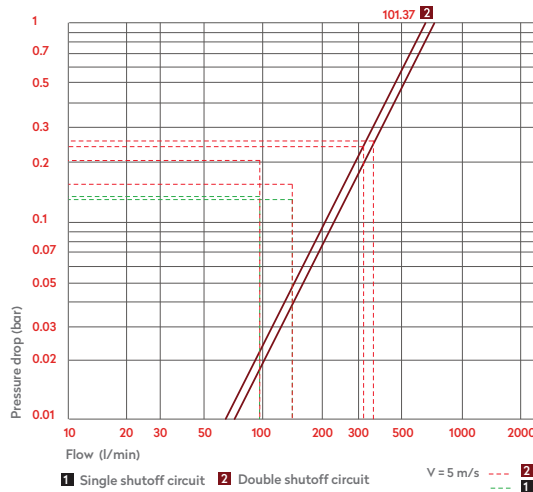

Options

E2

FFKM
please ask

EPDM

Id. Ring

Applications

- Cold - hot fluid circuits
- Temperature control

Compatible with



MOULD COOLING COUPLINGS
KÜHLUNGSELEMENTE FÜR WERKZEUGE

SERIE 101.37

QUICK COUPLINGS SCHNELLKUPPLUNGEN

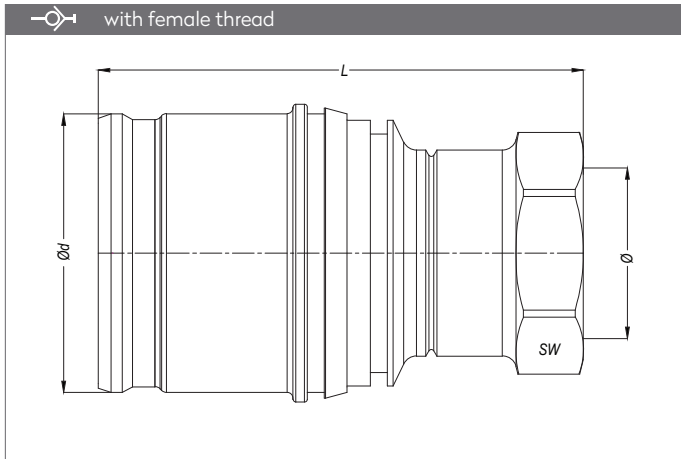

Part no.	Ø	DN	Ød	L	SW
101.37 DGB 60	BSP 2"	38	104.8	170.7	75

PLUGS STECKNIPPEL

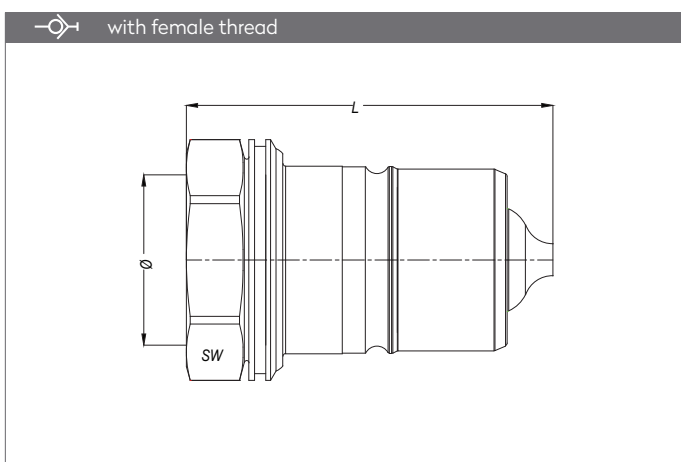

Part no.	Ø	DN	L	SW
101.37 DUB 60	BSP 2"	38	129	75

SERIE 102





DN 6-12

MOULD COOLING COUPLINGS
KÜHLUNGSELEMENTE FÜR WERKZEUGE

SERIE 102

Materials

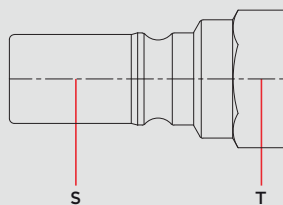
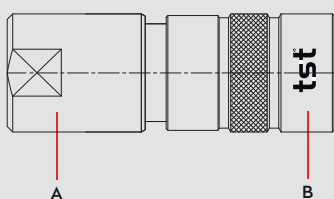

Material Code

- A = Brass
- B = AISI 420 / Chrome Plated
- S = AISI 420
- T = Brass



0 - 50 bar



-26° to + 200°C (FPM)

Shut Off Type



COUPLING

TST 102.06

OV 200 - 01200
OV 157 - 01500
OV 190 - 00370

TST 102.07

OV 178 - 01280
OV 157 - 01500
OV 190 - 00420

TST 102.09

OV 200 - 01700
OV 200 - 00650
OV 178 - 01875

TST 102.12

OV 262 - 02345
OV 262 - 00835 - 88
OV 262 - 02665 - 88

PLUG

TST 102.06
OV 190 - 00370
OV 178 - 01110

TST 102.07
OV 190 - 00420
OV 178 - 01110

TST 102.09
OV 200 - 00650
OV 178 - 01520

TST 102.12
OV 262 - 02025
OV 250 - 00800 - 88

DN

- TST 102.06 → 6 mm
- TST 102.07 → 7 mm
- TST 102.09 → 9 mm
- TST 102.12 → 12 mm

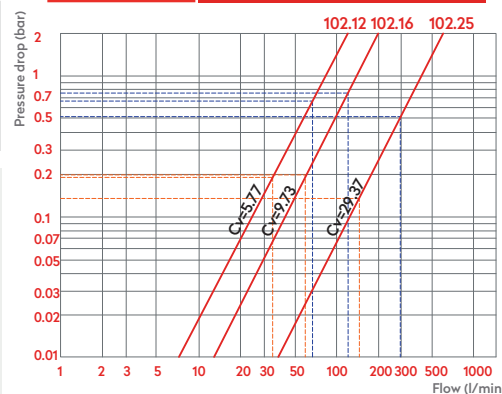

Options

EPDM

FFKM
please ask

E2

H4

Applications

- Blow Moulding
- Injection Moulding

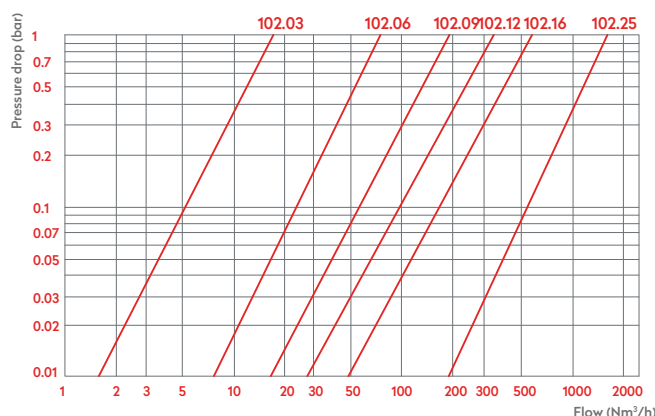
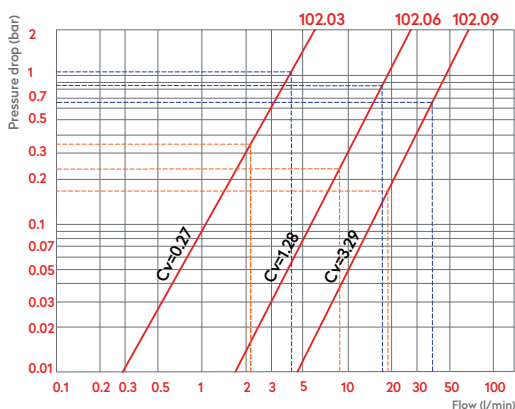

MOULD COOLING COUPLINGS
KÜHLUNGSELEMENTE FÜR WERKZEUGE

SERIE 102

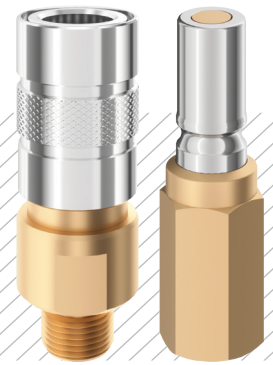

QUICK COUPLINGS SCHNELLKUPPLUNGEN

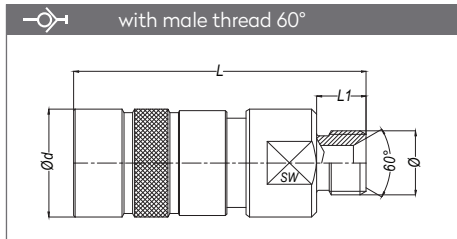

Part No.	DN	Ø	Ød	L	L1	SW
102.06 EGB 13	06	BSP 1/4"	21.8	59.2	10	20
102.07 EGB 13	07	BSP 1/4"	21.8	59.2	10	20
102.09 EGB 17	09	BSP 3/8"	28	77.5	12	24
102.12 EGB 21	12	BSP 1/2"	41.1	109.1	14	27

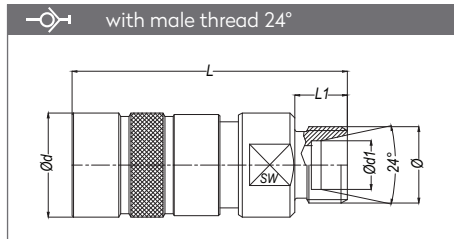

Part No.	DN	Ø	Ød	L	L1	SW
102.06 EGBM 16-10	06	M16x1.5	21.8	58	11	20
102.07 EGBM 16-10	07	M16x1.5	21.8	58	11	20
102.09 EGBM 18-12	09	M18x1.5	28	77.5	12	24
102.12 EGBM 22-12	12	M22x1.5	41	108.1	13	27

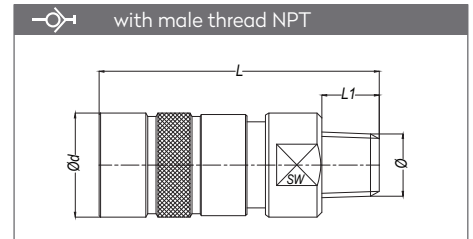

Part No.	DN	Ø	Ød	L	L1	SW
102.06 TGB 13	06	NPT 1/4"	21.8	62.2	13	20
102.07 TGB 13	07	NPT 1/4"	21.8	62.2	13	20
102.09 TGB 17	09	NPT 3/8"	28	78.5	13	24

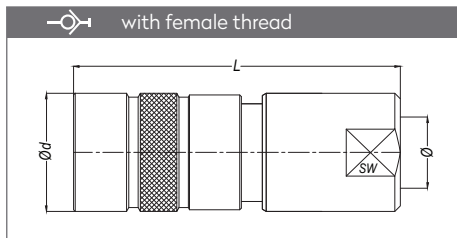

Part No.	DN	Ø	Ød	L	SW
102.06 DGB 13	06	21.8	BSP 1/4"	60.4	20
102.07 DGB 13	07	21.8	BSP 1/4"	60.4	20
102.09 DGB 17	09	28	BSP 3/8"	75.5	24
102.12 DGB 21	12	41	BSP 1/2"	102.9	27
102.06 NGB 13	06	21.8	NPT 1/4"	60.4	20
102.07 NGB 13	07	21.8	NPT 1/4"	60.4	20
102.09 NGB 17	09	28	NPT 3/8"	75.5	24
102.12 NGB 21	12	44	NPT 1/2"	102.9	27

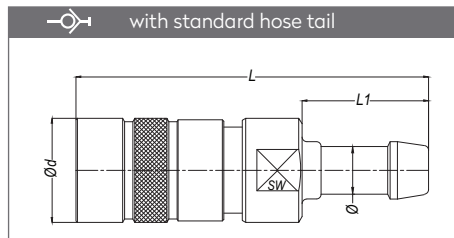

Part No.	DN	Ø	Ød	L	L1	SW
102.06 HGB 10	06	Ø10	21.8	73.9	26.5	20
102.07 HGB 10	07	Ø10	21.8	73.9	26.5	20
102.09 HGB 13	09	Ø13	28	93	27.5	24

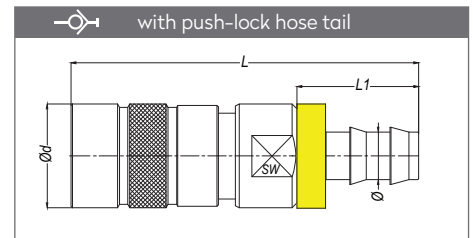

Part No.	DN	Ø	Ød	L	L1	SW
102.06 FGB 10	06	Ø10	21.7	73.4	26	20
102.07 FGB 10	07	Ø10	21.7	73.4	26	20
102.09 FGB 13	09	Ø13	28	93.5	28	24
102.12 FGB 16	12	Ø16	41	124.9	28	36

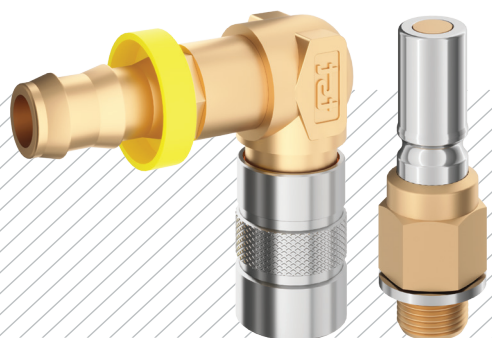

 MOULD COOLING COUPLINGS
 KÜHLUNGSELEMENTE FÜR WERKZEUGE

SERIE 102

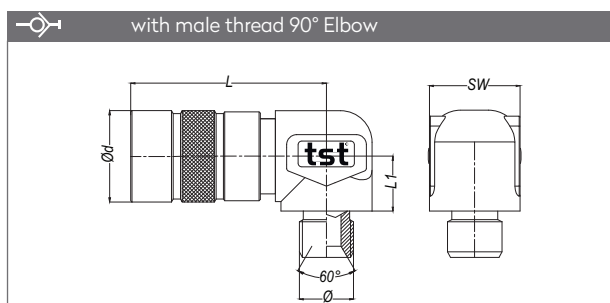
QUICK COUPLINGS SCHNELLKUPPLUNGEN

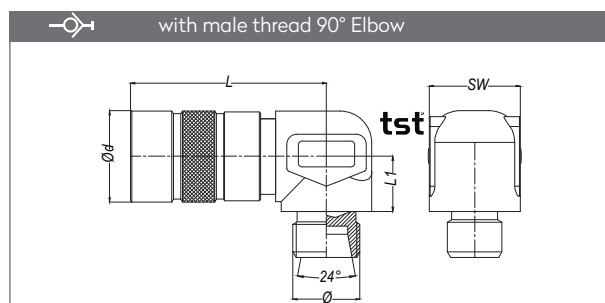

Part No.	DN	Ø	Ød	L	L1	SW
102.06 EGB 13-90	06	BSP 1/4"	21.8	47.5	13.15	21.7
102.07 EGB 13-90	07	BSP 1/4"	21.8	47.5	13.15	21.7
102.09 EGB 17-90	09	BSP 3/8"	28	65.2	15.5	26.8



Part No.	DN	Ø	Ød	L	L1	SW
102.06 EGBM 16-10-90	06	M16x1.5	22	47.5	13.15	21.7
102.07 EGBM 16-10-90	07	M16x1.5	22	47.5	13.15	21.7
102.09 EGBM 18-12-90	09	M18x1.5	28	65.2	15.5	26.8

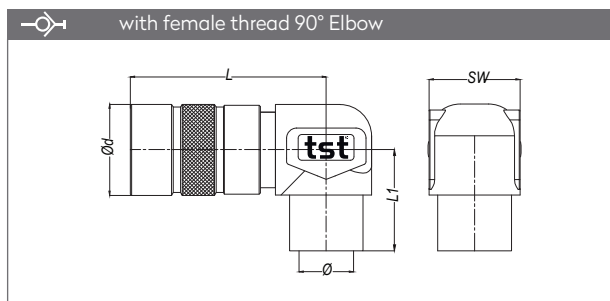

Part No.	DN	Ø	Ød	L	L1	SW
102.06 DGB 13-90	06	BSP 1/4"	21.8	47.5	24.15	21.7
102.07 DGB 13-90	07	BSP 1/4"	21.8	47.5	24.15	21.7
102.09 DGB 17-90	09	BSP 3/8"	28	71	25.7	26.8

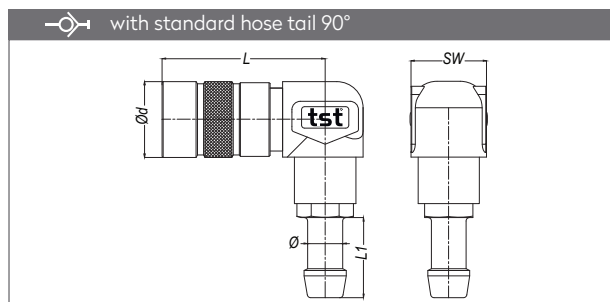

Part No.	DN	Ø	Ød	L	L1	SW
102.06 HGB 10-90	06	Ø10	21.8	47.5	23	21.7
102.07 HGB 10-90	07	Ø10	21.8	47.5	23	21.7
102.09 HGB 13-90	09	Ø13	28	71	27.5	26.8

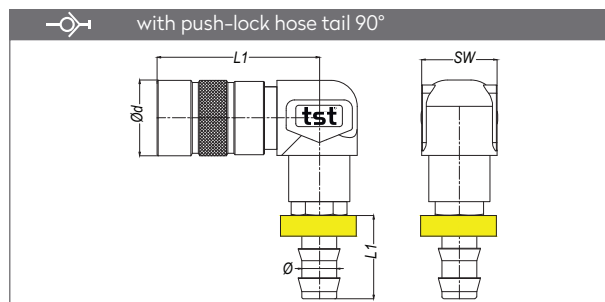

Part No.	DN	Ø	Ød	L	L1	SW
102.06 FGB 10-90	06	Ø10	21.8	47.5	24	21.7
102.07 FGB 10-90	07	Ø10	21.8	47.5	24	21.7
102.09 FGB 13-90	09	Ø13	28	71	28	26.8

MOULD COOLING COUPLINGS
KÜHLUNGSELEMENTE FÜR WERKZEUGE

SERIE 102



PLUGS STECKNIPPEL

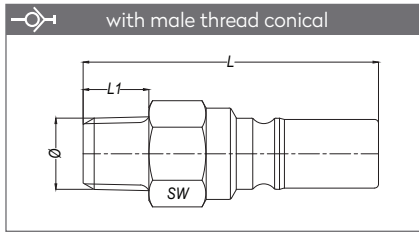

Part No.	DN	Ø	L	L1	SW
102.06 RUB 13	06	BSPT 1/4"	54	12	17
102.06 TUB 13	06	NPT 1/4"	54	12	17
102.07 RUB 13	07	BSPT 1/4"	54	12	17
102.07 TUB 13	07	NPT 1/4"	54	12	17
102.09 RUB 17	09	BSPT 3/8"	67	11	23
102.09 TUB 17	09	NPT 3/8"	69	13	23
102.12 RUB 21	12	BSPT 1/2"	87.9	17	30
102.12 TUB 21	12	NPT 1/2"	87.9	18	30

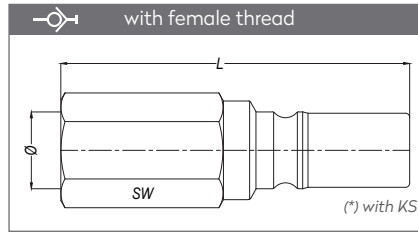

Part No.	DN	Ø	L	SW
102.03 DUB 10	03	BSP 1/8"	45.3	13
102.06 DUB 13*	06	BSP 1/4"	59	17
102.07 DUB 13	07	BSP 1/4"	59	17
102.09 DUB 17*	09	BSP 3/8"	71	23
102.09 NUB 17	09	NPT 3/8"	71	23
102.12 DUB 21	12	BSP 1/2"	89	30
102.12 NUB 21	12	NPT 1/2"	89	30

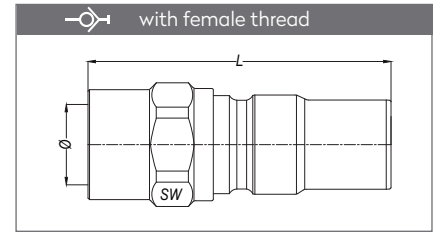

Part No.	DN	Ø	L	SW
102.16 DUB 26	16	BSP 3/4"	102	38
102.16 NUB 26	16	BSP 3/4"	102	38

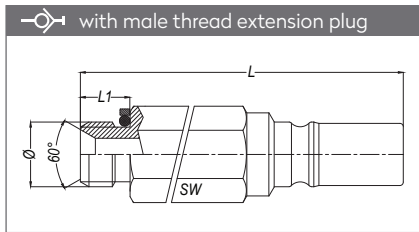

Part No.	DN	Ø	L	L1	SW
102.06 OUB 13x65	06	BSP 1/4"	77	10	17
102.06 OUB 13x80	06	BSP 1/4"	92	10	17
102.06 OUB 13x110	06	BSP 1/4"	122	10	17
102.07 OUB 13x65	07	BSP 1/4"	77	10	17
102.07 OUB 13x80	07	BSP 1/4"	92	10	17
102.07 OUB 13x110	07	BSP 1/4"	122	10	17

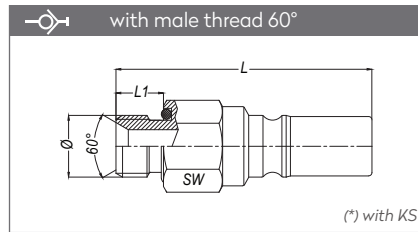

Part No.	DN	Ø	L	L1	SW
102.03 OUB 10	03	BSP 1/8"	39.6	8.2	13
102.06 OUB 13*	06	BSP 1/4"	54	10	17
102.06 OUB 17	06	BSP 3/8"	53	10	21
102.07 OUB 13*	07	BSP 1/4"	54	10	17
102.07 OUB 17	07	BSP 3/8"	53	10	21
102.09 OUB 17	09	BSP 3/8"	65	9	23
102.12 OUB 21	12	BSP 1/2"	84.9	14	30

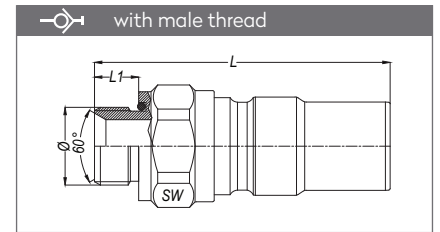

Part No.	DN	Ø	L	L1	SW
102.16 OUB 26	16	BSP 3/4"	100.5	15	38
102.25 OUB 33	25	BSP 1"	124	21	55
102.25 OUB 42	25	BSP 1 1/4"	124	21	55
102.25 DUB 33	25	BSP 1"	126.6	-	55
102.25 DUB 42	25	BSP 1 1/4"	126.6	-	55

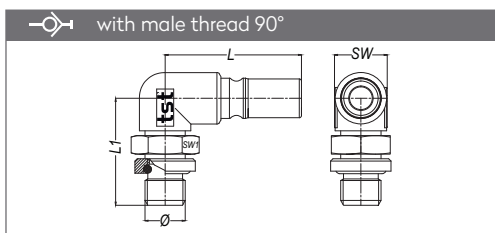

Part No.	DN	Ø	L	L1	SW	SW1
102.06 OUB 13-90	6	BSP 1/4"	50	34.5	17	19
102.07 OUB 13-90	7	BSP 1/4"	50	34.5	17	19

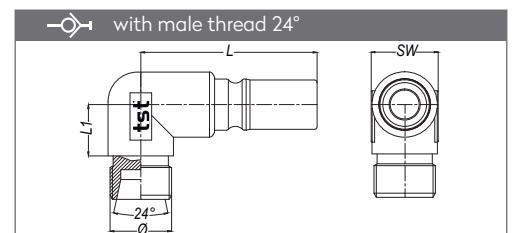

Part No.	DN	Ø	L	L1	SW
102.06 EUBM 16-10-90	6	M16x1.5-Ø10	44.2	13	17

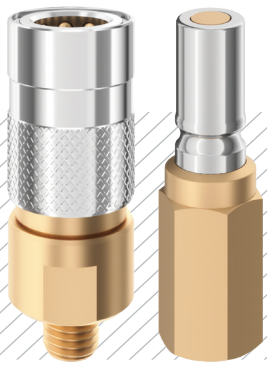

DN 3-25

SERIE 102-OH

MOULD COOLING COUPLINGS
KÜHLUNGSELEMENTE FÜR WERKZEUGE

Materials

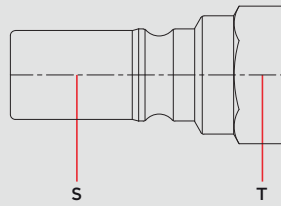
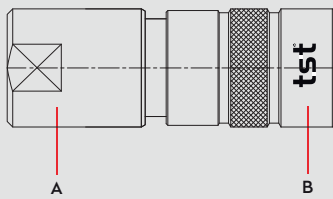

Material Code

A = Brass

B = AISI 420 / Chrome Plated

*Serie 102.12 - 102.16 - 102.25 → AISI420

S = AISI 420

T = Brass



0 - 50 bar



-26° to + 200°C (FPM)

Shut Off
Type



COUPLING
PLUG

TST 102.03-OH	TST 102.06-OH	TST 102.07-OH	TST 102.09-OH	TST 102.12-OH	TST 102.16-OH	TST 102.25-OH
OV 100 - 00180	OV 178 - 01240	OV 157 - 01300	OV 200 - 01700	OV 262 - 02345	OV 270 - 01410	OV 262 - 02345
OV 100 - 00870	OV 190 - 00370	OV 157 - 01500	OV 200 - 00650	OV 262 - 00835-88	OV 353 - 03000	OV 353 - 04345
OV 120 - 00600	OV 157 - 01500	OV 190 - 00420	OV 178 - 01875	OV 262 - 02665-88	OV 262 - 03615	OV 262 - 04890
TST 102.03	TST 102.06	TST 102.07	TST 102.09	TST 102.12	TST 102.16	TST 102.25
OV 100 - 00180	OV 190 - 00370	OV 190 - 00420	OV 200 - 00650	OV 262 - 02025	OV 262 - 01435	OV 262 - 02345
OV 120 - 00600	OV 178 - 01110	OV 178 - 01110	OV 178 - 01520	OV 250 - 00800-88	OV 262 - 02840	OV 262 - 04255

DN

TST 102.03 → 3 mm
TST 102.06 → 6 mm
TST 102.07 → 7 mm
TST 102.09 → 9 mm
TST 102.12 → 12 mm
TST 102.16 → 16 mm
TST 102.25 → 25 mm

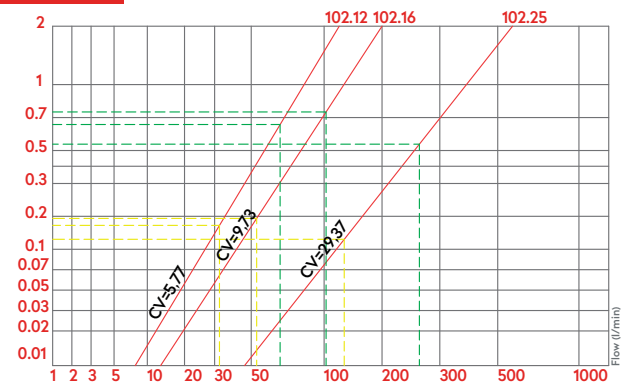
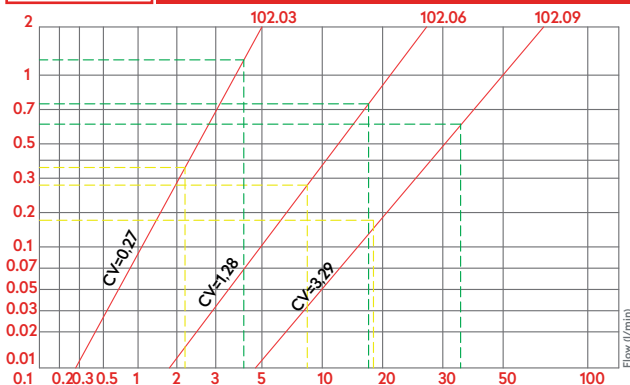

Options

EPDM

FFKM
please ask

E2

AISI303
Serie 102-H4

Applications

- Blow Moulding
- Injection Moulding

Compatible with

RECTUS

206, 209

MOULD COOLING COUPLINGS
KÜHLUNGSELEMENTE FÜR WERKZEUGE

SERIE 102-OH



QUICK COUPLINGS SCHNELLKUPPLUNGEN

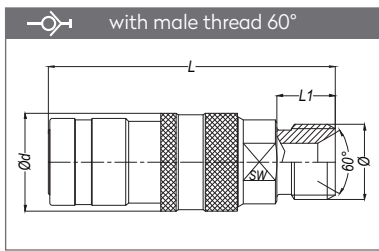

Part No.	DN	Ø	Ød	L	L1	SW
102.03 EGB 13-OH	03	BSP 1/4"	17	49.5	10	13

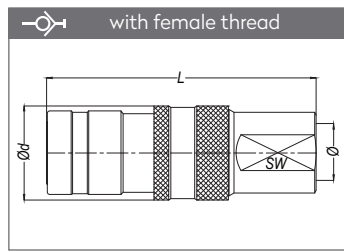

Part No.	DN	Ø	Ød	L	SW
102.03 DGB 10-OH	03	BSP 1/8"	17	48.5	13

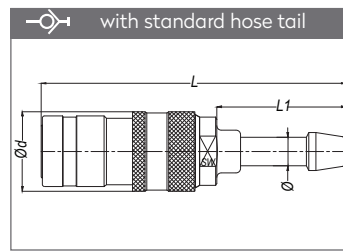

Part No.	DN	Ø	Ød	L	L1	SW
102.03 HGB 06-OH	03	6	17	64.85	27.5	13

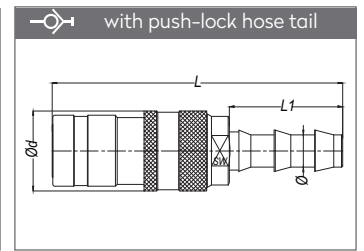

Part No.	DN	Ø	Ød	L	L1	SW
102.03 FGB 06-OH	03	06	17	61.5	24	13
102.06 FGB 10-OH	03	10	17	63.5	26	13

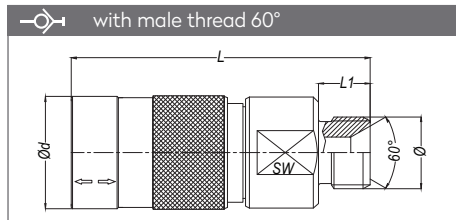

Part No.	DN	Ø	Ød	L	L1	SW
102.06 EGB 13-OH	06	BSP 1/4"	22	58.4	10	20
102.07 EGB 13-OH	07	BSP 1/4"	22	58.4	10	20
102.09 EGB 17-OH	09	BSP 3/8"	29.2	77.9	12	24
102.12 EGB 21-OH	12	BSP 1/2"	44	106.9	12	30

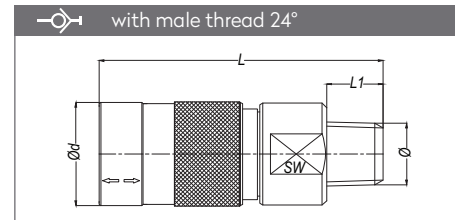

Part No.	DN	Ø	Ød	L	L1	SW
102.06 EGBM 16-10-OH	06	M16x1.5	22	61.1	11	20
102.07 EGBM 16-10-OH	07	M16x1.5	22	61.1	11	20
102.09 EGBM 18-12-OH	09	M18x1.5	29.2	77.9	12	24
102.12 EGBM 20-14-OH	12	M20x1.5	44	105.9	13	27

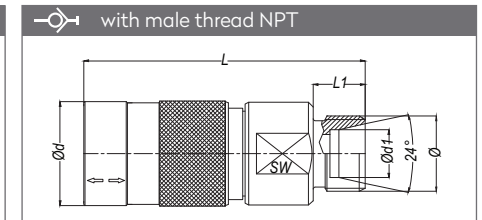

Part No.	DN	Ø	Ød	L	L1	SW
102.06 TGB 13-OH	06	NPT 1/4"	22	60.9	13	20
102.07 TGB 13-OH	07	NPT 1/4"	22	60.9	13	20
102.09 TGB 17-OH	09	NPT 3/8"	29.2	61.9	13	24

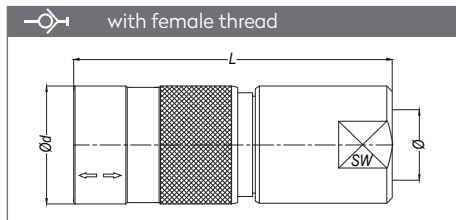

Part No.	DN	Ø	Ød	L	SW
102.06 DGB 13-OH	06	BSP 1/4"	22	59.6	20
102.07 DGB 13-OH	07	BSP 1/4"	22	59.6	20
102.09 DGB 17-OH	09	BSP 3/8"	29.2	76.5	24
102.12 DGB 21-OH	12	BSP 1/2"	44	100.9	27

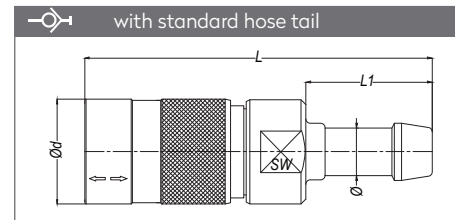

Part No.	DN	Ø	Ød	L	L1	SW
102.06 HGB 10-OH	06	Ø10	22	82	26.5	20
102.07 HGB 10-OH	07	Ø10	22	82	26.5	20
102.09 HGB 13-OH	09	Ø13	28	92.5	27.5	24

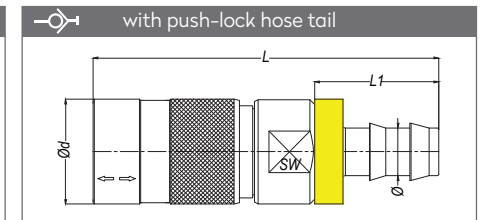

Part No.	DN	Ø	Ød	L	L1	SW
102.06 FGB 10-OH	06	Ø10	22	77.2	28	20
102.07 FGB 10-OH	07	Ø10	22	77.2	28	20
102.09 FGB 13-OH	09	Ø13	29.2	93.5	28	24
102.12 FGB 16-OH	12	Ø16	44	132.9	28	27

Part No.	DN	Ø	Ød	L	SW
102.06 NGB 13-OH	06	NPT 1/4"	22	59.6	20
102.07 NGB 13-OH	07	NPT 1/4"	22	59.6	20
102.09 NGB 17-OH	09	NPT 3/8"	29.2	76.5	24
102.12 NGB 21-OH	12	NPT 1/2"	44	100.9	27

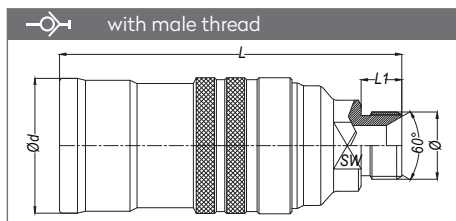

Part No.	DN	Ø	Ød	L	L1	SW
102.16 EGB 26-OH	16	BSP 3/4"	53.6	134.8	16	32

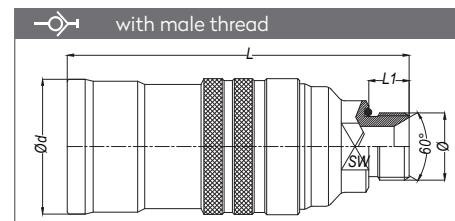

Part No.	DN	Ø	Ød	L	L1	SW
102.16 OGB 26-OH	16	BSP 3/4"	53.6	134.8	16	32

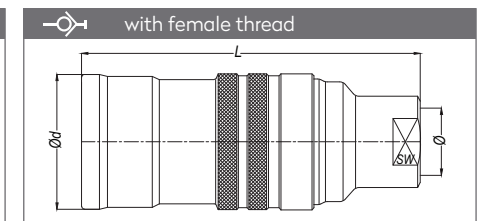

Part No.	DN	Ø	Ød	L	SW
102.16 DGB 26-OH	16	BSP 3/4"	53.6	133.5	32
102.16 NGB 26-OH	16	BSP 3/4"	53.6	133.5	32
102.25 DGB 33-OH	25	BSP 1"	66.5	148.1	55
102.25 DGB 42-OH	25	BSP 1 1/4"	66.5	148.1	55



MOULD COOLING COUPLINGS
KÜHLUNGSELEMENTE FÜR WERKZEUGE

SERIE 102-OH

QUICK COUPLINGS SCHNELLKUPPLUNGEN

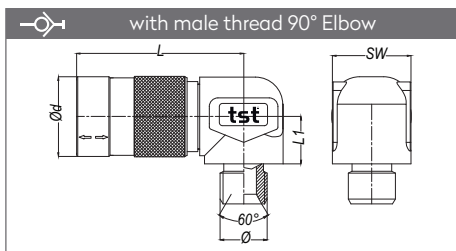

Part No.	DN	Ø	Ød	L	L1	SW
102.06 EGB 13-90-OH	06	BSP 1/4"	22	47	13.15	21.7
102.07 EGB 13-90-OH	07	BSP 1/4"	22	47	13.15	21.7
102.09 EGB 17-90-OH	09	BSP 3/8"	29.2	71	15.5	26.8

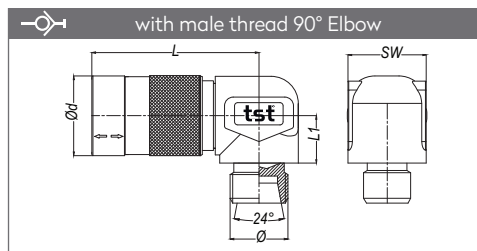

Part No.	DN	Ø	Ød	L	L1	SW
102.06 EGBM 16-10-90-OH	06	M16x1.5	22	47	13.15	21.7
102.07 EGBM 16-10-90-OH	07	M16x1.5	22	47	13.15	21.7
102.09 EGBM 18-12-90-OH	09	M18x1.5	29.2	71	15.5	26.8

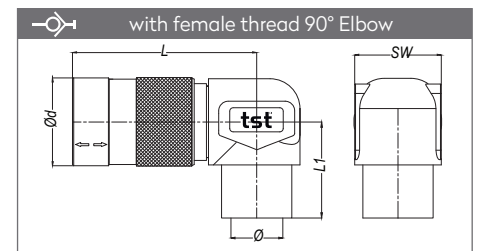

Part No.	DN	Ø	Ød	L	L1	SW
102.06 DGB 13-90-OH	06	BSP 1/4"	22	47	24.15	21.7
102.07 DGB 13-90-OH	07	BSP 1/4"	22	47	24.15	21.7
102.09 DGB 17-90-OH	09	BSP 3/8"	29.2	71	25.7	26.8

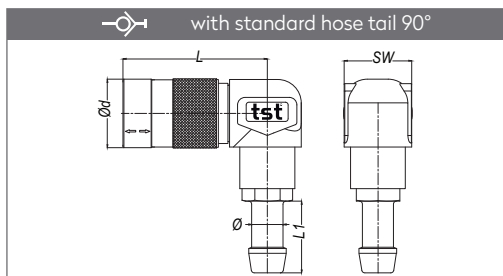

Part No.	DN	Ø	Ød	L	L1	SW
102.06 HGB 10-90-OH	06	Ø10	22	47	23	21.7
102.07 HGB 10-90-OH	07	Ø10	22	47	23	21.7
102.09 HGB 13-90-OH	09	Ø13	31	71	27.5	26.8

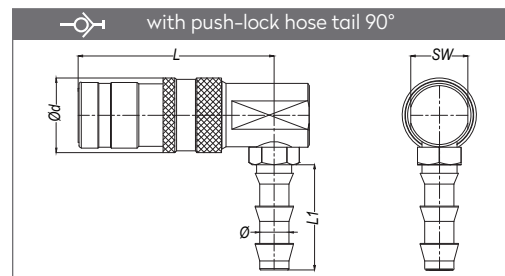

Part No.	DN	Ø	Ød	L	L1	SW
102.06 FGB 10-90-OH	06	Ø10	22	47	24	21.7
102.07 FGB 10-90-OH	07	Ø10	22	47	24	21.7
102.09 FGB 13-90-OH	09	Ø13	31	71	28	26.8

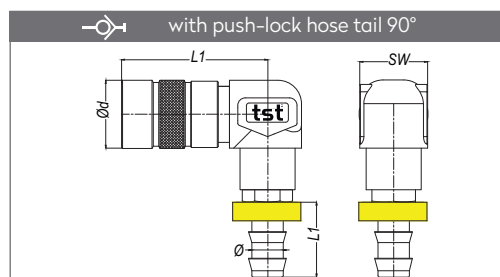

Part No.	DN	Ø	Ød	L	L1	SW
102.03 FGB 06-90-OH	03	06	17	52.7	24	13

MOULD COOLING COUPLINGS
KÜHLUNGSELEMENTE FÜR WERKZEUGE

SERIE 102-OH

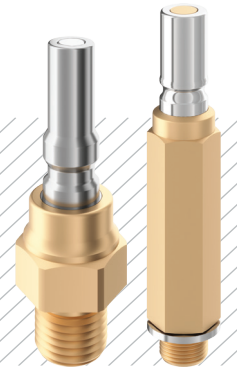

PLUGS STECKNIPPEL

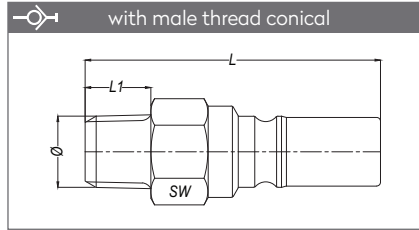

Part No.	DN	Ø	L	L1	SW
102.06 RUB 13	06	BSPT 1/4"	54	12	17
102.06 TUB 13	06	NPT 1/4"	54	12	17
102.07 RUB 13	07	BSPT 1/4"	54	12	17
102.07 TUB 13	07	NPT 1/4"	54	12	17
102.09 RUB 17	09	BSPT 3/8"	67	11	23
102.09 TUB 17	09	NPT 3/8"	69	13	23
102.12 RUB 21	12	BSPT 1/2"	87.9	17	30
102.12 TUB 21	12	NPT 1/2"	87.9	18	30

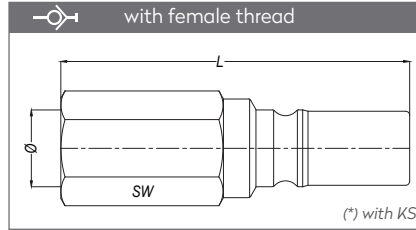

Part No.	DN	Ø	L	SW
102.03 DUB 10	03	BSP 1/8"	45.3	13
102.06 DUB 13*	06	BSP 1/4"	59	17
102.07 DUB 13	07	BSP 1/4"	59	17
102.09 DUB 17*	09	BSP 3/8"	71	23
102.09 NUB 17	09	NPT 3/8"	71	23
102.12 DUB 21	12	BSP 1/2"	89	30
102.12 NUB 21	12	NPT 1/2"	89	30

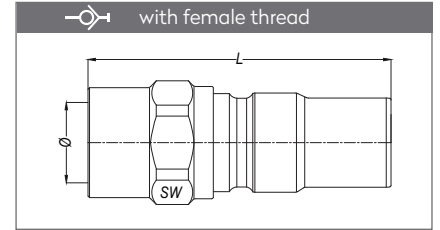

Part No.	DN	Ø	L	SW
102.16 DUB 26	16	BSP 3/4"	102	38
102.16 NUB 26	16	BSP 3/4"	102	38

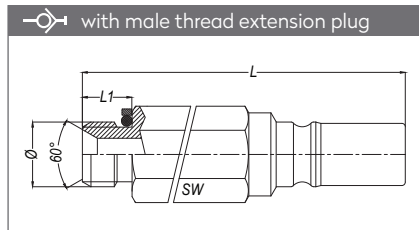

Part No.	DN	Ø	L	L1	SW
102.06 OUB 13x65	06	BSP 1/4"	77	10	17
102.06 OUB 13x80	06	BSP 1/4"	92	10	17
102.06 OUB 13x110	06	BSP 1/4"	122	10	17
102.07 OUB 13x65	07	BSP 1/4"	77	10	17
102.07 OUB 13x80	07	BSP 1/4"	92	10	17
102.07 OUB 13x110	07	BSP 1/4"	122	10	17

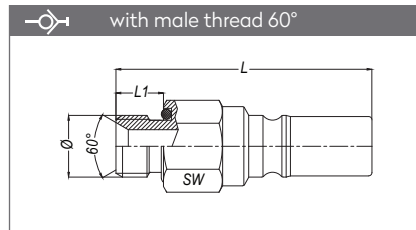

Part No.	DN	Ø	L	L1	SW
102.03 OUB 10	03	BSP 1/8"	39.6	8.2	13
102.06 OUB 13	06	BSP 1/4"	54	10	17
102.06 OUB 17	06	BSP 3/8"	53	10	21
102.07 OUB 13	07	BSP 1/4"	54	10	17
102.07 OUB 17	07	BSP 3/8"	53	10	21
102.09 OUB 17	09	BSP 3/8"	65	9	23
102.12 OUB 21	12	BSP 1/2"	84.9	14	30

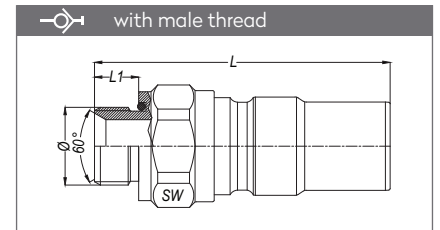

Part No.	DN	Ø	L	L1	SW
102.16 OUB 26	16	BSP 3/4"	100.5	15	38
102.25 OUB 33	25	BSP 1"	124	21	55
102.25 OUB 42	25	BSP 1 1/4"	124	21	55
102.25 DUB 33	25	BSP 1"	126.6	-	55
102.25 DUB 42	25	BSP 1 1/4"	126.6	-	55

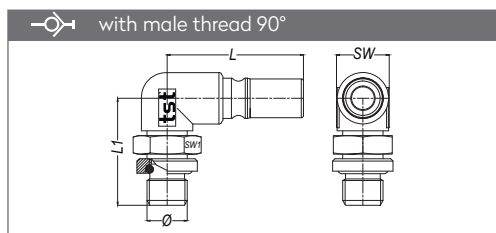

Part No.	DN	Ø	L	L1	SW	SW1
102.06 OUB 13-90	6	BSP 1/4"	50	34.5	17	19
102.07 OUB 13-90	7	BSP 1/4"	50	34.5	17	19

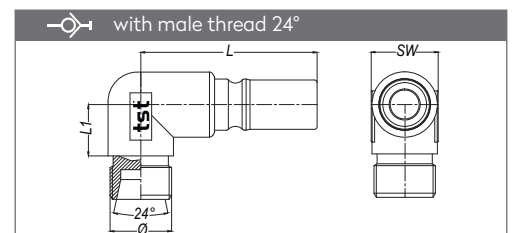

Part No.	DN	Ø	L	L1	SW
102.06 EUBM 16-10-90	6	M16x1.5-Ø10	44.2	13	17

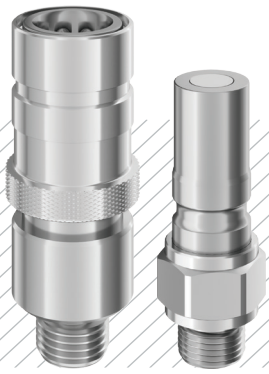

DN 3-16

HYDRAULIC COUPLINGS
HYDRAULISCHE KUPPLUNGEN

SERIE 102H4

Materials

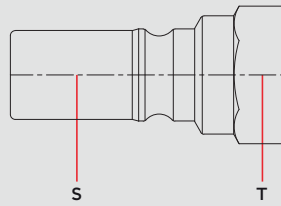
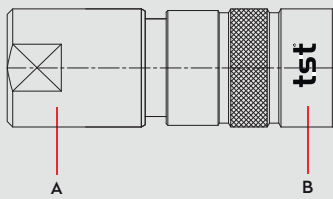

Material Code

A = AISI 303

B = AISI 420 / Chrome Plated
*Serie 102.12 - 102.16 → AISI420

S = AISI 420

T = AISI 303



DN 3 → 0 - 450 bar
DN 6-16 → 0 - 180 bar



-26° to + 200°C (FPM)

Shut Off
Type



DN

TST 102.03H4 → 3 mm
TST 102.06H4 → 6 mm
TST 102.07H4 → 7 mm

TST 102.09H4 → 9 mm
TST 102.12H4 → 12 mm
TST 102.16H4 → 16 mm

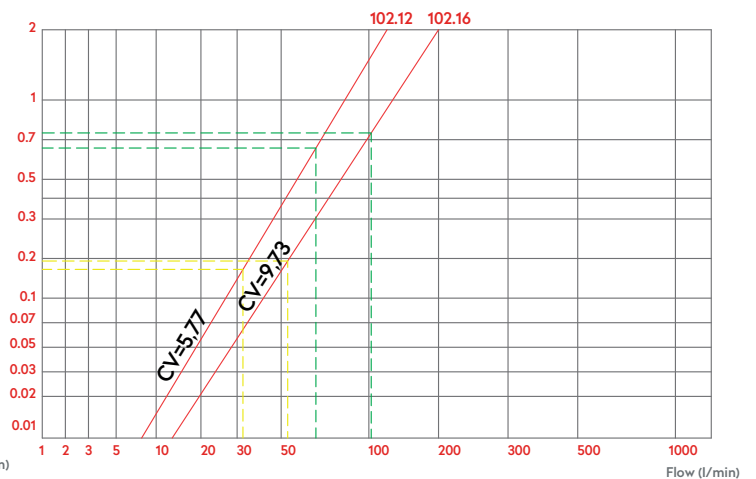
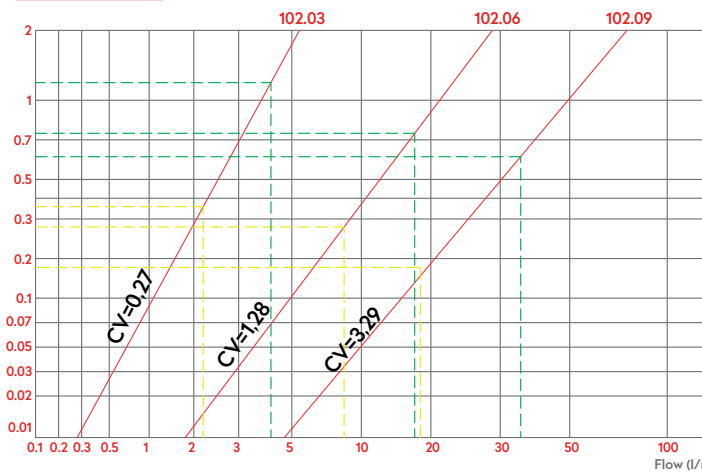

Options

EPDM

FFKM
please ask

E2

Applications

- Blow Moulding
- Injection Moulding

Compatible with

RECTUS 206, 209

HYDRAULIC COUPLINGS
HYDRAULISCHE KUPPLUNGEN

SERIE 102H4



QUICK COUPLINGS SCHNELLKUPPLUNGEN

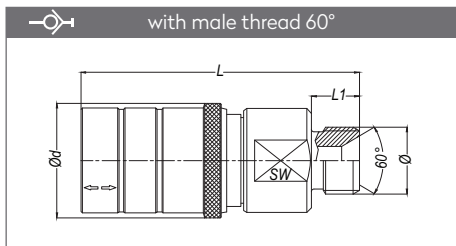

Part No.	DN	Ø	Ød	L	L1	SW
102.03 EGB 13-OH-H4	03	BSP 1/4"	17	49.5	10	13
102.06 EGB 13-OH-H4	06	BSP 1/4"	24	49.5	10	20
102.07 EGB 13-OH-H4	07	BSP 1/4"	24	49.5	10	20
102.09 EGB 17-OH-H4	09	BSP 3/8"	31	77.9	12	24
102.12 EGB 21-OH-H4	12	BSP 1/2"	48	109	14	27
102.16 EGB 26-OH-H4	16	BSP 3/4"	53.6	108	14	32

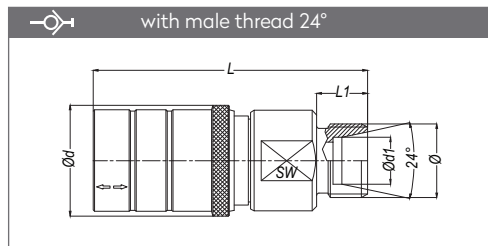

Part No.	DN	Ø	Ød	L	L1	SW
102.03 EGBM 12-06-OH-H4	03	M12x1.5	17	49.5	10	13
102.06 EGBM 16-08-OH-H4	06	M16x1.5	24	59.9	11	20
102.07 EGBM 16-08-OH-H4	07	M16x1.5	24	59.9	11	20
102.09 EGBM 20-12-OH-H4	09	M20x1.5	31	78.5	13	24
102.12 EGBM 22-14-OH-H4	12	M22x1.5	48	123	13	27
102.16 EGBM 30-22-OH-H4	16	M30x2	53.6	132.8	14	32

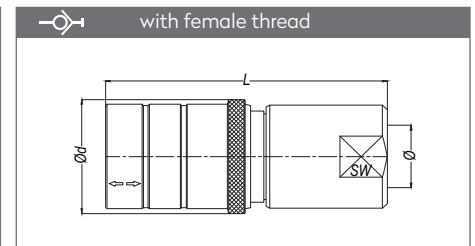

Part No.	DN	Ø	Ød	L	SW
102.03 DGB 10-OH-H4	3	BSP 1/8"	17	48.5	13
102.06 DGB 13-OH-H4	6	BSP 1/4"	24	59.6	20
102.06 NGB 13-OH-H4	6	NPT 1/4"	24	59.6	20
102.06 DGB 17-OH-H4	6	BSP 3/8"	24	62.1	20
102.07 DGB 13-OH-H4	7	BSP 1/4"	24	59.6	20
102.07 NGB 13-OH-H4	7	NPT 1/4"	24	59.6	20
102.09 DGB 17-OH-H4	9	BSP 3/8"	31	76.5	24
102.09 NGB 17-OH-H4	9	NPT 3/8"	31	76.5	24
102.12 DGB 21-OH-H4	12	BSP 1/2"	48	103	27
102.12 NGB 21-OH-H4	12	NPT 1/2"	48	103	27
102.16 DGB 26-OH-H4	16	BSP 3/4"	53.6	133.5	32

PLUGS STECKNIPPEL

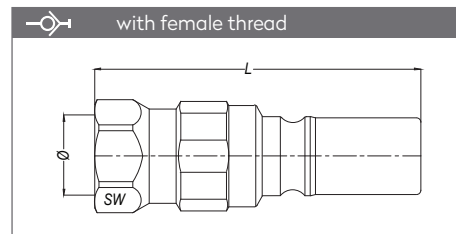

Part No.	DN	Ø	L	SW
102.03 DUB 10-H4	3	BSP 1/8"	43.5	13
102.06 DUB 13-H4	6	BSP 1/4"	59	17
102.06 NUB 13-H4	6	NPT 1/4"	58.5	17
102.06 DUB 17-H4	6	BSP 3/8"	61	21
102.07 DUB 13-H4	7	BSP 1/4"	59	17
102.07 NUB 13-H4	7	NPT 1/4"	58.5	17
102.09 DUB 17-H4	9	BSP 3/8"	71	23
102.09 NUB 17-H4	9	NPT 3/8"	71	23
102.12 DUB 21-H4	12	BSP 1/2"	89.9	30
102.12 NUB 21-H4	12	NPT 1/2"	89.9	30

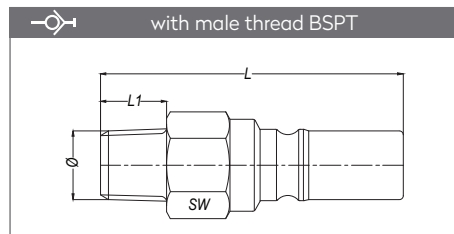

Part No.	DN	Ø	L	L1	SW
102.06 RUB 13-H4	6	BSPT 1/4"	54	42	17
102.06 OUB 13-H4	6	NPT 1/4"	54	42	17
102.07 RUB 13-H4	7	BSPT 1/4"	54	42	17
102.07 TUB 13-H4	7	NPT 1/4"	54	42	17
102.09 RUB 17-H4	9	BSPT 3/8"	67	56	23
102.09 TUB 17-H4	9	NPT 3/8"	67	56	23
102.12 RUB 21-H4	12	BSPT 1/2"	83.9	70.9	30
102.12 TUB 21-H4	12	NPT 1/2"	83.9	70.9	30

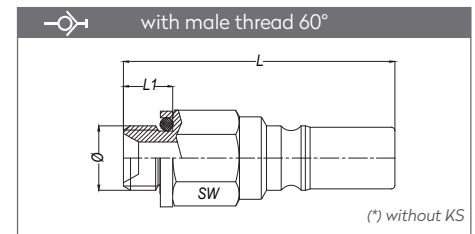

Part No.	DN	Ø	L	L1	SW
102.03 OUB 10-H4	3	BSP 1/8"	39.6	31.4	13
102.06 OUB 13-H4	6	BSP 1/4"	54	44	17
102.07 OUB 13-H4	7	BSP 1/4"	54	44	17
102.09 OUB 17-H4	9	BSP 3/8"	65	56	23
102.12 OUB 21-H4*	12	BSP 1/2"	84.9	70.9	30
102.16 OUB 26-H4*	16	BSP 3/4"	100.5	85.5	38

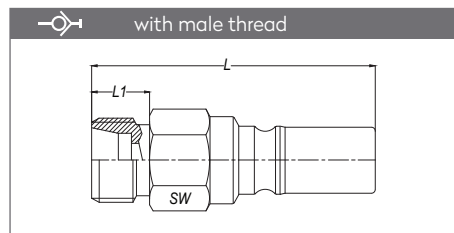

Part No.	DN	Ø	L	L1	SW
102.03 EUBM 12-06-H4	03	M12x1.5	39.6	31.4	13
102.06 EUBM 16-08-H4	06	M16x1.5	53	43	17
102.07 EUBM 16-08-H4	07	M16x1.5	53	43	17
102.09 EUBM 20-12-H4	09	M20x1.5	66	56	23
102.12 EUBM 22-14-H4	12	M22x1.5	83.9	70.9	30

HYDRAULIC COUPLINGS
HYDRAULISCHE KUPPLUNGEN

SERIE 103

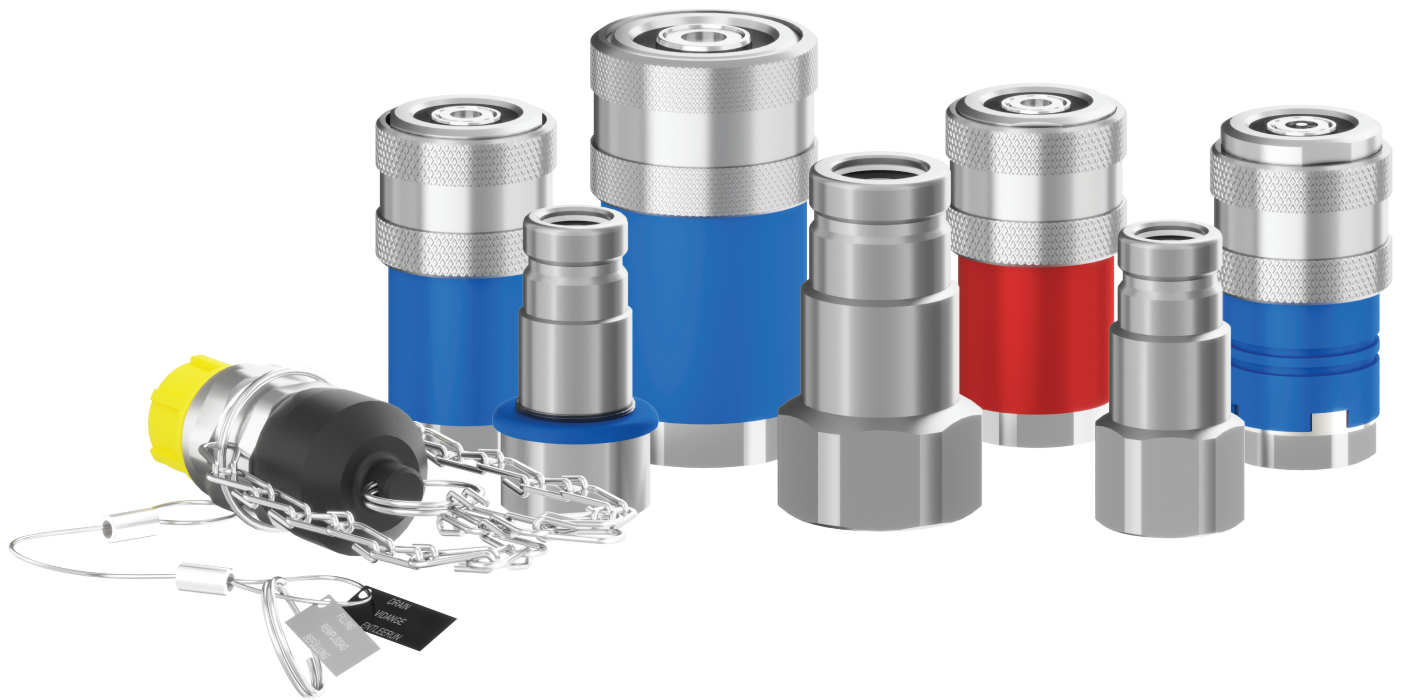



Materials

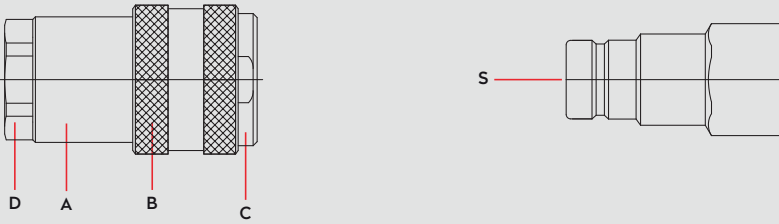

Material Code

- A = Blue -Red Aluminum Plated
- B = Hardened Steel Zinc Plated
- C = Hardened AISI 420
- D = AISI 303
- S = AISI 420

TST 103.08 → 0 - 450 bar
TST 103.11 → 0 - 350 bar
TST 103.12 → 0 - 350 bar

-26° to + 200°C (FPM)

Shut Off Type

Residual Pressure	max. Serie	103.08/PD	103.12/PD
	Coupling	40	
	Plug	120	

FLOW

TST 103.08 → 15 lt/min
TST 103.11 → 27 lt/min
TST 103.12 → 35 lt/min

DN

TST 103.08 → 8 mm
TST 103.11 → 11 mm
TST 103.12 → 12 mm

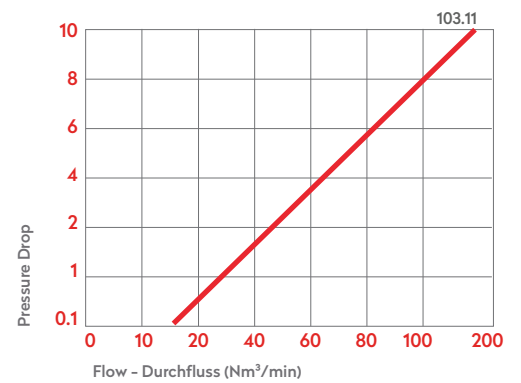
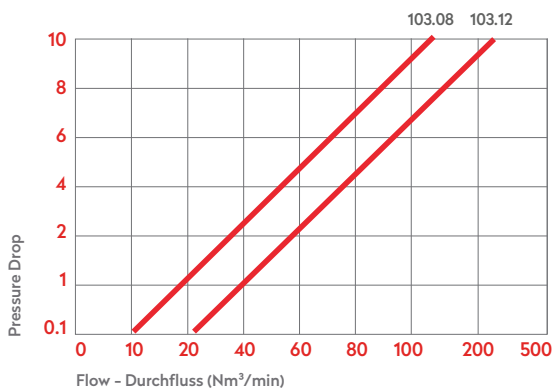

Options

- E1
- Id. Ring
- PD
- NBR

Applications

- Hydraulic oil circuits

Compatible with

HYDRAULIC COUPLINGS
 HYDRAULISCHE KUPPLUNGEN

SERIE 103



QUICK COUPLINGS SCHNELLKUPPLUNGEN

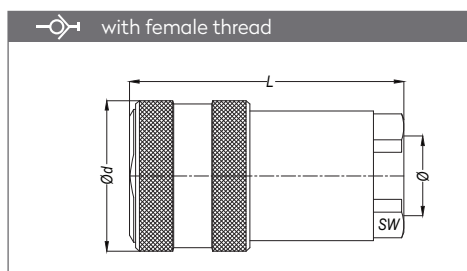

Part No.	DN	Ø	L	Ød	SW
103.08 DGB 21	8	BSP 1/2"	72	39.5	30
103.11 DGB 21	11	BSP 1/2"	72	39.5	30
103.12 DGB 26	12	BSP 3/4"	89	49.5	41

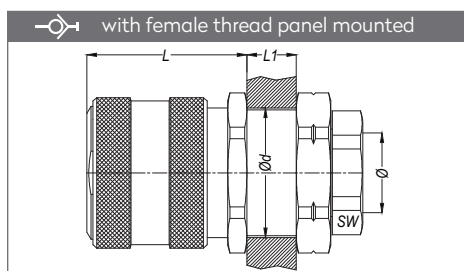

Part No.	DN	Ø	Ød	L	L1	SW
103.08 MGB 21	8	BSP 1/2"	M34x1	42	13	30
103.12 MGB 26	12	BSP 3/4"	M44x1.5	46	22	41

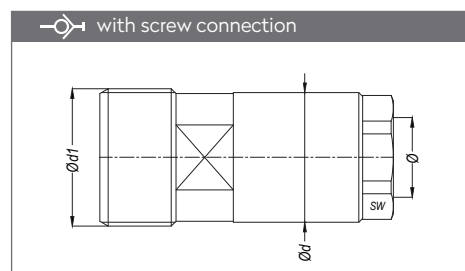

Part No.	DN	Ø	L	Ød	Ød1	SW
103.08 VDGB 21	8	BSP 1/2"	77	34	M36x2	30
103.12 VDGB 26	12	BSP 3/4"	94.5	45	M43x2	41

PLUGS STECKNIPPEL

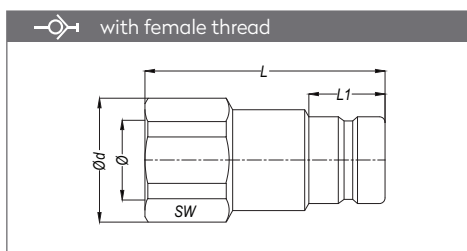

Part No.	DN	Ø	Ød	L	L1	SW
103.08 DUB 21	8	BSP 1/2"	32.5	63	20	30
103.12 DUB 26	12	BSP 3/4"	44.5	74	25	41

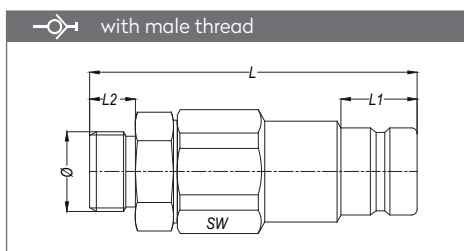

Part No.	DN	Ø	Ød	L	L1	SW
103.08 EUB 21	8	BSP 1/2"	32.5	74	12	30
103.08 EUBM 22	8	M22x1.5	32.5	74	12	30
103.08 EUBM 24	8	M24x1.5	32.5	76	14	30

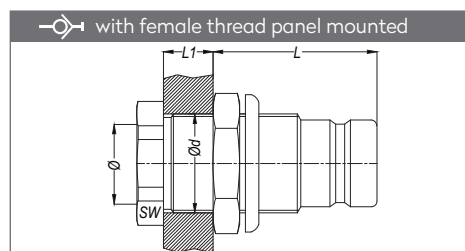

Part No.	DN	Ø	Ød	L	L1	SW
103.08 MUB 21	8	BSP 1/2"	27	36	22	30
103.12 MUB 26	12	BSP 3/4"	35	31	22	38

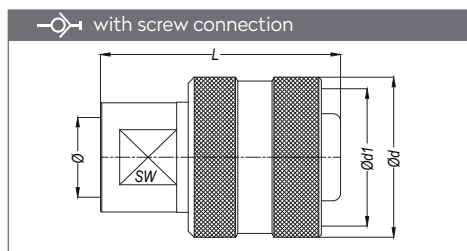

Part No.	DN	Ø	Ød	Ød1	L	SW
103.08 VDUB 21	8	BSP 1/2"	42	M36x2	63	26
103.12 VDUB 26	12	BSP 3/4"	49	M43x2	73	31

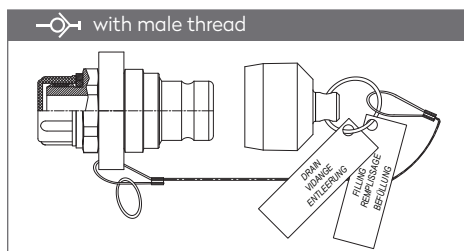

Part No.	DN	Ø	L	L1	SW
103.11 EUB 21	11	BSP 1/2"	63.5	13	30
103.11 EUBM 24	11	M24x1.5	64.5	15	30

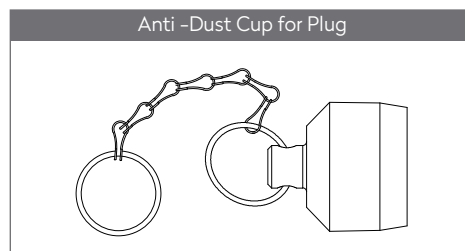

Part No.	DN
103.08 KU 21	8
103.12 KU 26	12

CONNECTION UNDER PRESSURE VERBINDUNG UNTER DRUCK

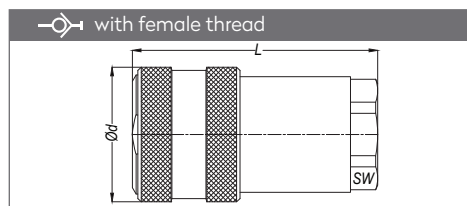

Part No.	DN	Ø	Ød	L	SW
103.08 PDGB 21	8	BSP 1/2"	39.5	72	30
103.12 PDGB 26	12	BSP 3/4"	49.5	89	41

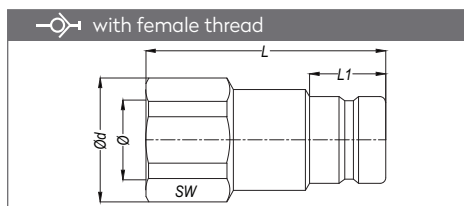

Part No.	DN	Ø	Ød	L	SW
103.11 PDUB 21	11	BSP 1/2"	20	63	30
103.11 PDUB 26	11	M24x1.5	25	74	41

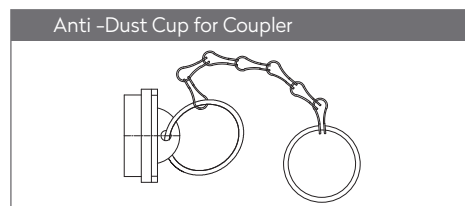

Part No.	DN
103.08 KG 21	8
103.12 KG 26	12



Materials

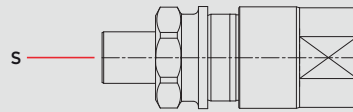
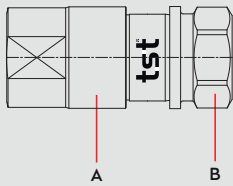

Material Code

A = AISI 303

B = AISI 303

S = AISI 303



-26° to + 200°C (FPM)

Shut Off Type



DN	4	6	8	12	15	20	25	37	50	75
Standard	160 bar	160 bar	160 bar	160 bar	160 bar	160 bar	160 bar	160 bar	160 bar	160 bar
H4	500 bar	500 bar	500 bar	250 bar	250 bar	250 bar	250 bar	NA	NA	NA

Standard Serie 104.04 -104.25

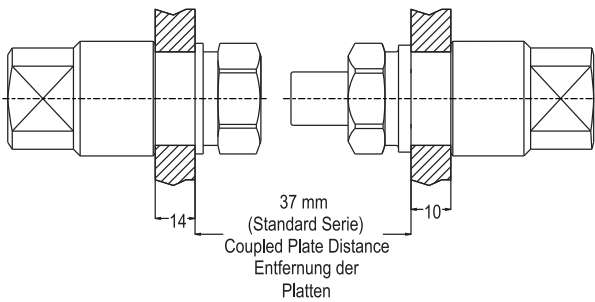

MP Serie 104.04 -104.25

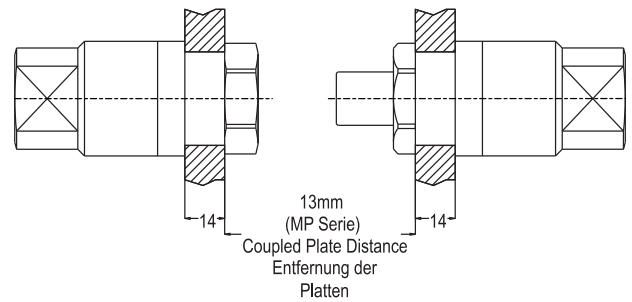

Options



Applications

- Automotive
- Steel Industry
- Die casting

Compatible with

Automatic Multi Couplings 104 with leakage free.
Coupling for multiple connection direct assembling systems.

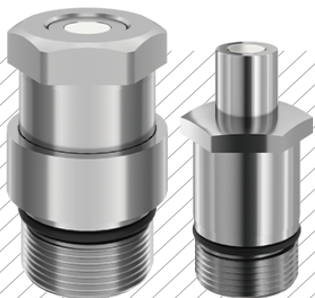

AUTOMATIC COUPLINGS
AUTOMATISCHE KUPPLUNGEN

SERIE 104

QUICK COUPLINGS SCHNELLKUPPLUNGEN

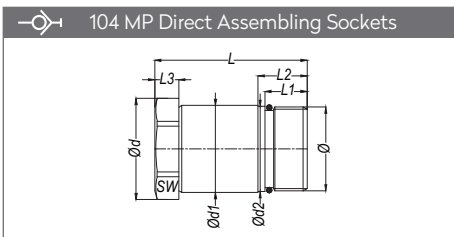

Part No.		DN	Ø	Ød	Ød1	Ød2	L	L1	L2	L3	SW
Standart Serie	H4										
104.04 EGBM 20MP	104.04 EGBM 20MP H4	4	M20x1.5	25	20.9	20.45	47	11.5	14	7.7	22
104.06 EGBM 24MP	104.06 EGBM 24MP H4	6	M24x1.5	29	24.9	24.5	47	11.5	14	7.7	26
104.08 EGBM 27MP	104.08 EGBM 27MP H4	8	M27x1.5	32.5	27.9	27.43	49	13.5	16	7.7	29
104.12 EGBM 36MP	104.12 EGBM 36MP H4	12	M36x1.5	42	36.95	36.5	57	21.5	24	7.7	38
104.15 EGBM 42MP	104.15 EGBM 42MP H4	15	M42x1.5	47	42.95	42.5	68	22.5	25	7.7	44
104.20 EGBM 52MP	104.20 EGBM 52MP H4	20	M52x2.0	62	53.95	53	74.5	25.5	28.5	7.7	55
104.25 EGBM 64MP	104.25 EGBM 64MP H4	25	M64x2.0	74.7	65.95	65	96.5	32	36	7.5	65

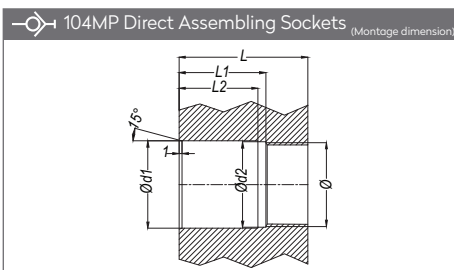

Part No.		DN	Ø	Ød1 G8	Ød2 F8	L +0.1	L1 +js13	L2 +js13
Standart Serie	H4							
104.04 EGBM 20MP	104.04 EGBM 20MP H4	4	M20x1.5	21.1	20.5	39.4	27.9	25.4
104.06 EGBM 24MP	104.06 EGBM 24MP H4	6	M24x1.5	25.1	24.5	39.4	27.9	25.4
104.08 EGBM 27MP	104.08 EGBM 27MP H4	8	M27x1.5	28.1	27.5	41.4	27.9	25.4
104.12 EGBM 36MP	104.12 EGBM 36MP H4	12	M36x1.5	37.1	36.5	49.4	27.9	25.4
104.15 EGBM 42MP	104.15 EGBM 42MP H4	15	M42x1.5	43.1	42.5	60.4	37.9	35.4
104.20 EGBM 52MP	104.20 EGBM 52MP H4	20	M52x2.0	54.1	53	66.9	41.4	38.4
104.25 EGBM 64MP	104.25 EGBM 64MP H4	25	M64x2.0	66.1	65	89.1	57	53

PLUGS STECKNIPPEL

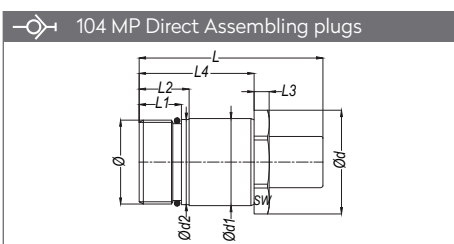

Part No.		DN	Ø	Ød1	Ød2	Ød	L	L1	L2	L3	L4	SW
Standart Serie	H4											
104.04 EUBM 20MP	104.04 EUBM 20MP H4	4	M20x1.5	20.9	20.5	25	53.5	11.5	14	5	35	22
104.06 EUBM 24MP	104.06 EUBM 24MP H4	6	M24x1.5	24.9	24.5	29	55	11.5	14	4.8	35	26
104.08 EUBM 27MP	104.08 EUBM 27MP H4	8	M27x1.5	27.9	27.43	-	59	13.5	16	4.8	37	30
104.12 EUBM 36MP	104.12 EUBM 36MP H4	12	M36x1.5	36.95	36.5	42	72	21.5	24	5	45	38
104.15 EUBM 42MP	104.15 EUBM 42MP H4	15	M42x1.5	42.95	42.5	47	87	22.5	25	5	56	44
104.20 EUBM 52MP	104.20 EUBM 52MP H4	20	M52x2.0	53.95	53	62	95.7	25.5	28.5	5	62.5	55
104.25 EUBM 64MP	104.25 EUBM 64MP H4	25	M64x2.0	65.95	65	74.7	126.7	32	36	4.9	84.5	65

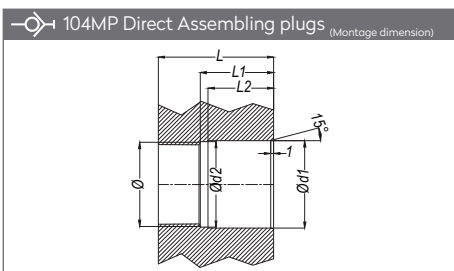

Part No.		DN	Ø	Ød1 G8	Ød2 F8	L +0.1	L1 +js13	L2 +js13
Standart Serie	H4							
104.04 EUBM 20MP	104.04 EUBM 20MP H4	4	M20x1.5	21.1	20.5	35.1	23.6	21.1
104.06 EUBM 24MP	104.06 EUBM 24MP H4	6	M24x1.5	25.1	24.5	35.1	23.6	21.1
104.08 EUBM 27MP	104.08 EUBM 27MP H4	8	M27x1.5	28.1	27.5	37.1	23.6	21.1
104.12 EUBM 36MP	104.12 EUBM 36MP H4	12	M36x1.5	37.1	36.5	45.1	23.6	21.1
104.15 EUBM 42MP	104.15 EUBM 42MP H4	15	M42x1.5	43.1	42.5	56.1	33.6	31.1
104.20 EUBM 52MP	104.20 EUBM 52MP H4	20	M52x2.0	54.1	53	62.6	37.1	34.1
104.25 EUBM 64MP	104.25 EUBM 64MP H4	25	M64x2.0	66.1	65	84.6	52.6	48.6

AUTOMATIC COUPLINGS

AUTOMATISCHE KUPPLUNGEN

SERIE 104



QUICK COUPLINGS SCHNELLKUPPLUNGEN

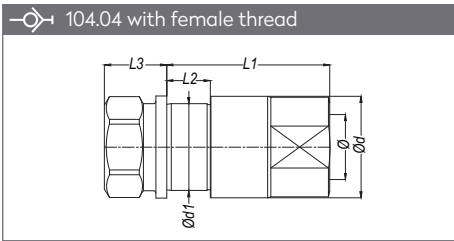

Part no.	DN	Ø	Ød	Ød1	L1		L2		L3	
					Standart Serie	MP Serie	Standart Serie	MP Serie	Standart Serie	MP Serie
104.04 DGB 13	4	BSP 1/4"	25	20.9	45	57.3	14	14	20	7.7
104.04 DGB 13-H4	4	BSP 1/4"	25	20.9	45	57.3	14	14	20	7.7
104.04 NGB 13	4	NPT 1/4"	25	20.9	45	57.3	14	14	20	7.7
104.04 NGB 13-H4	4	NPT 1/4"	25	20.9	45	57.3	14	14	20	7.7
104.06 DGB 17	6	BSP 3/8"	29	24.9	46.5	58.8	14	14	20	7.7
104.06 DGB 17-H4	6	BSP 3/8"	29	24.9	46.5	58.8	14	14	20	7.7
104.06 NGB 17	6	NPT 3/8"	29	24.9	46.5	58.8	14	14	20	7.7
104.06 NGB 17-H4	6	NPT 3/8"	29	24.9	46.5	58.8	14	14	20	7.7
104.08 DGB 21	8	BSP 1/2"	32.7	27.9	52.5	64.8	14	14	20	7.7
104.08 DGB 21-H4	8	BSP 1/2"	32.7	27.9	52.5	64.8	14	14	20	7.7
104.08 NGB 21	8	NPT 1/2"	32.7	27.9	52.5	64.8	14	14	20	7.7
104.08 NGB 21-H4	8	NPT 1/2"	32.7	27.9	52.5	64.8	14	14	20	7.7
104.12 DGB 26	12	BSP 3/4"	44	36.95	62.6	74.9	14	14	20	7.7
104.12 DGB 26-H4	12	BSP 3/4"	44	36.95	62.6	74.9	14	14	20	7.7
104.12 NGB 26	12	NPT 3/4"	44	36.95	62.6	74.9	14	14	20	7.7
104.12 NGB 26-H4	12	NPT 3/4"	44	36.95	62.6	74.9	14	14	20	7.7
104.15 DGB 26	15	BSP 3/4"	49	42.95	73	85.3	14	14	20	7.7
104.15 DGB 26-H4	15	BSP 3/4"	49	42.95	73	85.3	14	14	20	7.7
104.15 NGB 26	15	NPT 3/4"	49	42.95	73	85.3	14	14	20	7.7
104.15 NGB 26-H4	15	NPT 3/4"	49	42.95	73	85.3	14	14	20	7.7
104.20 DGB 33	20	BSP 1"	62	53.95	86.1	98.4	14	14	20	7.7
104.20 DGB 33-H4	20	BSP 1"	62	53.95	86.1	98.4	14	14	20	7.7
104.20 NGB 33	20	NPT 1"	62	53.95	86.1	98.4	14	14	20	7.7
104.20 NGB 33-H4	20	NPT 1"	62	53.95	86.1	98.4	14	14	20	7.7
104.25 DGB 42	25	BSP 1 1/4"	74	65.95	108.1	120.6	14	14	20	7.5
104.25 DGB 42-H4	25	BSP 1 1/4"	74	65.95	108.1	120.6	14	14	20	7.5
104.25 NGB 42	25	NPT 1 1/4"	74	65.95	108.1	120.6	14	14	20	7.5
104.25 NGB 42-H4	25	NPT 1 1/4"	74	65.95	108.1	120.6	14	14	20	7.5

PLUGS STECKNIPPEL

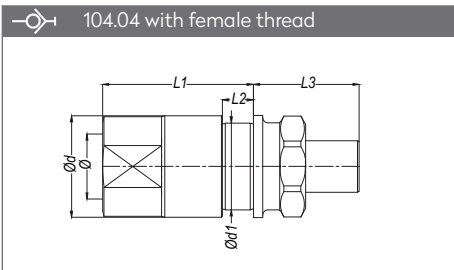

Part no.	DN	Ø	Ød	Ød1	L1		L2		L3	
					Standart Serie	MP Serie	Standart Serie	MP Serie	Standart Serie	MP Serie
104.04 DUB 13	4	BSP 1/4"	25	20.9	41	53	10	14	30.5	18.5
104.04 DUB 13-H4	4	BSP 1/4"	25	20.9	41	53	10	14	30.5	18.5
104.04 NUB 13	4	NPT 1/4"	25	20.9	41	53	10	14	30.5	18.5
104.04 NUB 13-H4	4	NPT 1/4"	25	20.9	41	53	10	14	30.5	18.5
104.06 DUB 17	6	BSP 3/8"	29	24.9	42.5	54.5	10	14	32	20
104.06 DUB 17-H4	6	BSP 3/8"	29	24.9	42.5	54.5	10	14	32	20
104.06 NUB 17	6	NPT 3/8"	29	24.9	42.5	54.5	10	14	32	20
104.06 NUB 17-H4	6	NPT 3/8"	29	24.9	42.5	54.5	10	14	32	20
104.08 DUB 21	8	BSP 1/2"	35.6	27.9	48.5	59.3	10	14	34	22
104.08 DUB 21-H4	8	BSP 1/2"	35.6	27.9	48.5	59.3	10	14	34	22
104.08 NUB 21	8	NPT 1/2"	35.6	27.9	48.5	59.3	10	14	34	22
104.08 NUB 21-H4	8	NPT 1/2"	35.6	27.9	48.5	59.3	10	14	34	22
104.12 DUB 26	12	BSP 3/4"	44	36.95	58.6	70.6	10	14	39	27
104.12 DUB 26-H4	12	BSP 3/4"	44	36.95	58.6	70.6	10	14	39	27
104.12 NUB 26	12	NPT 3/4"	44	36.95	58.6	70.6	10	14	39	27
104.12 NUB 26-H4	12	NPT 3/4"	44	36.95	58.6	70.6	10	14	39	27
104.15 DUB 26	15	BSP 3/4"	49	42.95	69	81	10	14	43	31
104.15 DUB 26-H4	15	BSP 3/4"	49	42.95	69	81	10	14	43	31
104.15 NUB 26	15	NPT 3/4"	49	42.95	69	81	10	14	43	31
104.15 NUB 26-H4	15	NPT 3/4"	49	42.95	69	81	10	14	43	31
104.20 DUB 33	20	BSP 1"	62	53.95	82.1	94.1	10	14	45.2	33.2
104.20 DUB 33-H4	20	BSP 1"	62	53.95	82.1	94.1	10	14	45.2	33.2
104.20 NUB 33	20	NPT 1"	62	53.95	82.1	94.1	10	14	45.2	33.2
104.20 NUB 33-H4	20	NPT 1"	62	53.95	82.1	94.1	10	14	45.2	33.2
104.25 DUB 42	25	BSP 1 1/4"	74	65.95	104.1	116.1	10	14	54.2	42.2
104.25 DUB 42-H4	25	BSP 1 1/4"	74	65.95	104.1	116.1	10	14	54.2	42.2
104.25 NUB 42	25	NPT 1 1/4"	74	65.95	104.1	116.1	10	14	54.2	42.2
104.25 NUB 42-H4	25	NPT 1 1/4"	74	65.95	104.1	116.1	10	14	54.2	42.2



DN 37-75

AUTOMATIC COUPLINGS
AUTOMATISCHE KUPPLUNGEN

SERIE 104

QUICK COUPLINGS SCHNELLKUPPLUNGEN

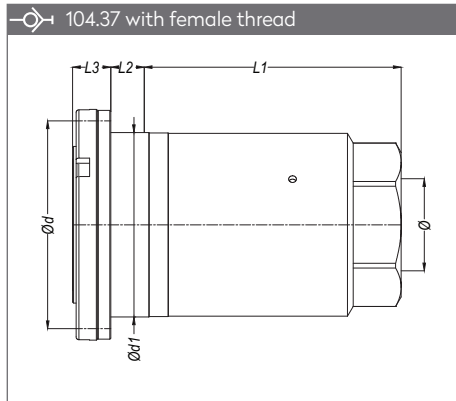

Part no.	DN	Ø	Ød	Ød1	L1	L2	L3
104.37 DGB 48	37	BSP 1 1/2"	108	95.8	135	16	20
104.37 NGB 48	37	NPT 1 1/2"	108	95.8	135	16	20
104.50 DGB 60	50	BSP 2"	136	124	162	16	20
104.50 NGB 60	50	NPT 2"	136	124	162	16	20
104.75 DGB 90	75	BSP 3"	183	171	223	16	20
104.75 NGB 90	75	NPT 3"	183	171	223	16	20

PLUGS STECKNIPPEL

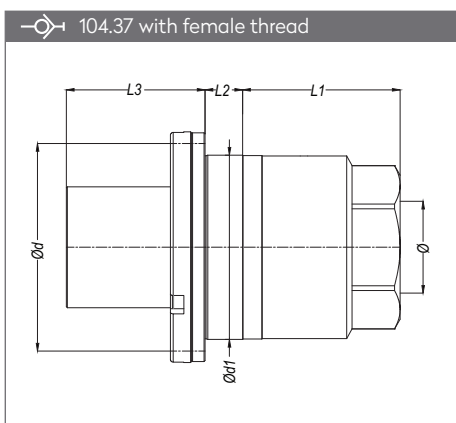

Part no.	DN	Ø	Ød	Ød1	L1	L2	L3
104.37 DUB 48	37	BSP 1 1/2"	108	95.8	101.5	16	72
104.37 NUB 48	37	NPT 1 1/2"	108	95.8	101.5	16	72
104.50 DUB 60	50	BSP 2"	136	124	106.2	16	85.8
104.50 NUB 60	50	NPT 2"	136	124	106.2	16	85.8
104.75 DUB 90	75	BSP 3"	183	171	160	16	120.8
104.75 NUB 90	75	NPT 3"	183	171	160	16	120.8

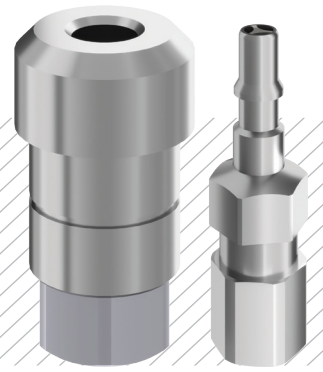

Materials

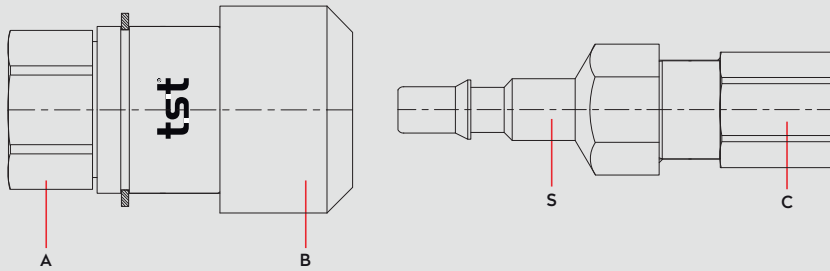

Material Code

A = AISI 303*
*Serie 105.03 - 105.06
A = Steel Zinc Plated*
*Serie 105.08 - 105.11 - 105.19
B = AISI 303*
*Serie 105.03 - 105.06 - 105.08 - 105.11
B = AISI 420*
*Serie 105.19
C = AISI 303
S = AISI 420

0 - 50 bar

-40°C to + 105°C (NBR)

Shut Off Type

DN

TST 105.03 → 3 mm
TST 105.06 → 6 mm
TST 105.08 → 8 mm
TST 105.11 → 11 mm
TST 105.19 → 19 mm

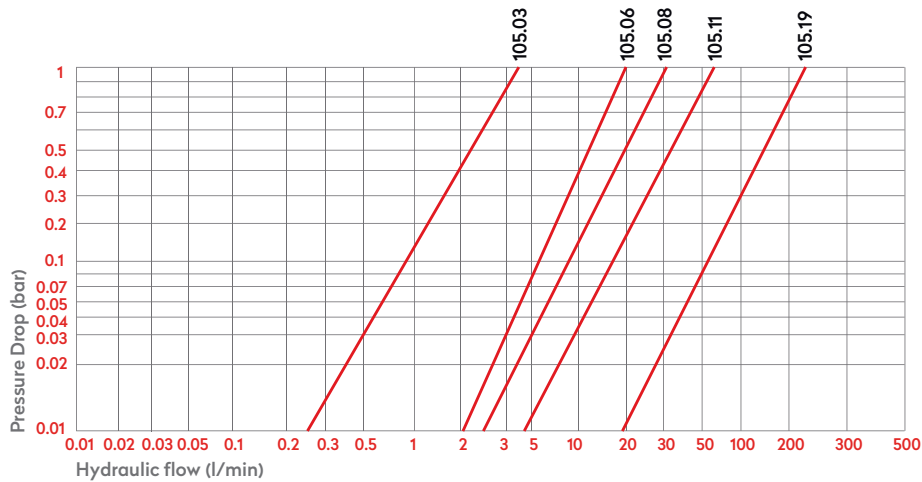

Options

FPM

AISI420
Stainless Steel

Applications

- Automatic multiconnections

Compatible with

AUTOMATIC COUPLINGS
 AUTOMATISCHE KUPPLUNGEN

SERIE 105



QUICK COUPLINGS SCHNELLKUPPLUNGEN

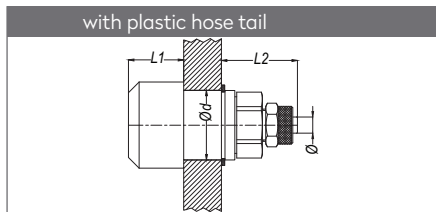
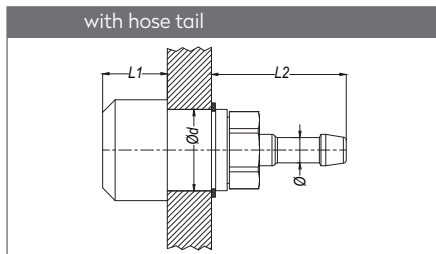
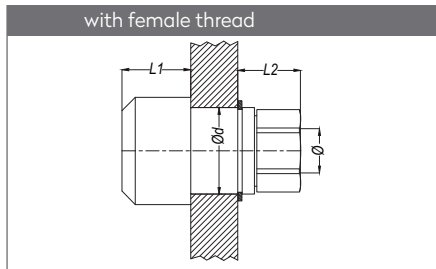

Double Shut-off	Single Shut-off	Full Flow	DN	Ø	Ød	L1	L2
105.03 DGB 10	105.03 DG 10	105.03 DGF 10	3	BSP 1/8"	15.9	9	19.5
105.06 DGB 10	105.06 DG 10	105.06 DGF 10	6	BSP 1/8"	25.9	20.5	15.2
105.06 DGB 13	105.06 DG 13	105.06 DGF 13	6	BSP 1/4"	25.9	18.5	18.2
105.08 DGB 17	105.08 DG 17	105.08 DGF 17	8	BSP 3/8"	31.85	20	31
105.08 DGB 21	105.08 DG 21	105.08 DGF 21	8	BSP 1/2"	31.85	20	40
105.11 DGB 17	105.11 DG 17	105.11 DGF 17	11	BSP 3/8"	37.9	14.4	47.6
105.11 DGB 21	105.11 DG 21	105.11 DGF 21	11	BSP 1/2"	37.9	14.4	49.6
105.19 DGB 26	105.19 DG 26	105.19 DGF 26	19	BSP 3/4"	53.9	9	75.8
105.19 DGB 33	105.19 DG 33	105.19 DGF 33	19	BSP 1"	53.9	9	75.8

Double Shut-off	Single Shut-off	Full Flow	DN	Ø	Ød	L1	L2
105.03 HGB 04	105.03 HG 04	105.03 HGF 04	3	Ø4	15.9	9	33.5
105.06 HGB 06	105.06 HG 06	105.06 HGF 06	6	Ø6	25.9	20.5	42.2
105.11 HGB 13	105.11 HG 13	105.11 HGF 13	11	Ø13	37.9	14.4	76.6
105.19 HGB 19	105.19 HG 19	105.19 HGF 19	19	Ø19	53.9	9	114.8

Double Shut-off	Single Shut-off	Full Flow	DN	Ø	Ød	L1	L2
105.03 PGB 04	105.03 PG 04	105.03 PGF 04	3	4x6 mm-M10x1	15.9	9	23.5
105.06 PGB 06	105.06 PG 06	105.06 PGF 06	6	6x8 mm-M12x1	25.9	20.5	27.7
105.08 PGB 08	105.08 PG 08	105.08 PGF 08	8	8x10 mm-M20x1.5	31.85	20	47.5

PLUGS STECKNIPPEL

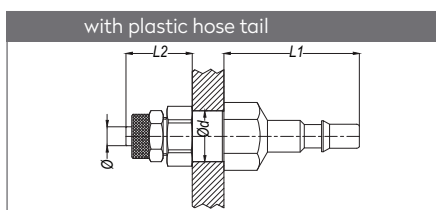
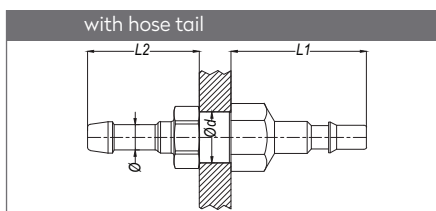
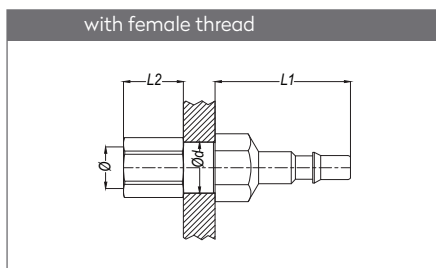

Double Shut-off	Full Flow	DN	Ø	Ød	L1	L2
105.03 DUB 10	105.03 DUF 10	3	BSP 1/8"	16	29	20.7
105.06 DUB 10	105.06 DUF 10	6	BSP 1/8"	16.15	43	16
105.06 DUB 13	105.06 DUF 13	6	BSP 1/4"	16.15	43	19
105.08 DUB 13	105.08 DUF 13	8	BSP 1/4"	21.4	52	20
105.08 DUB 17	105.08 DUF 17	8	BSP 3/8"	21.4	52	22
105.08 DUB 21	105.08 DUF 21	8	BSP 1/2"	21.4	52	27
105.11 DUB 21	105.11 DUF 21	11	BSP 1/2"	26.3	62.5	21.5
105.19 DUB 26	105.19 DUF 26	19	BSP 3/4"	39	88	29.5
105.19 DUB 33	105.19 DUF 33	19	BSP 1"	39	88	37.5

Double Shut-off	Full Flow	DN	Ø	Ød	L1	L2
105.03 HUB 04	105.03 HUF 04	3	Ø4	16	29	34.7
105.06 HUB 06	105.06 HUF 06	6	Ø6	16.15	43	35.5
105.08 HUB 08	105.08 HUF 08	8	Ø8	21.4	52	34.5
105.11 HUB 13	105.11 HUF 13	11	Ø13	26.3	62.5	42
105.19 HUB 19	105.19 HUF 19	19	Ø19	39	88	73.5

Double Shut-off	Full Flow	DN	Ø	L1	L2	Ød
105.03 PUB 04	105.03 PUF 04	3	4x6 mm-M10x1	29	24.7	16
105.06 PUB 06	105.06 PUF 06	6	6x8 mm-M12x1	43	21	16.15
105.08 PUB 08	105.08 PUF 08	8	8x10 mm-M20x1.5	52	27.5	21.4

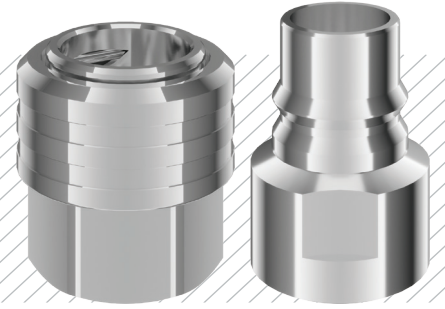

Materials

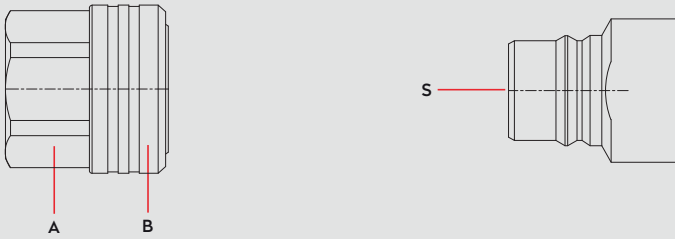

Material Code

A = Brass Chrome Plated

B = Brass Chrome Plated

S = AISI 420 / Chrome Plated



0 - 10 bar



-40° to + 105°C (NBR)

Shut Off Type



 <p>COUPLING</p>	<u>TST 106.25</u>	<u>TST 106.38</u>	<u>TST 106.50</u>
	OM 353 - 02975	OM 353 - 03810	OM 534 - 05650

DN

TST 106.25 → 25 mm
TST 106.33 → 33 mm
TST 106.50 → 50 mm

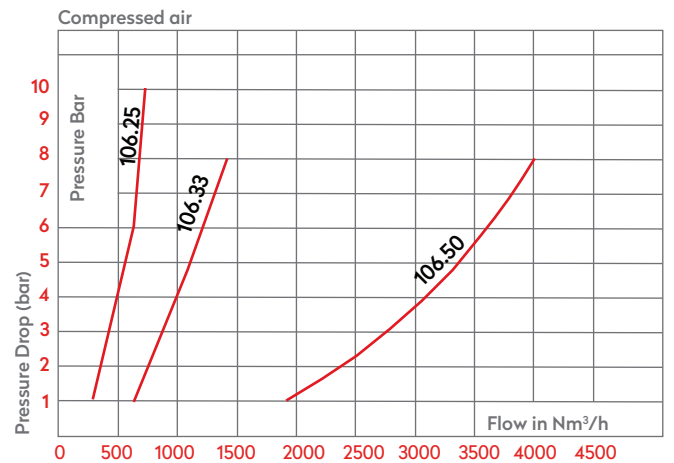
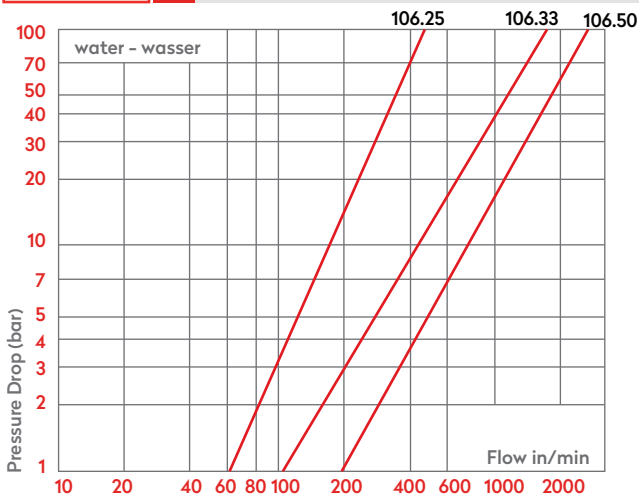

Options

FPM  EPDM  AISI316 

Serie 106.25 Serie 106.25

Applications

- Compressed air circuits
- Water connections

Compatible with

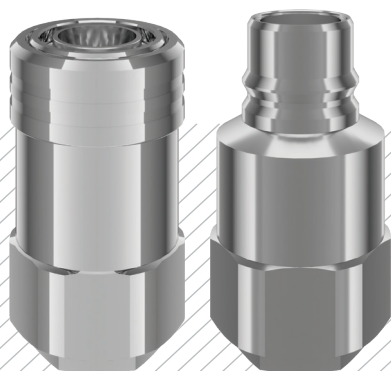
 MOULD COOLING COUPLINGS
 KÜHLUNGSELEMENTE FÜR WERKZEUGE

SERIE 106

QUICK COUPLINGS SCHNELLKUPPLUNGEN

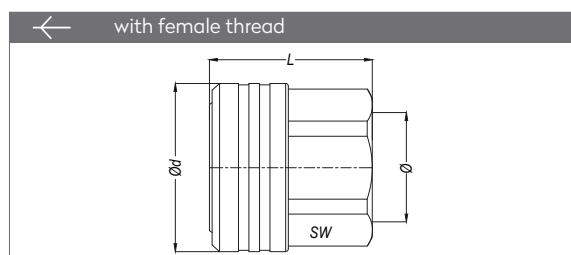

Part No.	DN	Ø	Ød	L	SW
106.25 DGF 33	25	BSP 1"	57	57	46
106.33 DGF 42	33	BSP 1 1/4"	64	62	55
106.50 DGF 60	50	BSP 2"	89	70	77

VALVED QUICK COUPLINGS SCHNELLKUPPLUNGEN MIT VENTIL

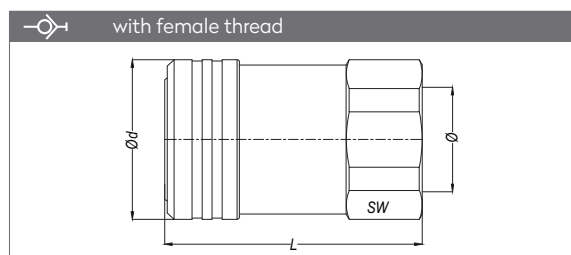

Part No.	DN	Ø	Ød	L	SW
106.33 DGB 33	33	BSP 1"	64	111.3	111.3
106.33 DGB 42	33	BSP 1 1/4"	64	103.3	103.3

ACCESSORIES ZUBEHÖR

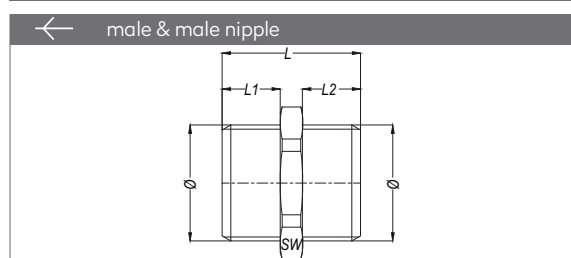

Part No.	DN	Ø	L	L1	L2	SW
EE 33-33K	25	BSP 1"	46	19	19	41
EE 42-42K	33	BSP 1 1/4"	52	21	21	50
EE 60-60K	50	BSP 2"	65	25	25	70

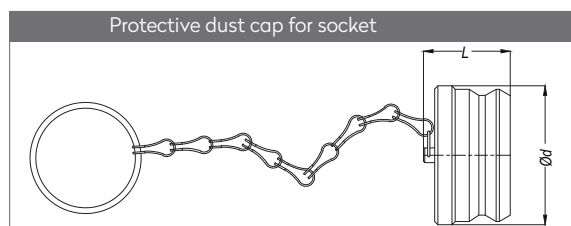

Part No.	DN	Ø	Ød	L
106.25 KG 00	25	BSP 1"	35	26.2
106.33 KG 00	33	BSP 1 1/4"	44	27.2
106.50 KG 00	50	BSP 2"	64	27.2

PLUGS STECKNIPPEL

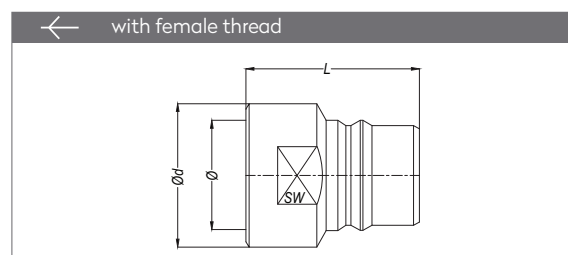

Part No.	DN	Ø	Ød	L	SW
106.25 DU 33	25	BSP 1"	44.6	61	41
106.33 DU 42	33	BSP 1 1/4"	54.6	66	50
106.50 DU 60	50	BSP 2"	74.6	78	71

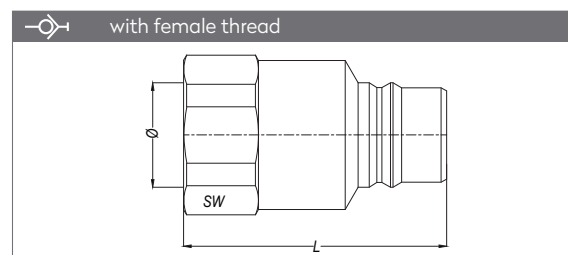

Part No.	DN	Ø	L	SW
106.33 DUB 33	33	BSP 1"	113.5	60
106.33 DUB 42	33	BSP 1 1/4"	105.5	60

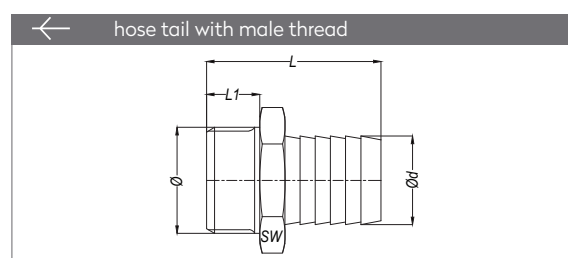

Part No.	DN	Ø	Ød	L	L1	SW
106.25 TAF 25	25	BSP 1"	28	69	21	40
106.25 TAF 33	25	BSP 1"	35	69	21	40
106.33 TAF 32	33	BSP 1 1/4"	35	69	21	50
106.33 TAF 42	33	BSP 1 1/4"	41	69	21	50
106.50 TAF 51	50	BSP 2"	54	85	25	70
106.50 TAF 60	50	BSP 2"	61	85	25	70



Materials

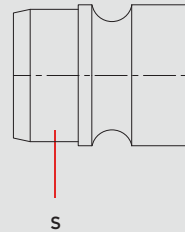
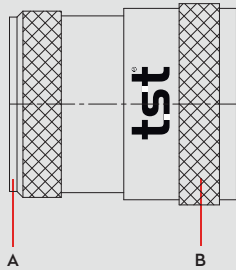

Material Code

- A = Brass Chrome Plated
- B = Brass Chrome Plated
- S = Brass Chrome Plated



0 - 35 bar



-40°C to + 105°C (NBR)

Shut Off Type



OM 262 - 01510
CON - 1900 - 1400 - 20
OM200 - 00800

FULL FLOW

DN

11 mm

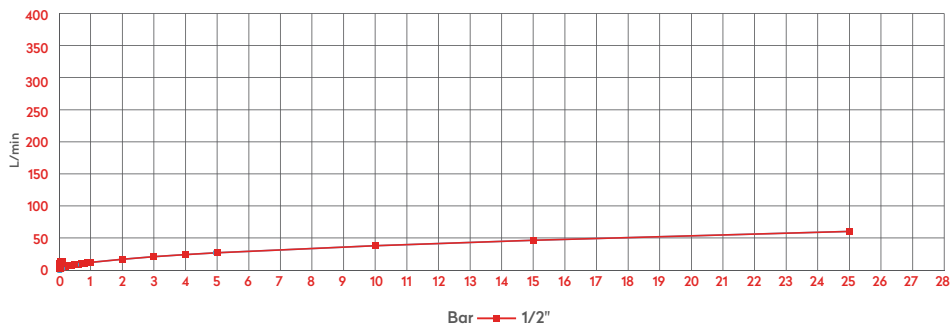

Options

FPM



AISI316
Stainless Steel

Plug Profile Serie 110

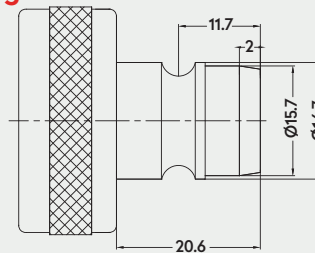

Compatible with

DYROS 100
NITO 1/2" (5350)

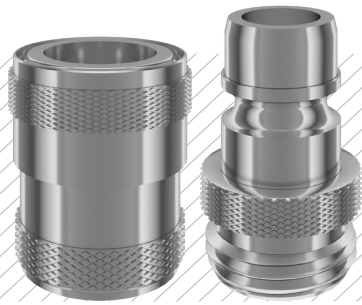

QUICK COUPLINGS SCHNELLKUPPLUNGEN

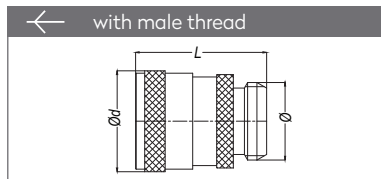

Part No.	Ø	Ød	L
110 EGF 17	BSP 3/8"	27.3	34.5
110 EGF 21	BSP 1/2"	27.3	35.5
110 EGF 26	BSP 3/4"	27.3	35.5
110 EGFM 22	M 22 x 1.5	27.3	35.5

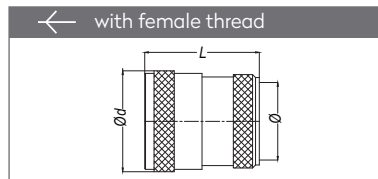

Part No.	Ø	Ød	L
110 DGF 17	BSP 3/8"	27.3	31
110 DGF 21	BSP 1/2"	27.3	31
110 DGF 26	BSP 3/4"	27.3	33
110 DGFM 22	M 22 x 1.5	27.3	31

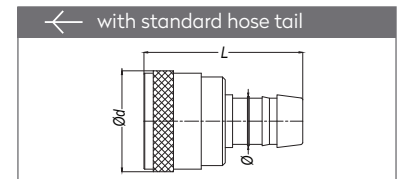

Part No.	Ø	Ød	L
110 HGF 10	Ø 10 mm - 3/8"	27.3	43
110 HGF 13	Ø 13 mm - 1/2"	27.3	43
110 HGF 16	Ø 16 mm - 5/8"	27.3	43
110 HGF 19	Ø 19 mm - 3/4"	27.3	43

PLUGS STECKNIPPEL

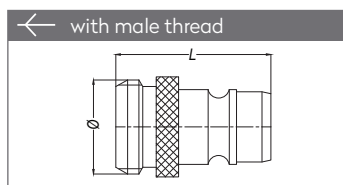

Part No.	Ø	L
110 EU 17	BSP 3/8"	34.6
110 EU 21	BSP 1/2"	34.6
110 EU 26	BSP 3/4"	34.6
110 EUM 22	M 22 x 1	34.6
110 EUM 24	M 24 x 1	37.6
110 EUM 28	M 28 x 1	37.6

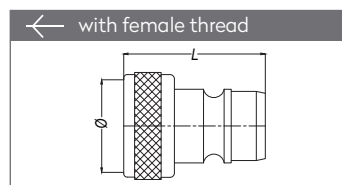

Part No.	Ø	L
110 DU 17	BSP 3/8"	30
110 DU 21	BSP 1/2"	32.1
110 DU 26	BSP 3/4"	33.6
110 DUM 22-1	M 22 x 1	30
110 DUM 24	M 24 x 1	31.6
110 DUM 22	M 22 x 1.5	32.1

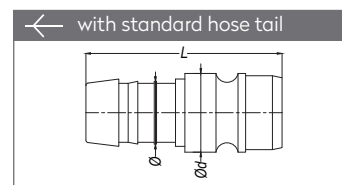

Part No.	Ø	Ød	L
110 HU 10	Ø 10 mm - 3/8"	16.7	41.6
110 HU 13	Ø 13 mm - 1/2"	16.7	41.6
110 HU 16	Ø 16 mm - 5/8"	17	41.6
110 HU 19	Ø 19 mm - 3/4"	20	41.6

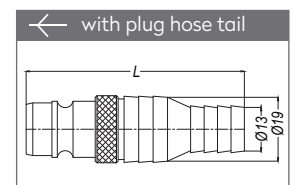

Part No.	Ø	L
110 HU 13/19	Ø 13 - Ø 19	65

ACCESSORIES ZUBEHÖR

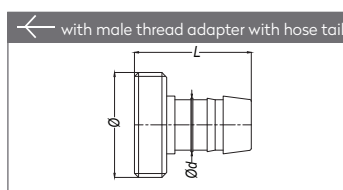

Part No.	Ø	Ød	L
110 GU 13	BSP 3/4"	Ø19	29
110 GU 19	BSP 3/4"	Ø19	29

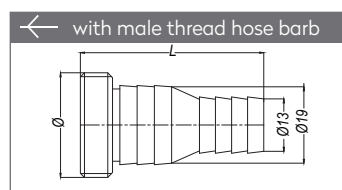

Part No.	Ø	Ød-Ød1	L
110 GU 13/19	BSP 3/4"	Ø13-19	45.6

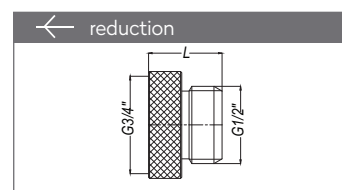

Part No.	Ø	L
110 RD 21	BSP 3/4" - 1/2"	20

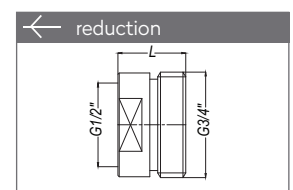

Part No.	Ø	L
110 RD 26	BSP 1/2" - 3/4"	17

CHECK VALVE RÜCKSCHLAGVENTILE

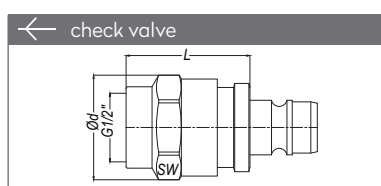

Part No.	Ø	Ød	L	SW
110 CVD 21	BSP 1/2"	32	37.9	30

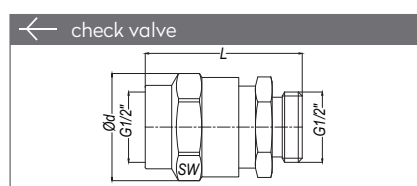

Part No.	Ø	Ød	L	SW
110 CVD 21 - E 21	BSP 1/2" - BSP 1/2"	32	47	30

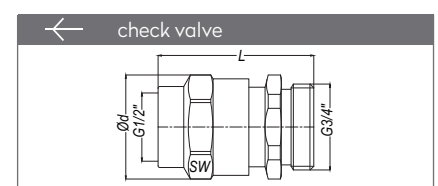

Part No.	Ø	Ød	L	SW
110 CVD 21 - E 26	BSP 3/4" - BSP 1/2"	32	47.9	30



Materials

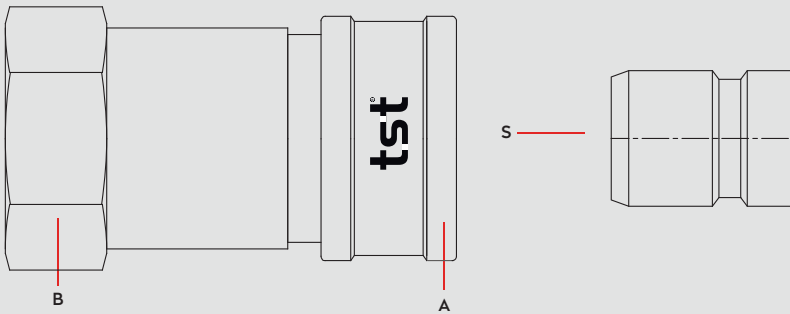

Material Code

- A = Brass Nickel Plated
- B = Brass Nickel Plated
- S = Brass Nickel Plated



0 - 10 bar



-40° to + 105°C (NBR)

Options

AISI316
Stainless Steel



TST 112.12
OM 262 - 01510
OM 200 - 00800 (valved)
TST 112.19
OM 353 - 02340
OM 200 - 03000 (valved)
07219VC00M (valved)

Shut Off Type



DN

12 - 19 mm

Plug Profile Serie 112

■ 112.12

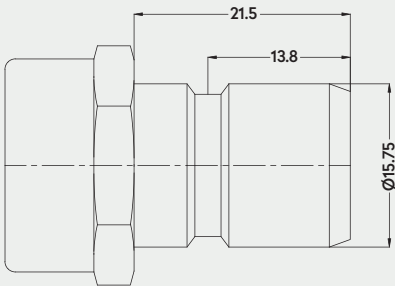

■ 112.19

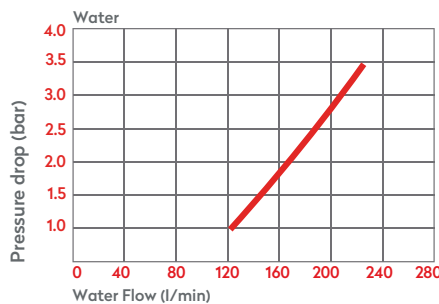
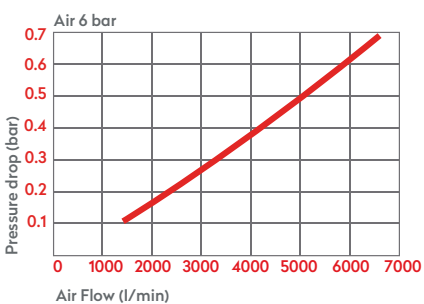
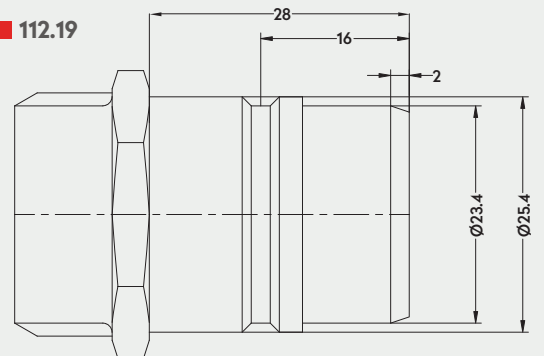

Compatible with

PARKER - LEGRIS Ø12 - Ø19

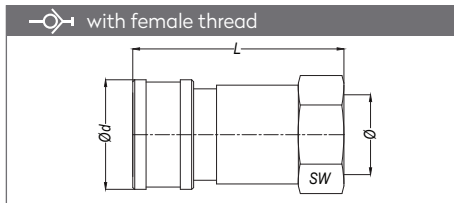
VALVED QUICK COUPLINGS SCHNELLKUPPLUNGEN MIT VENTIL

Part No.	Ø	SW	L	Ød
112.12 DG 17	BSP 3/8"	27	55.5	28.8
112.12 DG 21	BSP 1/2"	27	55.5	28.8

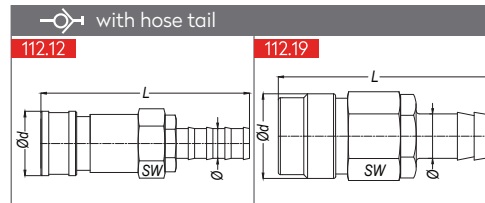

Part No.	Ø	SW	L	Ød
112.12 HG 13	Ø13	27	87.7	28.8
112.12 HG 15	Ø15	27	87.7	28.8
112.12 HG 19	Ø19	27	93.3	28.8
112.19 HG 19	Ø19	36	90.5	39.6

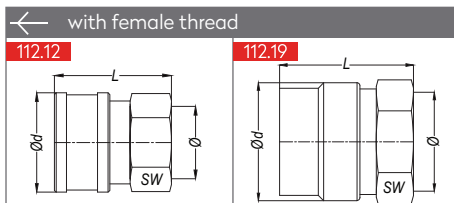
UNVALVED QUICK COUPLINGS SCHNELLKUPPLUNGEN OHNE VENTIL

Part No.	Ø	SW	L	Ød
112.12 DGF 17	BSP 3/8"	24	34	28.8
112.12 DGF 21	BSP 1/2"	24	34	28.8
112.12 DGF 26	BSP 3/4"	30	38	28.8
112.12 DGF 33	BSP 1"	36	40	28.8
112.19 DGF 33	BSP 1"	36	45	39.6

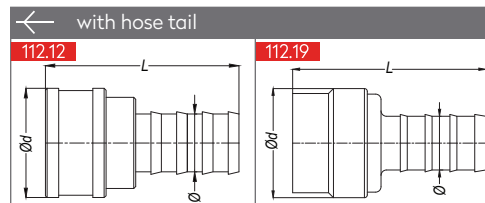

Part No.	Ø	L	Ød
112.12 HGF 12	Ø12	51	28.8
112.12 HGF 15	Ø15	51	28.8
112.12 HGF 19	Ø19	57	28.8
112.19 HGF 19	Ø19	70	39.6
112.19 HGF 25	Ø25	70	39.6

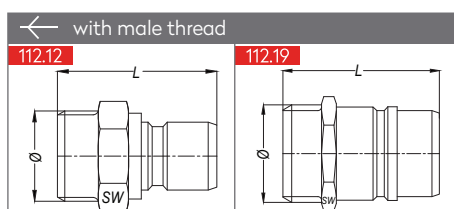
PLUGS STECKNIPPEL

Part No.	Ø	SW	L
112.12 EU 17	BSP 3/8"	22	31.5
112.12 EU 21	BSP 1/2"	22	37
112.12 EU 26	BSP 3/4"	27	41
112.12 EU 33	BSP 1"	35	41
112.19 EU 26	BSP 3/4"	27	42.5
112.19 EU 33	BSP 1"	35	46

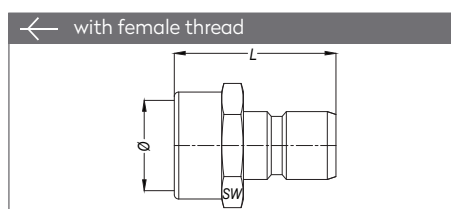

Part No.	Ø	SW	L
112.12 DU 13	BSP 1/4"	17	37.5
112.12 DU 17	BSP 3/8"	21	37.5
112.12 DU 21	BSP 1/2"	25	37.5
112.12 DU 26	BSP 3/4"	32	42.5
112.12 DU 33	BSP 1"	38	45.5

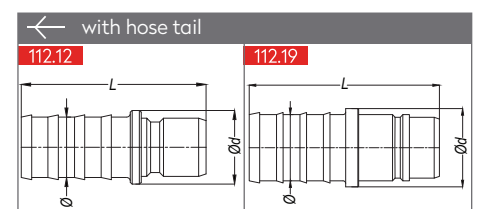

Part No.	Ø	L	Ød
112.12 HU 07	Ø7	54	17
112.12 HU 10	Ø10	54	17
112.12 HU 12	Ø12	50	17
112.12 HU 13	Ø13	54	17
112.12 HU 15	Ø15	50	18
112.12 HU 16	Ø16	50	20
112.12 HU 19	Ø19	57.5	21
112.19 HU 19	Ø19	69	25.3
112.19 HU 25	Ø25	73	30

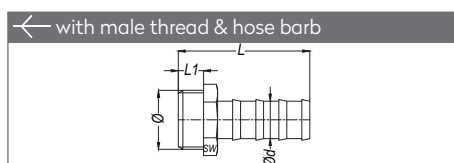

Part No.	Ø	Ød	SW	L	L1
112.12 GU 12	BSP 1/2"	Ø12	22	41.2	9
112.12 GU 13	BSP 1/2"	Ø13	22	41.2	9
112.12 GU 15	BSP 1/2"	Ø15	22	41.2	9
112.12 GU 19	BSP 1/2"	Ø19	22	46.8	9
112.12 GU 21	BSP 1/2"	Ø21	24	46.8	9

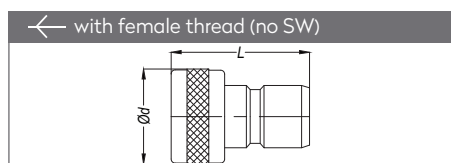

Part No.	Ø	L	Ød
112.12 DN 17	BSP 3/8"	32	20
112.12 DN 21	BSP 1/2"	35	24
112.12 DN 26	BSP 3/4"	39	32
112.12 DN 33	BSP 1"	44	39

DN 15-20

SERIE 116



Materials

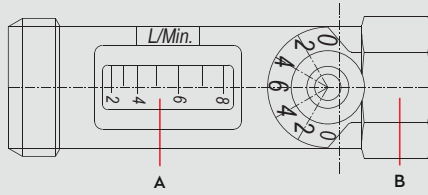

Material Code

A = Plexiglass

B = Brass



0 - 10 bar



-40° to + 105°C (NBR)

Shut Off Type



TST 116.08

OM200 - 1300
OM178 - 01280
OM150 - 00200

TST 116.10 / 116.12

OM 157 - 00400
OM 178 - 01955
OM 178 - 01480

FLOW

TST 116.08

Minimum → 2 lt/min
Maximum → 8 lt/min

TST 116.10/116.12

Minimum → 8 lt/min
Maximum → 30 lt/min

DN 15 - 20 mm

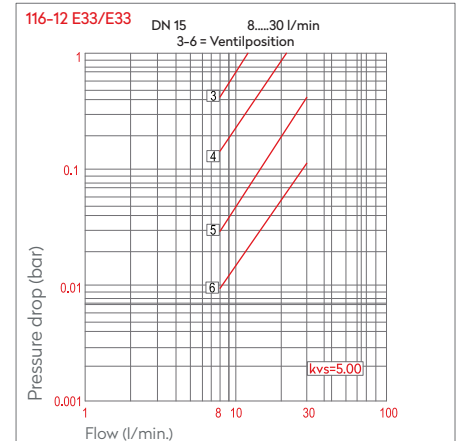
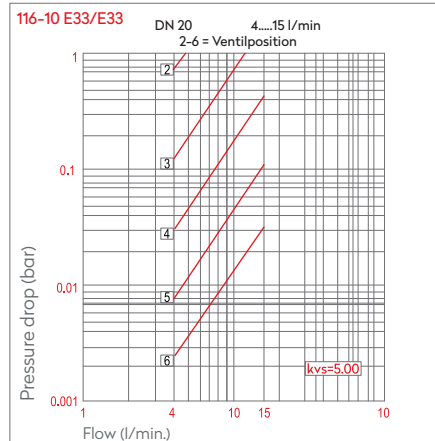
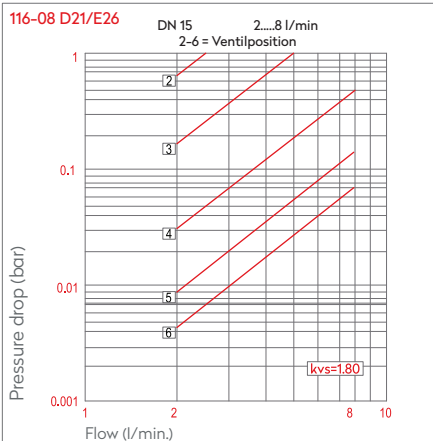

SERIE 116



FLOW METER FLUßMETER

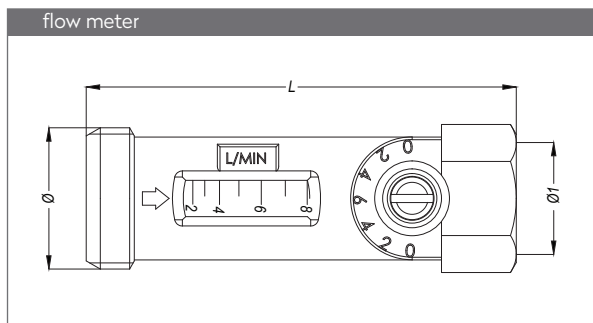

Part No.	Ø1	Ø	SW	L
	Female (F)	Male (M)		
116-08 D21/E26	BSP 1/2"	BSP 3/4"	24	80.5

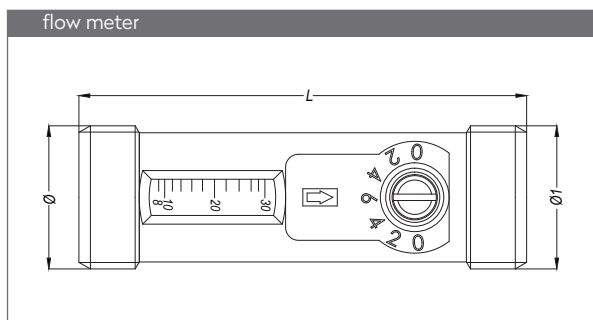

Part No.	Ø1	Ø	SW	L
	Male (M)	Male (M)		
116-10 E33/E33	BSP 1"	BSP 1"	30	104
116-12 E33/E33	BSP 1"	BSP 1"	30	104

SERIE 117K - 117KA - 117AK

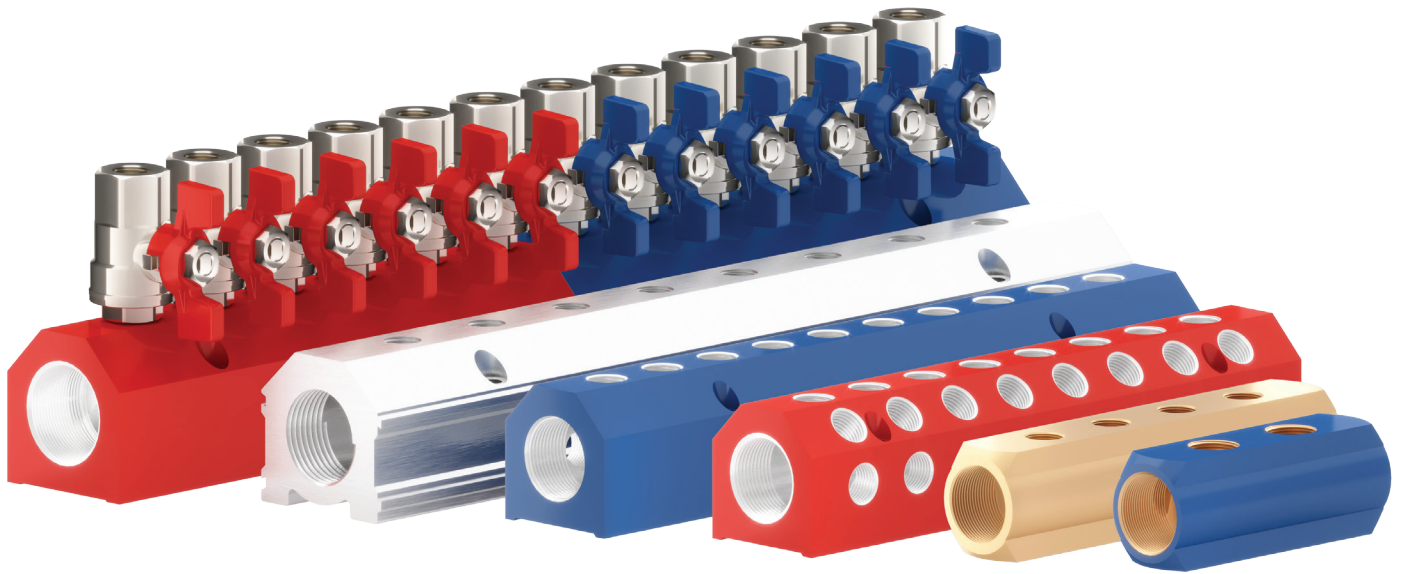

SERIE 117K

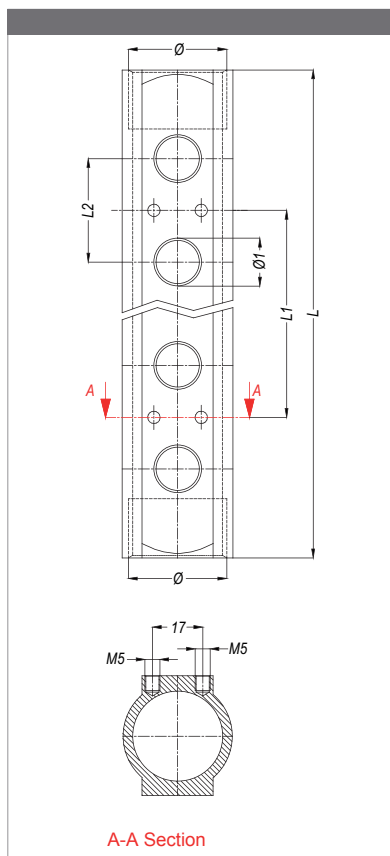
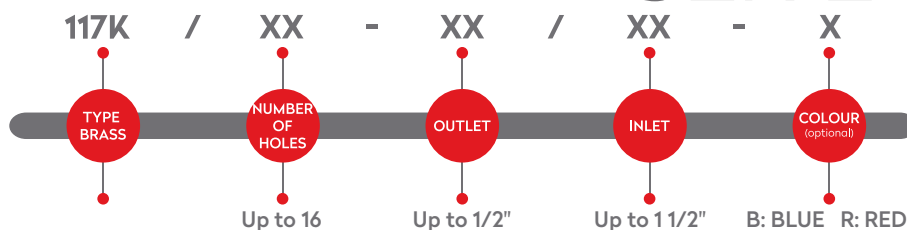
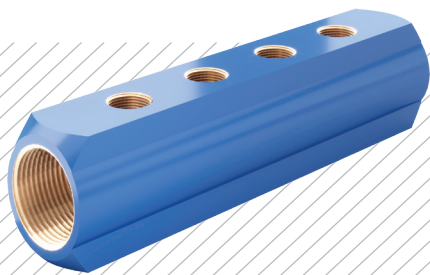

Ø1 = OUTLET = 1/4"		Ø = INLET = 3/4"		
Number of Holes	Part No.	L	L2	L1
3	117K-03-13/26	120	30	70
4	117K-04-13/26	150	30	70
5	117K-05-13/26	180	30	70
6	117K-06-13/26	210	30	70
7	117K-07-13/26	240	30	70
8	117K-08-13/26	270	30	70
9	117K-09-13/26	300	30	70
10	117K-10-13/26	330	30	70
11	117K-11-13/26	360	30	70

Ø1 = OUTLET = 3/8"		Ø = INLET = 3/4"		
Number of Holes	Part No.	L	L2	L1
4	117K-04-17/26	165	35	70
5	117K-05-17/26	200	35	70
6	117K-06-17/26	235	35	70
8	117K-08-17/26	305	35	70
10	117K-10-17/26	375	35	70
12	117K-12-17/26	445	35	70

Ø1 = OUTLET = 3/8"		Ø = INLET = 1"		
Number of Holes	Part No.	L	L2	L1
4	117K-04-17/33	165	35	70
5	117K-05-17/33	200	35	70
6	117K-06-17/33	235	35	70
8	117K-08-17/33	305	35	70
10	117K-10-17/33	375	35	70
12	117K-12-17/33	445	35	70

Ø1 = OUTLET = 1/2"		Ø = INLET = 1"		
Number of Holes	Part No.	L	L2	L1
4	117K-04-21/33	210	50	70
5	117K-05-21/33	260	50	70
6	117K-06-21/33	310	50	70
8	117K-08-21/33	410	50	70
10	117K-10-21/33	510	50	70
12	117K-12-21/33	610	50	70

Ø1 = OUTLET = 3/8"		Ø = INLET = 1 1/4"		
Number of Holes	Part No.	L	L2	L1
4	117K-04-17/42	196	40	150
5	117K-05-17/42	236	40	150
6	117K-06-17/42	276	40	150
8	117K-08-17/42	356	40	150
10	117K-10-17/42	436	40	150
12	117K-12-17/42	516	40	150
16	117K-16-17/42	676	40	150

Ø1 = OUTLET = 1/2"		Ø = INLET = 1 1/4"		
Number of Holes	Part No.	L	L2	L1
4	117K-04-21/42	226	50	150
5	117K-05-21/42	276	50	150
6	117K-06-21/42	326	50	150
8	117K-08-21/42	426	50	150
10	117K-10-21/42	526	50	150
12	117K-12-21/42	626	50	150

Ø1 = OUTLET = 3/8"		Ø = INLET = 1 1/2"		
Number of Holes	Part No.	L	L2	L1
4	117K-04-17/48	196	40	150
5	117K-05-17/48	236	40	150
6	117K-06-17/48	276	40	150
8	117K-08-17/48	356	40	150
10	117K-10-17/48	436	40	150
12	117K-12-17/48	516	40	150
16	117K-16-17/48	676	40	150

Ø1 = OUTLET = 1/2"		Ø = INLET = 1 1/2"		
Number of Holes	Part No.	L	L2	L1
4	117K-04-21/48	226	50	150
5	117K-05-21/48	276	50	150
6	117K-06-21/48	326	50	150
8	117K-08-21/48	426	50	150
10	117K-10-21/48	526	50	150
12	117K-12-21/48	626	50	150

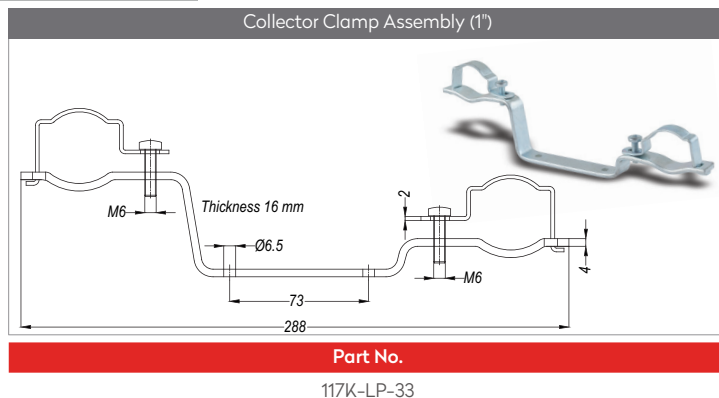
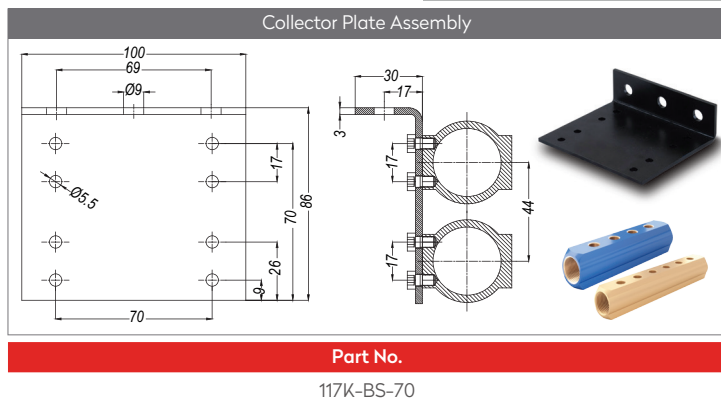

SERIE 117KA

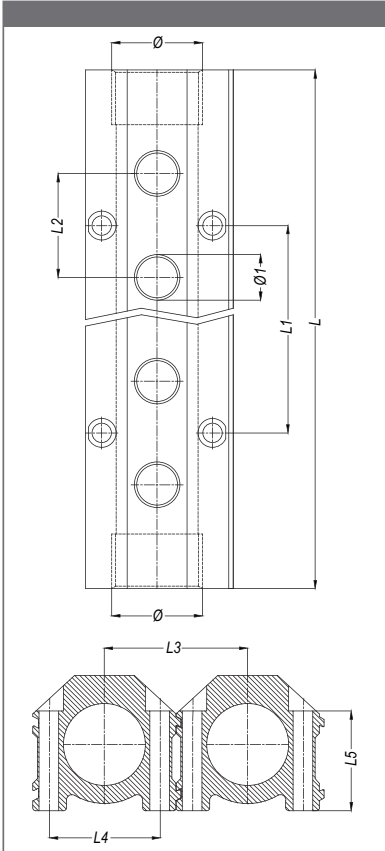
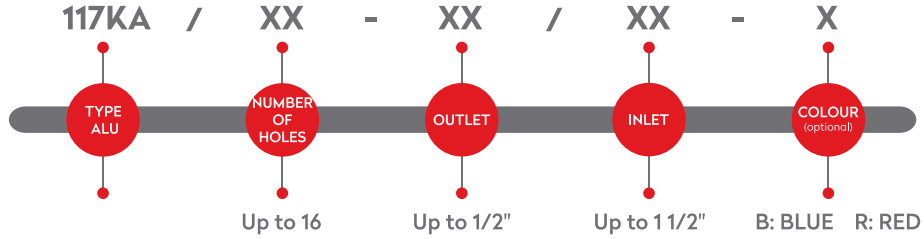
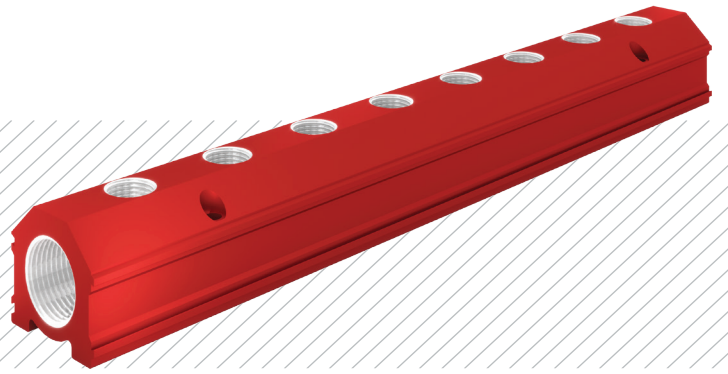

Number of Holes	Part No.	Ø1 = OUTLET = 1/4" Ø = INLET = 3/4"			Ø1 = OUTLET = 3/8" Ø = INLET = 3/4"		
		L	L1	L2	L3	L4	L5
4	117KA-04-13/26	190	76	38	45	31	30
6	117KA-06-13/26	266	152	38	45	31	30
8	117KA-08-13/26	342	228	38	45	31	30
10	117KA-10-13/26	418	304	38	45	31	30

Number of Holes	Part No.	Ø1 = OUTLET = 1/4" Ø = INLET = 1"			Ø1 = OUTLET = 3/8" Ø = INLET = 1"		
		L	L1	L2	L3	L4	L5
4	117KA-04-17/26	190	76	38	53	31	30
6	117KA-06-17/26	266	152	38	53	31	30
8	117KA-08-17/26	342	228	38	53	31	30
10	117KA-10-17/26	418	304	38	53	31	30

Number of Holes	Part No.	Ø1 = OUTLET = 1/4" Ø = INLET = 1"			Ø1 = OUTLET = 3/8" Ø = INLET = 1"		
		L	L1	L2	L3	L4	L5
4	117KA-04-13/33	190	76	38	53	40.6	36.5
6	117KA-06-13/33	266	152	38	53	40.6	36.5
8	117KA-08-13/33	342	228	38	53	40.6	36.5
10	117KA-10-13/33	418	304	38	53	40.6	36.5
12	117KA-12-13/33	494	380	38	53	40.6	36.5
16	117KA-16-13/33	646	532	38	53	40.6	36.5

Number of Holes	Part No.	Ø1 = OUTLET = 1/4" Ø = INLET = 1"			Ø1 = OUTLET = 3/8" Ø = INLET = 1"		
		L	L1	L2	L3	L4	L5
4	117K-04-17/33	229	102	51	53	40.6	36.5
6	117K-06-17/33	331	204	51	53	40.6	36.5
8	117K-08-17/33	433	306	51	53	40.6	36.5
10	117K-10-17/33	535	408	51	53	40.6	36.5
12	117K-12-17/33	637	510	51	53	40.6	36.5
16	117K-16-17/33	841	714	51	53	40.6	36.5

Number of Holes	Part No.	Ø1 = OUTLET = 1/2" Ø = INLET = 1"			Ø1 = OUTLET = 3/8" Ø = INLET = 1"		
		L	L1	L2	L3	L4	L5
4	117KA-04-21/33	229	102	51	53	40.6	36.5
6	117KA-06-21/33	331	204	51	53	40.6	36.5
8	117KA-08-21/33	433	306	51	53	40.6	36.5
10	117KA-10-21/33	535	408	51	53	40.6	36.5
12	117KA-12-21/33	637	510	51	53	40.6	36.5

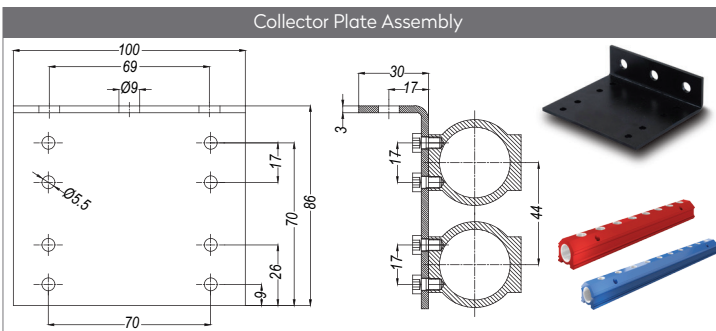

Part No.
117K-BS-70
1 1/4" & 1 1/2" available

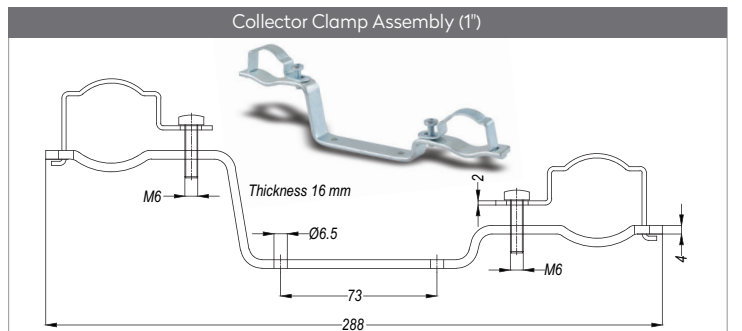

Part No.
117K-LP-33

SERIE 117AK

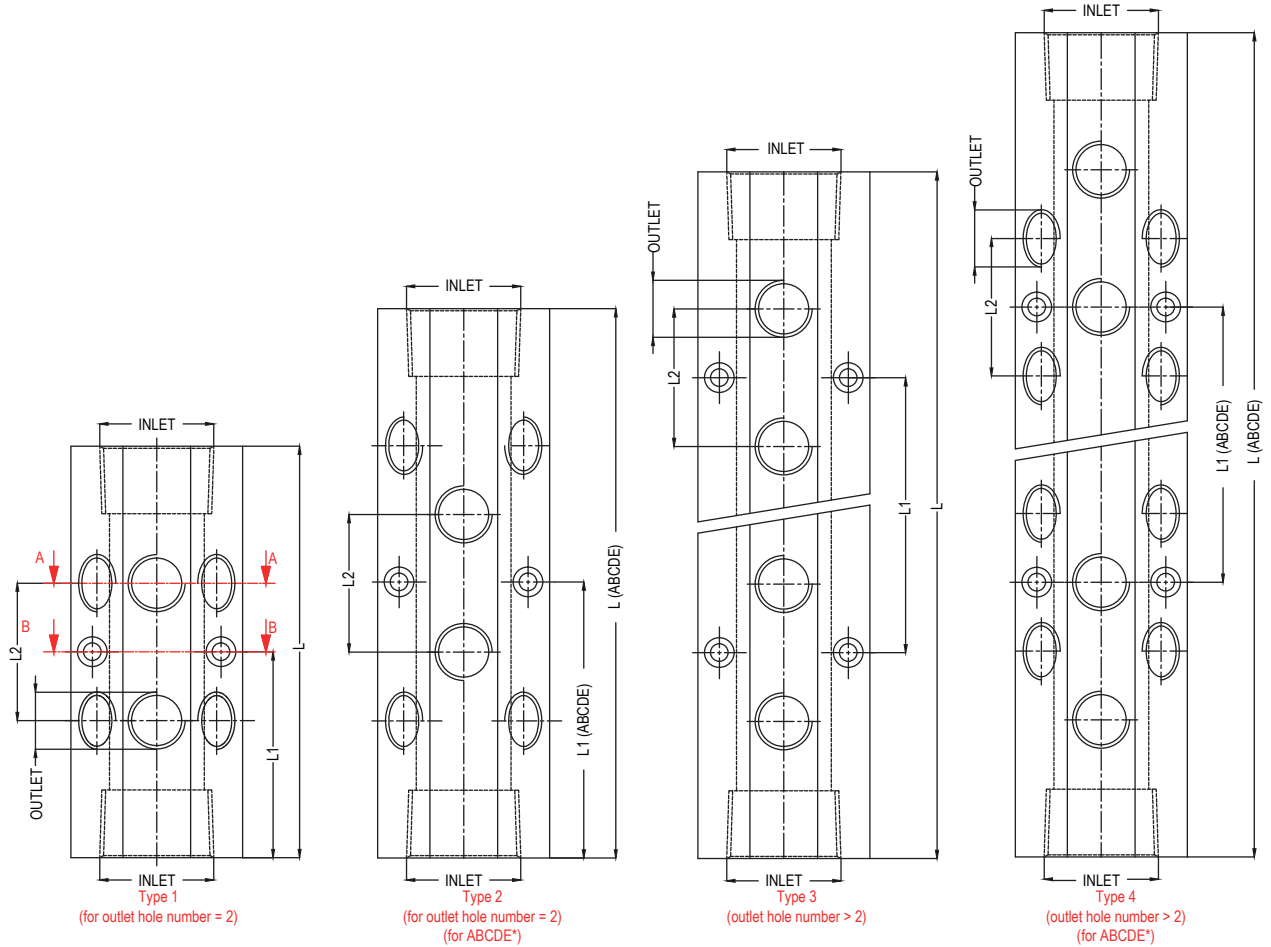
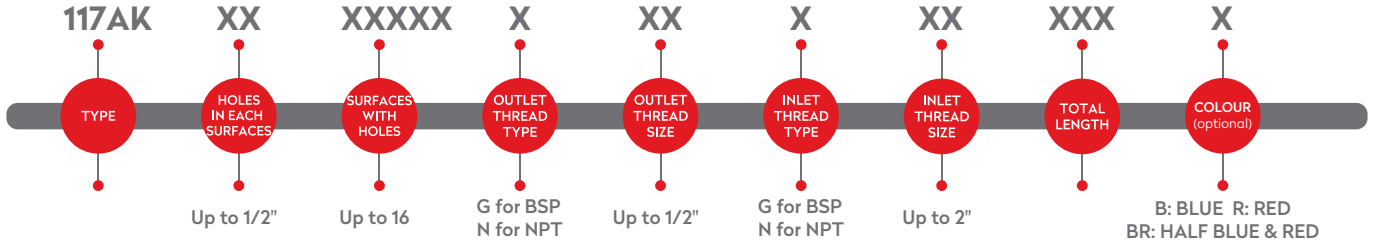
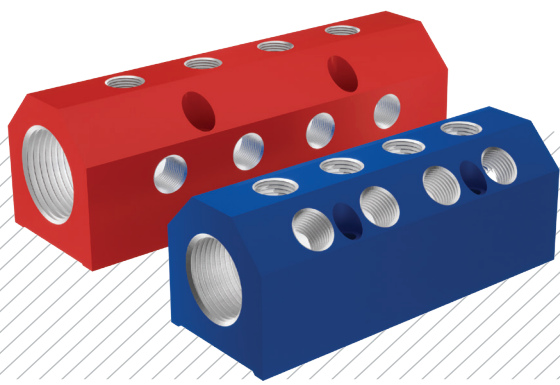

A-A Section

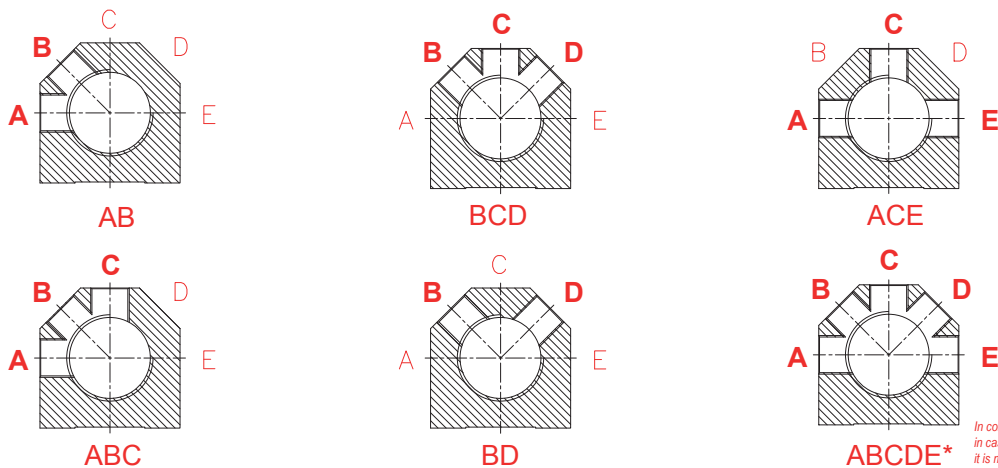

In collectors with teeth on 5 surfaces, in case the tooth lengths do not save, it is made by shifting as in Type 2 & Type 4.

SERIE 117AK

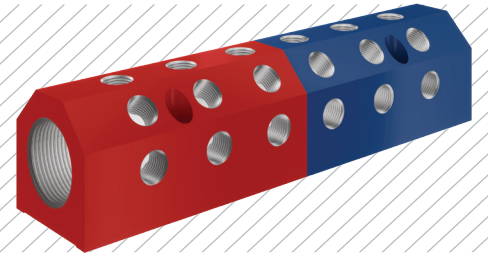

B-B Section

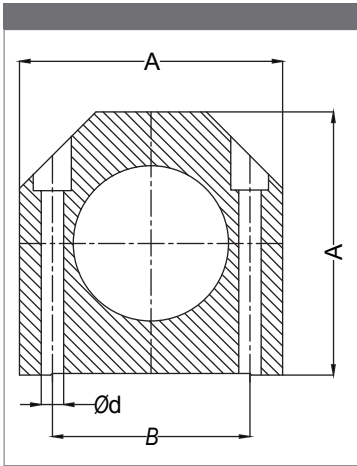

INLET	A	B	Ød
3/4"	44.5	35	5
1"	50.8	38.1	6.5
1-1/4"	63.5	47.6	6.5
1-1/2"	76.2	57.2	6.5
2"	89	72.4	6.5

INLET: 3/4"

Number of Holes	Ø1 = OUTLET = 1/4" & 3/8"			Ø = INLET = 3/4"	
	L	L1	L (ABCDE) <small>Type 2 & 4</small>	L1 (ABCDE) <small>Type 2 & 4</small>	L2
2	95	47.5	95	47.5	32
4	158.5	63.5	158.5	63.5	32
6	222	127	222	127	32
8	286	190.5	286	190.5	32
10	350	190.5	350	190.5	32
12	414	318.5	414	318.5	32
14	478	382.5	510	382.5	32

INLET: 1"

Number of Holes	Ø1 = OUTLET = 1/4" & 3/8"			Ø = INLET = 1"	
	L	L1	L (ABCDE) <small>inlet: 3/8" Type 2 & 4</small>	L1 (ABCDE) <small>inlet: 3/8" Type 2 & 4</small>	L2
2	95	47.5	128	64	32
4	158.5 (159)	63.5	192	64	32
6	222	127	255.2	127	32
8	286	190.5	320	190.5	32
10	350	190.5	382	190.5	32
12	414	318.5	446	318.5	32
14	478	382.5	510	382.5	32

INLET: 1-1/4"

Number of Holes	Ø1 = OUTLET = 3/8" & 1/2"			Ø = INLET = 1-1/4"	
	L	L1	L (ABCDE) <small>inlet: 1/2" Type 2 & 4</small>	L1 (ABCDE) <small>inlet: 1/2" Type 2 & 4</small>	L2
2	152	76	203	101.9	50.8
4	254	101.6	304	101.6	50.8
6	355	203.2	406	203.2	50.8
8	457	304.8	508	304.8	50.8

INLET: 1-1/2"

Number of Holes	Ø1 = OUTLET = 3/8" & 1/2"			Ø = INLET = 1-1/2"	
	L	L1	L2	L2	L2
2	152	76	50.8	50.8	50.8
4	254	101.6	50.8	50.8	50.8
6	355	203.2	50.8	50.8	50.8
8	457	304.8	50.8	50.8	50.8
10	558.6	406.4	50.8	50.8	50.8
12	552	508	50	50	50

Number of Holes	Ø1 = OUTLET = 3/8" & 1/2"			Ø = INLET = 2"	
	L	L1	L2	L2	L2
2	203	101.5	60	60	60
4	305	127	61	61	61
6	432	254	60	60	60
8	559	381	60	60	60



DN9

SERIE 118.09

Materials

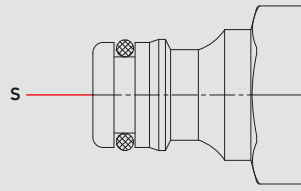
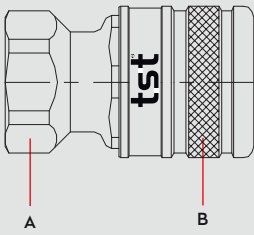

Material Code

A = Brass Chrome Plated

B = Brass Chrome Plated

S = Brass Nickel Plated



0 - 10 bar



-26° to + 200°C (FPM)

Shut Off Type



PLUG COUPLING

OV 300 - 00750-88
(valved)

OM 262 - 01075

FLOW

VALVED 25 lt/min
UNVALVED 35 lt/min

DN

9 mm

Options

Plug Profile Serie 118.09

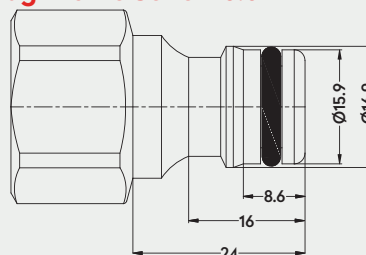

Compatible with

SERIE 118.09



VALVED QUICK COUPLINGS SCHNELLKUPPLUNGEN MIT VENTIL

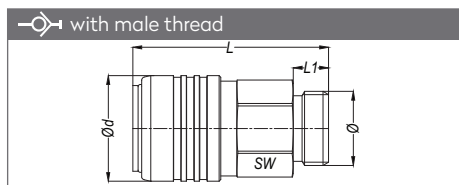

Part No.	Ø	Ød	SW	L	L1
118.09 EG 21	BSP 1/2"	30	25	55.5	10
118.09 EG 26	BSP 3/4"	30	25	57	20

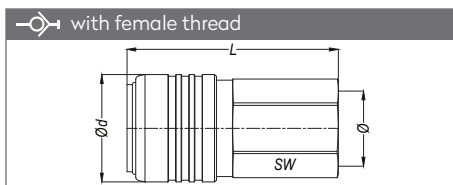

Part No.	Ø	Ød	SW	L
118.09 DG 21	BSP 1/2"	30	25	59

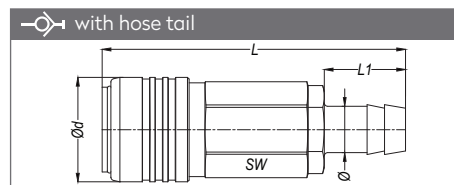

Part No.	Ø	Ød	SW	L	L1
118.09 HG 13	Ø 13 mm - 1/2"	30	25	95	23.3
118.09 HG 16	Ø 16 mm - 5/8"	30	25	106	27.3
118.09 HG 19	Ø 19 mm - 3/4"	30	25	106	27.3

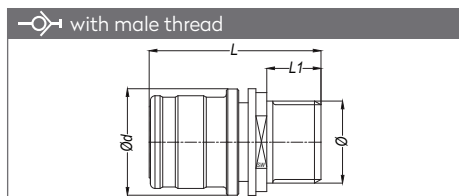

Part No.	Ø	Ød	SW	L	L1
118.09 EG 26-01	BSP 3/4"	34.4	28	55	17.5

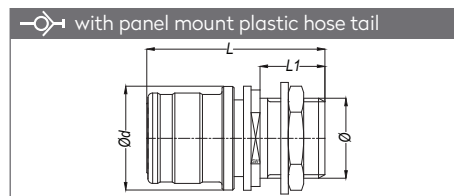

Part No.	Ø	Ød	SW	L	L1
118.09 SG 26 - 00	BSP 3/4"	34.4	28	59	21.5

UNVALVED QUICK COUPLINGS SCHNELLKUPPLUNGEN OHNE VENTIL

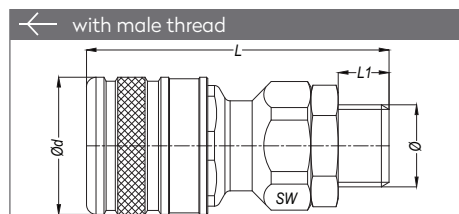

Part No.	Ø	Ød	SW	L	L1
118.09 EGF 21 - PIM	BSP 1/2"	35	30	77	12
118.09 EGF 26 - PIM	BSP 3/4"	35	30	81	16

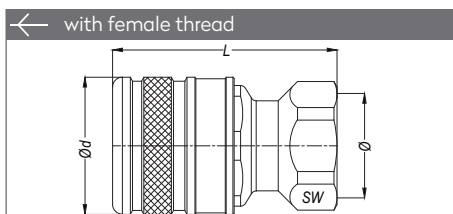

Part No.	Ø	Ød	SW	L
118.09 DGF 26 - PIM	BSP 3/4"	35	30	57

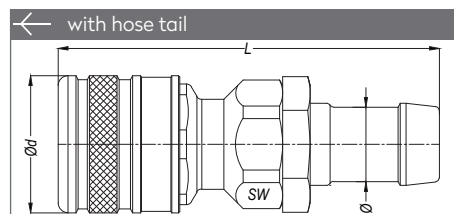

Part No.	Ø	Ød	SW	L	L1
118.09 HGF 13 - PIM	Ø13 mm-1/2"	35	30	99	33
118.09 HGF 16 - PIM	Ø16 mm-5/8"	35	30	99	33
118.09 HGF 19 - PIM	Ø19 mm-3/4"	35	30	99	33

PLUGS STECKNIPPEL

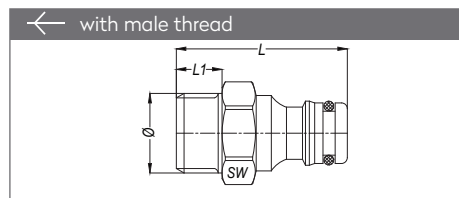

Part No.	Ø	SW	L	L1
118.09 EU 21	BSP 1/2"	24	45	12
118.09 EU 26	BSP 3/4"	30	49	22

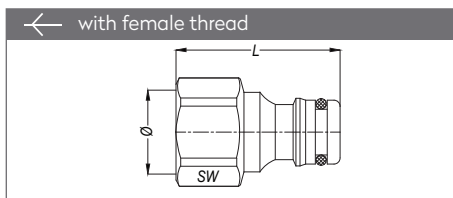

Part No.	Ø	SW	L
118.09 DU 21	BSP 1/2"	24	41
118.09 DU 26	BSP 3/4"	30	39
118.09 DU 33	BSP 1"	41	54.7

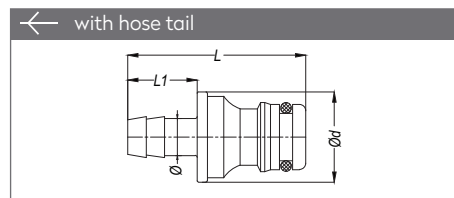

Part No.	Ø	Ød	L	L1
118.09 HU 06	Ø6 mm-1/4"	22	43.5	17
118.09 HU 08	Ø8 mm-5/8"	22	43.5	17
118.09 HU 10	Ø10 mm-3/8"	22	43.5	17
118.09 HU 13	Ø13 mm-1/2"	22	43.5	17
118.09 HU 16	Ø16 mm-5/8"	22	43.8	17.3
118.09 HU 19	Ø19 mm-3/4"	24	43.8	17.3

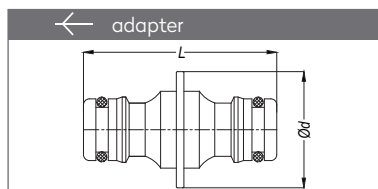

Part No.	L	Ød
118.09 HEF 00	50	30



DN11

WATER COUPLINGS
WASSERKUPPLUNGEN

SERIE 120

Materials

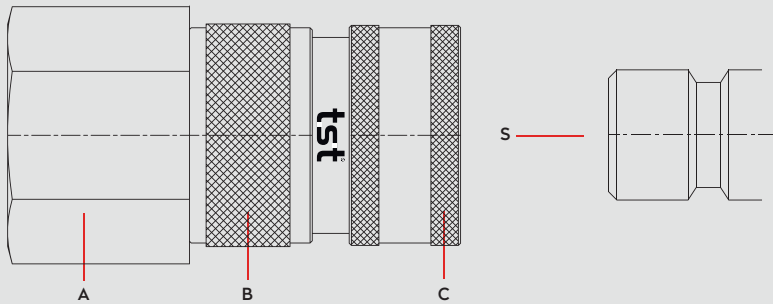

Material Code

- A = Brass
- B = Brass
- C = Brass
- S = Brass



0 - 35 bar



-40° to + 105°C (NBR)

Shut Off Type





120GC00M

FLOW

140 lt/min

DN

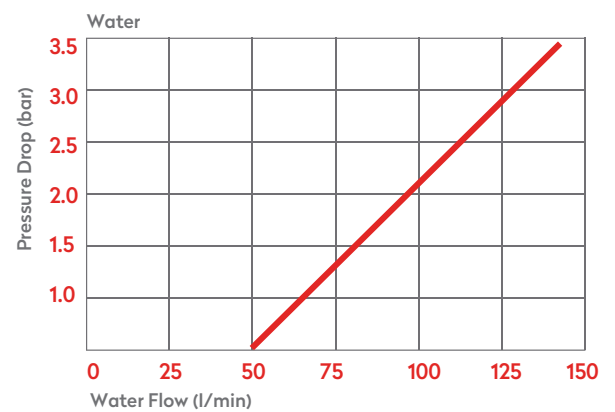
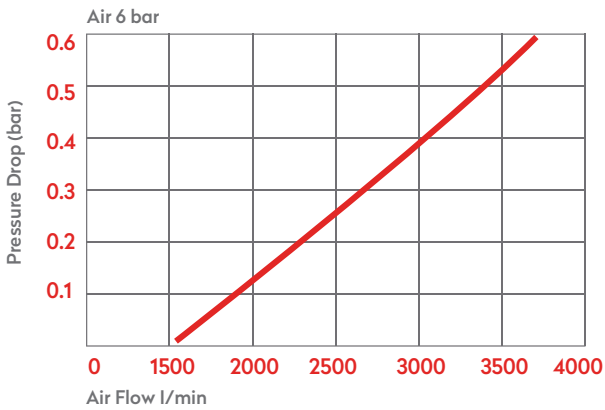
11 mm



Options

NICKEL



Serie 120

Plug Profile Serie 120

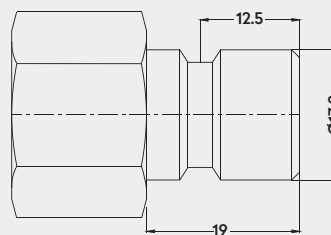

Compatible with

- ABA 3/4"
- PARKER - RECTUS 42



VALVED QUICK COUPLINGS VENTIL SCHNELLKUPPLUNGEN

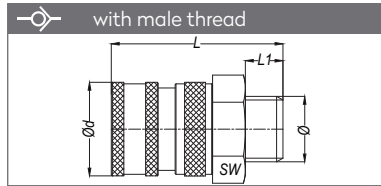

Part No.	Ø	Ød	L	L1	SW
120 EG 21	BSP 1/2"	30	54.5	12	27
120 EG 26	BSP 3/4"	30	54.5	12	30

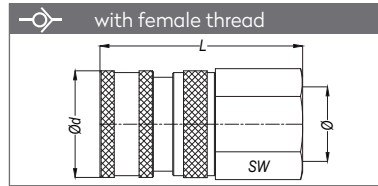

Part No.	Ø	Ød	L	SW
120 DG 21	BSP 1/2"	30	52.5	27
120 DG 26	BSP 3/4"	30	56.5	30

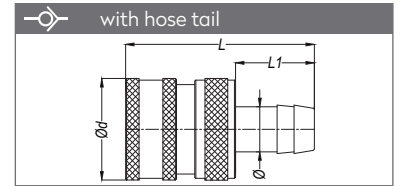

Part No.	Ø	Ød	L	L1
120 HG 13	Ø13	30	70.5	27
120 HG 16	Ø16	30	70.5	27
120 HG 19	Ø19	30	70.5	27

UNVALVED QUICK COUPLINGS SCHNELLKUPPLUNGEN OHNE VENTIL

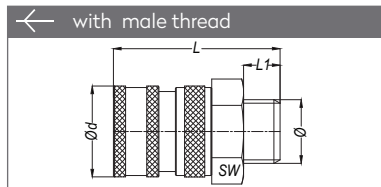

Part No.	Ø	Ød	L	L1	SW
120 EGF 13	BSP 1/4"	30	54.5	10	27
120 EGF 17	BSP 3/8"	30	54.5	10	27
120 EGF 21	BSP 1/2"	30	54.5	12	27
120 EGF 26	BSP 3/4"	30	54.5	12	30

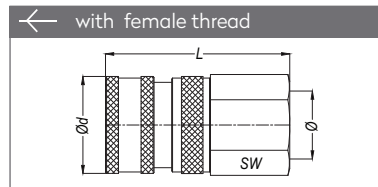

Part No.	Ø	Ød	L	SW
120 DGF 17	BSP 3/8"	30	52.5	27
120 DGF 21	BSP 1/2"	30	52.5	27
120 DGF 26	BSP 3/4"	30	56.5	30

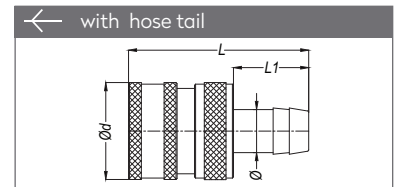

Part No.	Ø	Ød	L	L1
120 HGF 08	8 mm	30	54.3	23.3
120 HGF 09	9 mm	30	54.3	23.3
120 HGF 10	10 mm	30	54.3	23.3
120 HGF 13	13 mm	30	54.3	23.3
120 HGF 16	16 mm	30	54.3	23.3
120 HGF 19	19 mm	30	54.3	23.3

PLUGS STECKNIPPEL

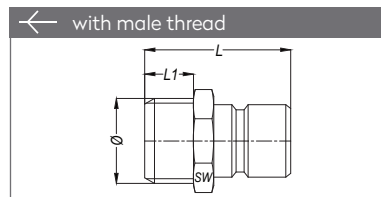

Part No.	Ø	L	L1	SW
120 EU 10	BSP 1/8"	33	9	19
120 EU 13	BSP 1/4"	33	9	19
120 EU 17	BSP 3/8"	33	9	19
120 EU 21	BSP 1/2"	36	12	22
120 EU 26	BSP 3/4"	41	14	27
120 EU 33	BSP 1"	44	16	34

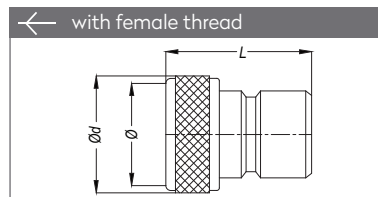

Part No.	Ø	Ød	L
120 DU 13	BSP 1/4"	20	30
120 DU 17	BSP 3/8"	20	30
120 DU 21	BSP 1/2"	24	30
120 DUM 22	M22x1.5	25	30
120 DU 26	BSP 3/4"	30	30

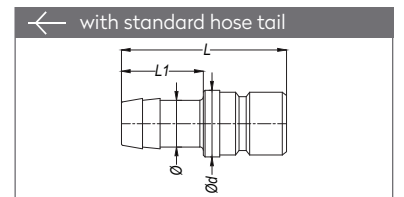

Part No.	Ø	L	L1	ØD
120 HU 09	9 mm	47	23.3	19
120 HU 13	13 mm	47	23.3	19
120 HU 16	16 mm	47	23.3	19
120 HU 19	19 mm	50	27.3	21

ADAPTER ADAPTER

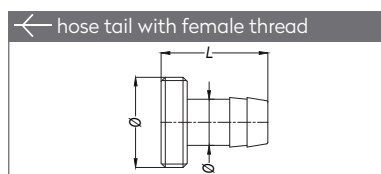

Part No.	Ø	Ø	L	L1
120 GU 08	8 mm	BSP 3/4"	30.8	23.3
120 GU 09	9 mm	BSP 3/4"	30.8	23.3
120 GU 13	13 mm	BSP 3/4"	30.8	23.3
120 GU 16	16 mm	BSP 3/4"	30.8	23.3
120 GU 19	19 mm	BSP 3/4"	30.8	23.3

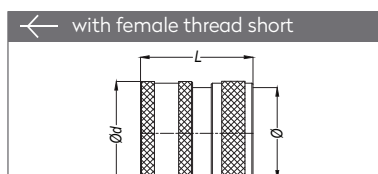

Part No.	Ø	Ød	L
120 BG 26	BSP 3/4"	30	32

DN12 SERIE 121

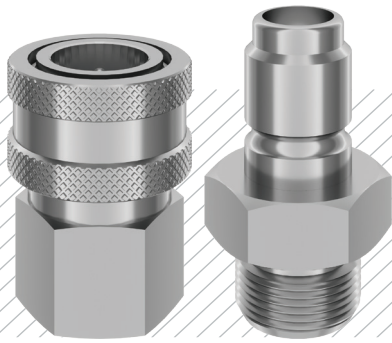

Materials

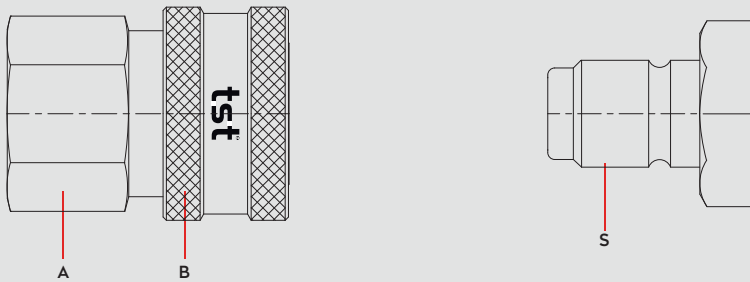

Material Code

A = Stainless Steel AISI316

B = Stainless Steel AISI316

S = Stainless Steel AISI316



Stainless Steel
0 - 100 bar



-26° to + 200°C (FPM)

Shut Off
Type



OV 262 - 01785
OV 262 - 01510

FULL FLOW

DN

12 mm

**PLASTIC
SLEEVE**

121 SP01



Options

EPDM

AISI303
Stainless Steel

Brass
Ms 58

NICKEL

**PLASTIC
SLEEVE**
121 SP01

Plug Profile Serie 121

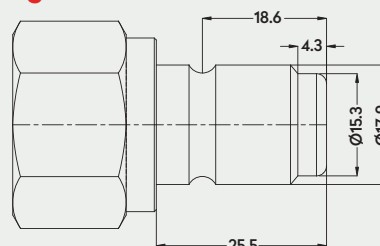

Compatible with

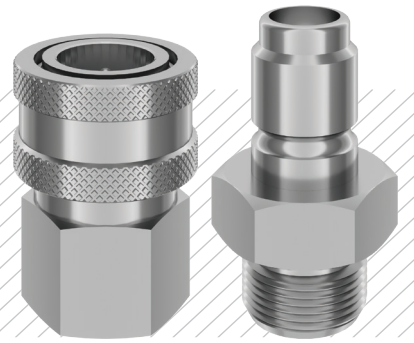

QUICK COUPLINGS SCHNELLKUPPLUNGEN

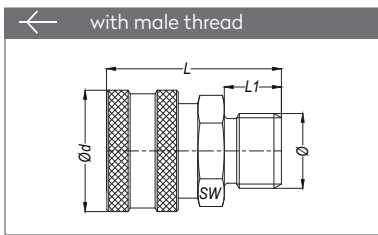

Part No.	Ø	SW	L	L1	Ød
121 EGF 17	BSP 3/8"	27	46	13	34
121 EGF 21	BSP 1/2"	27	49	16	34
121 EGF 26	BSP 3/4"	32	52	19	34

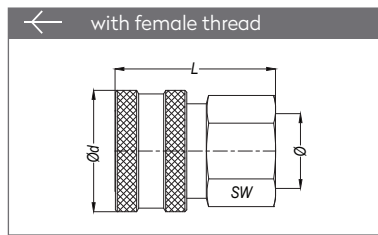

Part No.	Ø	SW	L	Ød
121 DGF 17	BSP 3/8"	27	45	34
121 DGF 21	BSP 1/2"	27	45	34

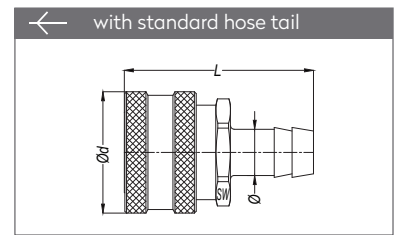

Part No.	Ø	L	Ød
121 HGF 13	Ø 13	53	34
121 HGF 16	Ø 16	62	34
121 HGF 19	Ø 19	62	34
121 HGF 25	Ø 25	62	34

PLUGS STECKNIPPEL

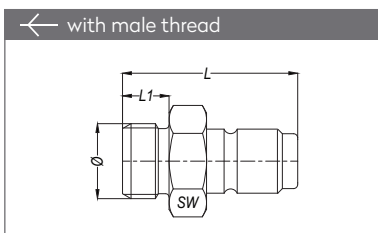

Part No.	Ø	SW	L	L1
121 EU 13	BSP 1/4"	22	45	9
121 EU 17	BSP 3/8"	22	46	10
121 EU 21	BSP 1/2"	27	49	13
121 EU 26	BSP 3/4"	32	53	17

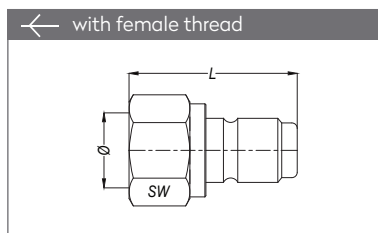

Part No.	Ø	SW	L
121 DU 13	BSP 1/4"	27	42
121 DU 17	BSP 3/8"	27	42
121 DU 21	BSP 1/2"	27	47
121 DU 26	BSP 3/4"	32	50

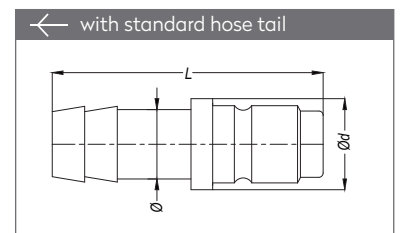

Part No.	Ø	L	Ød
121 HU 13	Ø 13	62,5	21
121 HU 16	Ø 16	62,5	21
121 HU 19	Ø 19	62,5	21



DN 6-16

SERIE 124

HYDRAULIC COUPLINGS
HYDRAULISCHE KUPPLUNGEN

Materials

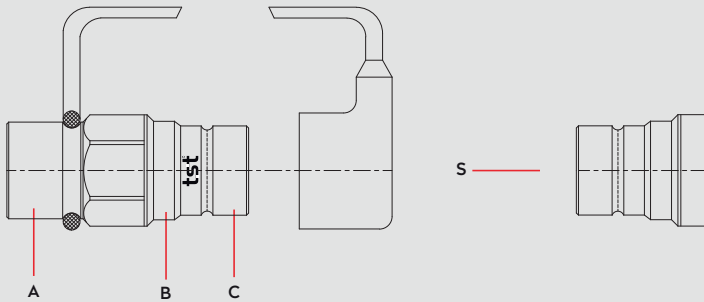

Material Code

A = Steel + Zinc

B = Steel + Zinc

C = AISI420

S = AISI420



TST 124.06 → 0 - 450 bar

TST 124.08 → 0 - 450 bar

TST 124.12 → 0 - 350 bar

TST 124.16 → 0 - 350 bar



-26° to + 200°C (FPM)

Shut Off Type



Residual Pressure

max.

PD (optional)

Serie	124.06	124.08	124.12	124.16
Coupling	-	150	150	150
Plug	40	90	35	60

DN

TST 124.06 → 6 mm

TST 124.08 → 8 mm

TST 124.12 → 12 mm

TST 124.16 → 16 mm

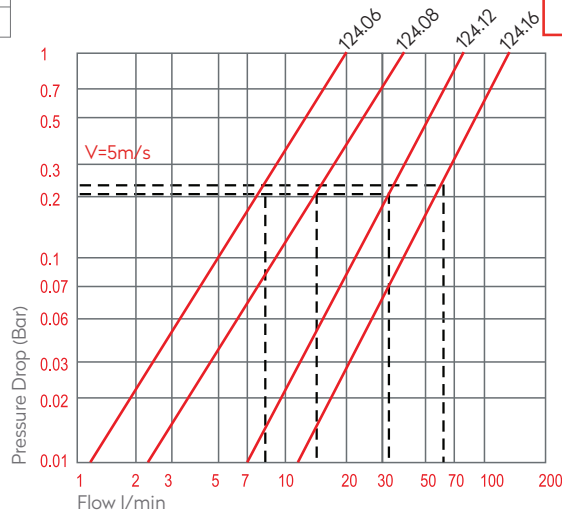

Options

FFKM
124.16

PD

Id.
Ring

Applications

- High pressure
- Hydraulic circuits

Compatible with

HYDRAULIC COUPLINGS
HYDRAULISCHE KUPPLUNGEN

SERIE 124

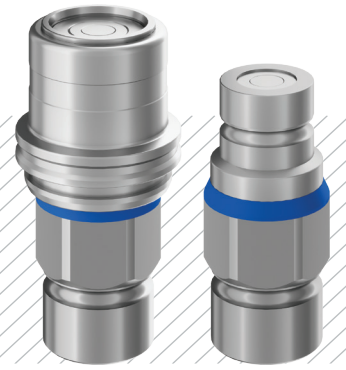

QUICK COUPLINGS SCHNELLKUPPLUNGEN

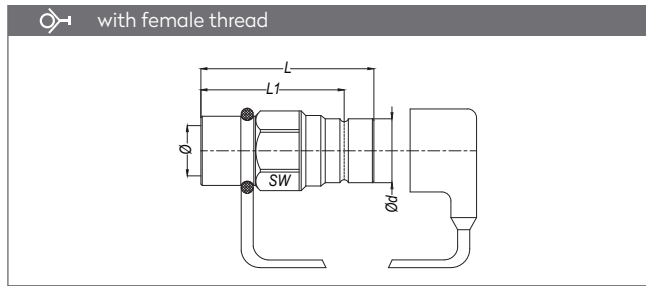

Part no.	DN	Ø	Ød	L	L1	SW
124.06 DGB 17	6	BSP 3/8"	39	76.9	68.9	27
124.06 NGB 17	6	NPT 3/8"	39	77.9	69.9	27
124.08 DGB 21	8	BSP 1/2"	47	90	81.4	32
124.08 NGB 21	8	NPT 1/2"	47	87	78.4	32
124.12 DGB 26	12	BSP 3/4"	59	103.1	93.5	41
124.12 NGB 26	12	NPT 3/4"	59	103.1	93.5	41
124.16 DGB 26	16	BSP 3/4"	69	116.5	106	50
124.16 NGB 26	16	NPT 3/4"	69	116.5	106	50

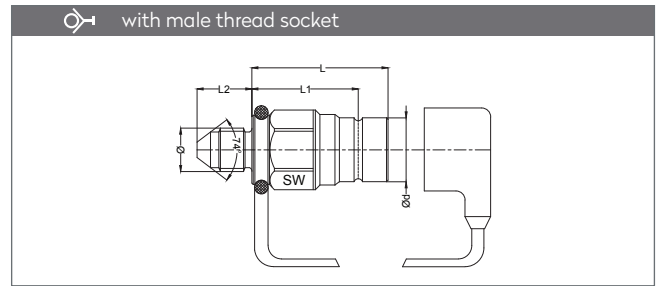

Part no.	DN	Ø	Ød	L	L1	L2	SW
124.06 JGB 13-74	6	UNF 1/2" 20 - Ø5	39	65.4	57.4	14	27
124.08 JGB 19-74	8	UNF 3/4" 16 - Ø8	47	74.5	65.9	17	32
124.12 JGB 22-74	12	UNF 7/8" 14 - Ø10	59	89.6	80	19.5	41
124.16 JGB 27-74	16	UN1- 1/16-12 - Ø12	69	105.1	94.6	22	50

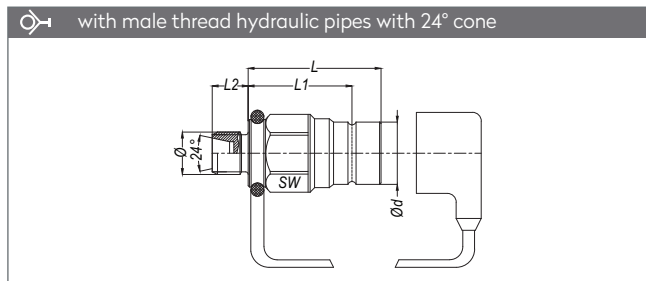

Part no.	DN	Ø	Ød	L	L1	L2	SW
124.06 EGBM 18-10	6	M18x1.5 Ø10 (OD)	39	64.4	56.4	12	27
124.08 EGBM 20-12	8	M20x1.5 Ø12 (OD)	47	75	66.4	12	32
124.12 EGBM 24-16	12	M24x1.5 Ø16 (OD)	59	89.6	80	14	41
124.16 EGBM 30-20	16	M30x2 Ø20 (OD)	69	105.1	94.6	16	50

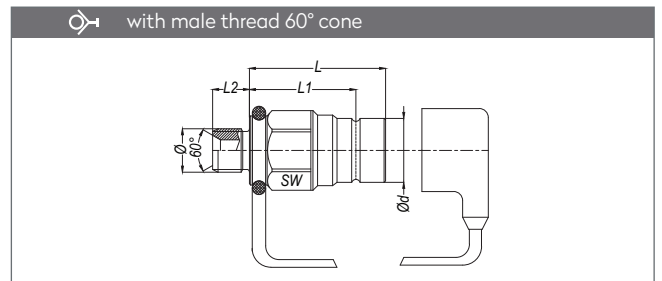

Part no.	DN	Ø	Ød	L	L1	L2	SW
124.06 EGB 17-60	6	BSP 3/8"	39	64.4	56.4	12	27
124.08 EGB 21-60	8	BSP 1/2"	47	75	66.4	14	32
124.12 EGB 26-60	12	BSP 3/4"	59	89.6	80	18.5	41
124.16 EGB 26-60	16	BSP 3/4"	69	105.1	94.6	16	50

HYDRAULIC COUPLINGS
 HYDRAULISCHE KUPPLUNGEN

SERIE 124

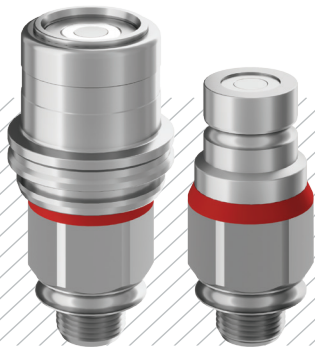

PLUGS STECKNIPPEL

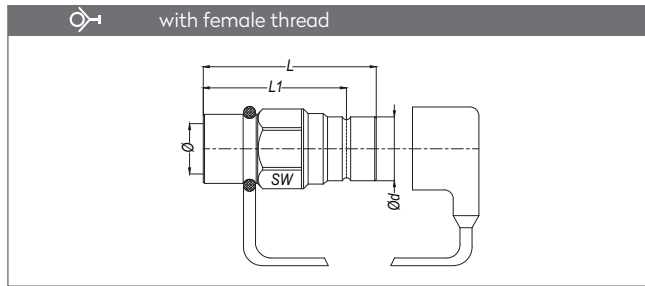

Part no.	DN	Ø	Ød	L	L1	SW
124.06 DUB 17	6	BSP 3/8"	30.5	62.1	51.6	27
124.06 NUB 17	6	NPT 3/8"	30.5	63.1	52.6	27
124.08 DUB 21	8	BSP 1/2"	35.5	73	60.85	32
124.08 NUB 21	8	NPT 1/2"	35.5	70	57.85	32
124.12 DUB 26	12	BSP 3/4"	46	84.3	68.15	41
124.12 NUB 26	12	NPT 3/4"	46	84.3	68.15	41
124.16 DUB 26	16	BSP 3/4"	56.5	94.5	73	50
124.16 NUB 26	16	NPT 3/4"	56.5	94.5	73	50

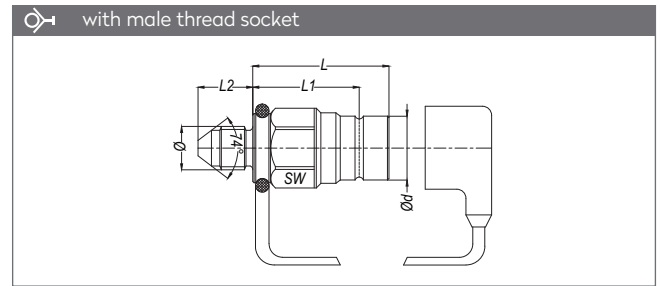

Part no.	DN	Ø	Ød	L	L1	L2	SW
124.06 JUB 13-74	6	UNF 1/2" 20 - Ø5	30.5	50.6	34.6	14	27
124.08 JUB 19-74	8	UNF 3/4" 16 - Ø8	35.5	57.5	45.35	17	32
124.12 JUB 22-74	12	UNF 7/8" 14 - Ø10	46	70.8	54.65	19.5	41
124.16 JUB 27-74	16	UN 1- 1/16-12- Ø12	56.5	83.1	61.6	22	50

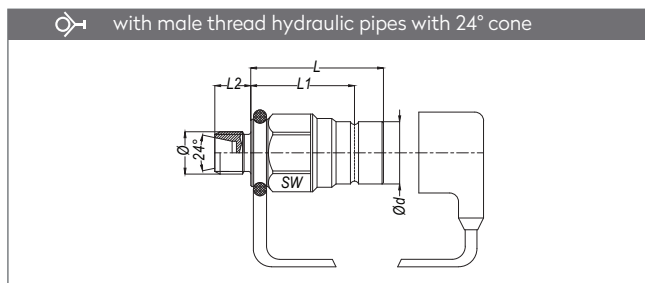

Part no.	DN	Ø	Ød	L	L1	L2	SW
124.06 EUBM 18-10	6	M18x1.5 Ø10 (OD)	30.5	49.6	39.1	12	27
124.08 EUBM 20-12	8	M20x1.5 Ø12 (OD)	35.5	58	45.85	12	32
124.12 EUBM 24-16	12	M24x1.5 Ø16 (OD)	46	70.8	54.65	14	41
124.16 EUBM 30-20	16	M30x2 Ø20 (OD)	56.5	83.1	61.6	16	50

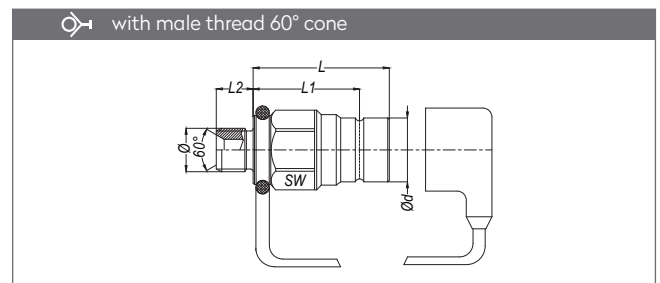

Part no.	DN	Ø	Ød	L	L1	L2	SW
124.06 EUB 17-60	6	BSP 3/8"	30.5	49.6	39.1	12	27
124.08 EUB 21-60	8	BSP 1/2"	35.5	58	45.85	14	32
124.12 EUB 26-60	12	BSP 3/4"	46	70.8	54.65	18.5	41
124.16 EUB 26-60	16	BSP 3/4"	56.5	83.1	61.6	16	50

HYDRAULIC COUPLINGS
HYDRAULISCHE KUPPLUNGEN

SERIE 124

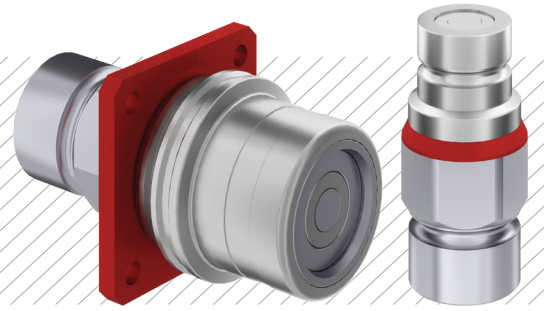

QUICK COUPLINGS SCHNELLKUPPLUNGEN

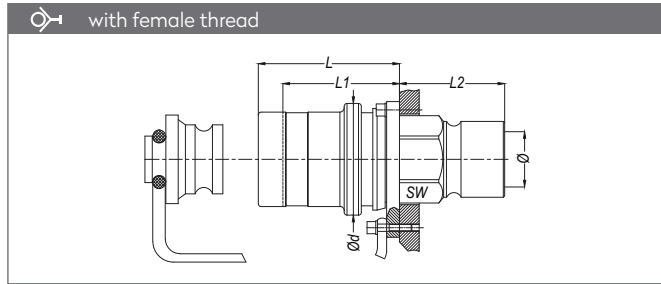

Part no.	DN	Ø	Ød	L	L1	L2	SW
1241.06 DGB 17	6	BSP 3/8"	39	44	36	32.9	27
1241.06 NGB 17	6	NPT 3/8"	39	44	36	32.9	27
1241.08 DGB 21	8	BSP 1/2"	47	50.1	41.5	39.9	32
1241.08 NGB 21	8	NPT 1/2"	47	50.1	41.5	36.9	32
1241.12 DGB 26	12	BSP 3/4"	59	61.2	51.6	44.9	41
1241.12 NGB 26	12	NPT 3/4"	59	61.2	51.6	44.9	41
1241.16 DGB 26	16	BSP 3/4"	69	71.1	60.6	45.4	50
1241.16 NGB 26	16	NPT 3/4"	69	71.1	60.6	45.4	50

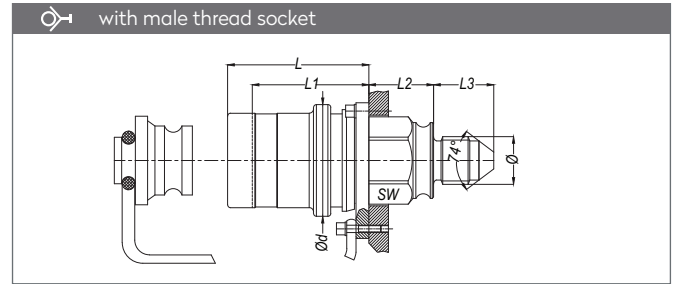

Part no.	DN	Ø	Ød	L	L1	L2	L3	SW
1241.06 JGB 13-74	6	UNF 1/2" 20 - Ø5	39	44	36	13.4	14	27
1241.08 JGB 19-74	8	UNF 3/4" 16 - Ø8	47	50.1	41.5	24.9	16.5	32
1241.12 JGB 22-74	12	UNF 7/8" 14 - Ø10	59	61.2	51.6	9.1	19.3	41
1241.16 JGB 27-74	16	UNF 1 1/16-12" 12 - Ø12	69	71.1	60.6	33.9	22	50

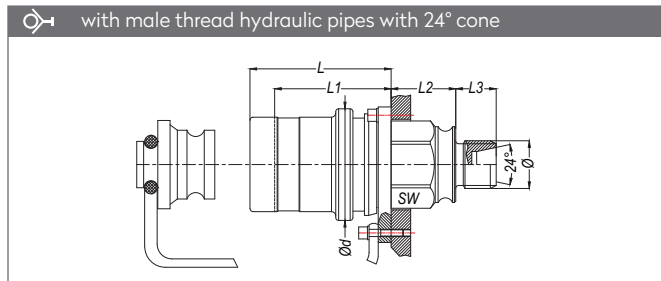

Part no.	DN	Ø	Ød	L	L1	L2	L3	SW
1241.06 EGBM 18-10	6	M18x1.5 Ø10 (OD)	39	44	36	12.4	12	27
1241.08 EGBM 20-12	8	M20x1.5 Ø12 (OD)	47	50.1	41.5	24.9	12	32
1241.12 EGBM 24-16	12	M24x1.5 Ø16 (OD)	59	61.2	51.6	14.4	14	41
1241.16 EGBM 30-20	16	M30x2 Ø20 (OD)	69	71.1	60.6	33.9	16	50

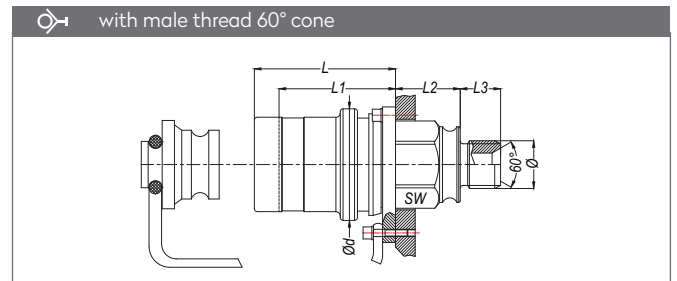

Part no.	DN	Ø	Ød	L	L1	L2	L3	SW
1241.06 EGB 17-60	6	BSP 3/8"	39	44	36	12.4	12	27
1241.08 EGB 21-60	8	BSP 1/2"	47	50.1	41.5	24.9	14	32
1241.12 EGB 26-60	12	BSP 3/4"	59	61.2	51.6	9.9	18.5	41
1241.16 EGB 26-60	16	BSP 3/4"	69	71.1	60.6	33.9	16	50

HYDRAULIC COUPLINGS
 HYDRAULISCHE KUPPLUNGEN

SERIE 124

PLUGS STECKNIPPEL

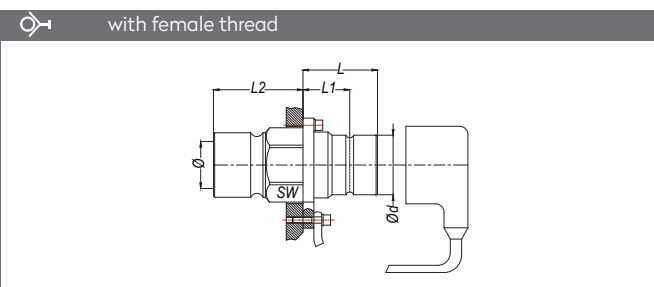

Part no.	DN	Ø	Ød	L	L1	L2	SW
1241.06 DUB 17	6	BSP 3/8"	29.5	29.2	14.2	33	27
1241.06 NUB 17	6	NPT 3/8"	29.5	29.2	14.2	34	27
1241.08 DUB 21	8	BSP 1/2"	35.5	33.1	20.7	39.9	32
1241.08 NUB 21	8	NPT 1/2"	35.5	33.1	20.7	36.9	32
1241.12 DUB 26	12	BSP 3/4"	46	42.4	26.3	44.9	41
1241.12 NUB 26	12	NPT 3/4"	46	42.4	26.3	44.9	41
1241.16 DUB 26	16	BSP 3/4"	56.5	46.1	27.6	48.4	50
1241.16 NUB 26	16	NPT 3/4"	56.5	46.1	27.6	48.4	50

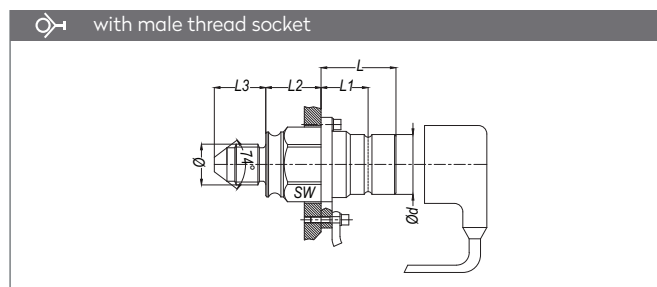

Part no.	DN	Ø	Ød	L	L1	L2	L3	SW
1241.06 JUB 13-74	6	UNF 1/2" 20 - Ø5	29.5	29.2	18.7	21.4	14	27
1241.08 JUB 19-74	8	UNF 3/4" 16 - Ø8	35.5	33.1	20.95	24.4	17	32
1241.12 JUB 22-74	12	UNF 7/8" 14 - Ø10	46	42.4	26.25	28.4	19.5	41
1241.16 JUB 27-74	16	UN 1 1/16-12 - Ø12	56.5	49.1	27.6	34	22	50

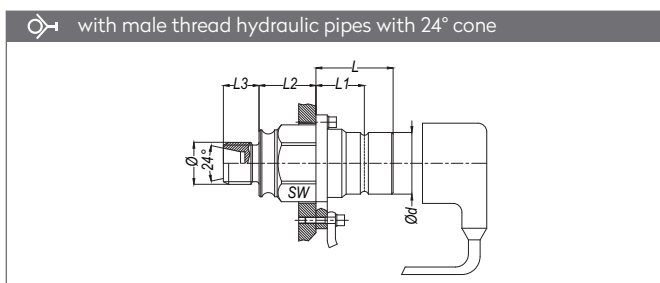

Part no.	DN	Ø	Ød	L	L1	L2	L3	SW
1241.06 EUBM 18-10	6	M18x1.5 Ø10 (OD)	29.5	29.2	18.7	20.4	12	27
1241.08 EUBM 20-12	8	M20x1.5 Ø12 (OD)	35.5	33.1	20.95	24.9	12	32
1241.12 EUBM 24-16	12	M24x1.5 Ø16 (OD)	46	42.4	26.25	28.4	14	41
1241.16 EUBM 30-20	16	M30x2 Ø20 (OD)	56.5	49.1	27.6	34	16	50

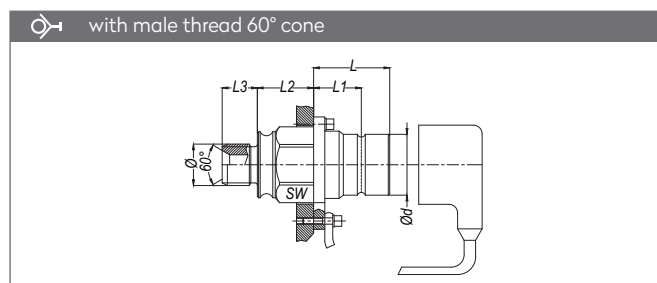

Part no.	DN	Ø	Ød	L	L1	L2	L3	SW
1241.06 EUB 17-60	6	BSP 3/8"	29.5	29.2	18.7	20.4	12	27
1241.08 EUB 21-60	8	BSP 1/2"	35.5	33.1	20.95	24.9	14	32
1241.12 EUB 26-60	12	BSP 3/4"	46	42.4	26.25	28.4	18.5	41
1241.16 EUB 26-60	16	BSP 3/4"	56.5	49.1	27.6	34	16	50

SERIE 124



QUICK COUPLINGS SCHNELLKUPPLUNGEN

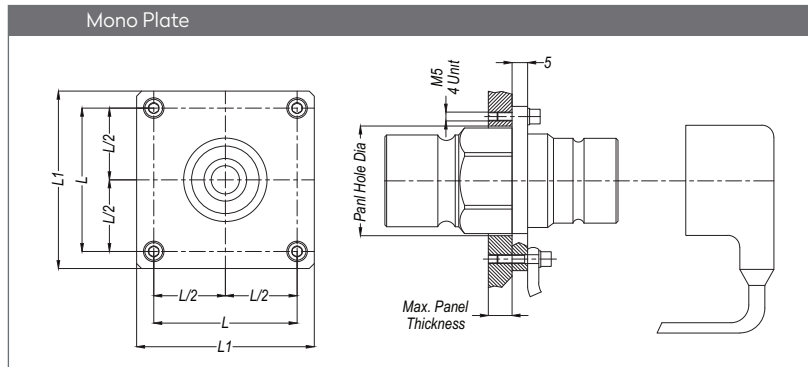
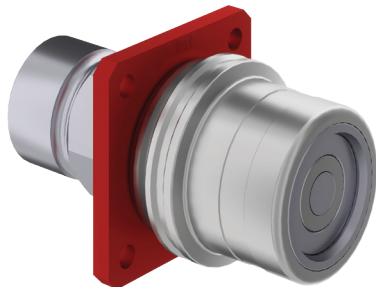
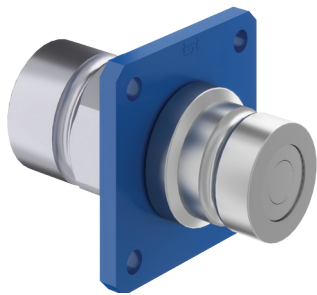

Serie	Max. Panel Thickness	Panel Hole	L	L1	A
124.06	8	32	39	50	5
124.08	10	37.5	40	53	5
124.12	10	48	52	65	8
124.16	10	58	57	70	8

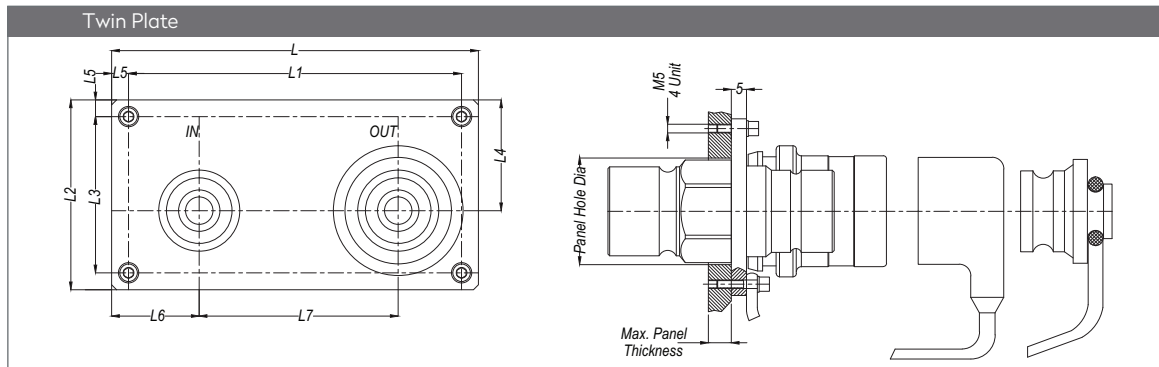

Serie	Max. Panel Thickness	Panel Hole	L	L1	L2	L3	L4	L5	L6	L7	A
124.06	8	32	84	95	53	42	29.5	5.5	23.5	48	5
124.08	10	37.5	97	110	63	50	36.5	6.5	26	58	5
124.12	10	48	122	135	75	62	42.5	6.5	32.5	70	8
124.16	10	58	137	150	80	67	45	6.5	35	80	8



DN 8-33

HYDRAULIC COUPLINGS
HYDRAULISCHE KUPPLUNGEN

SERIE 126

Materials

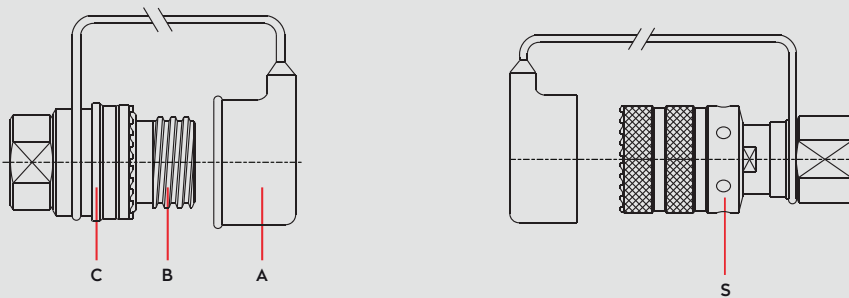

Material Code

- A = Neoprene*
*Serie 126.08 - 126.12
- A = Aluminium*
*Serie 126.20 - 126.25 - 126.33
- B = AISI 303
- C = AISI 420 - Black Chrome
- S = AISI 420 - Black Chrome
- S = AISI 8620 - Black Chrome*
*Serie 126.25 - 126.33

DN 8 - 25 → 0 - 500 bar
DN 33 → 0 - 350 bar

-26° to + 200°C (FPM)

Shut Off Type

Screw Type

FF

DN

- TST 126.08 → 8 mm
- TST 126.12 → 12 mm
- TST 126.20 → 20 mm
- TST 126.25 → 25 mm
- TST 126.33 → 33 mm

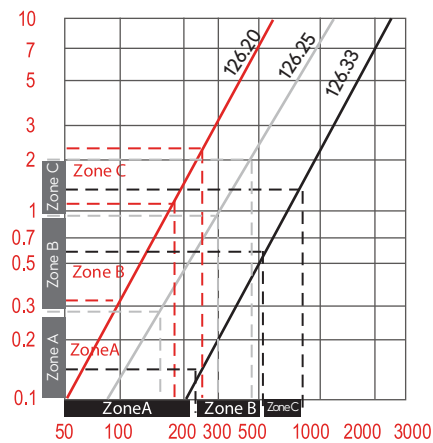
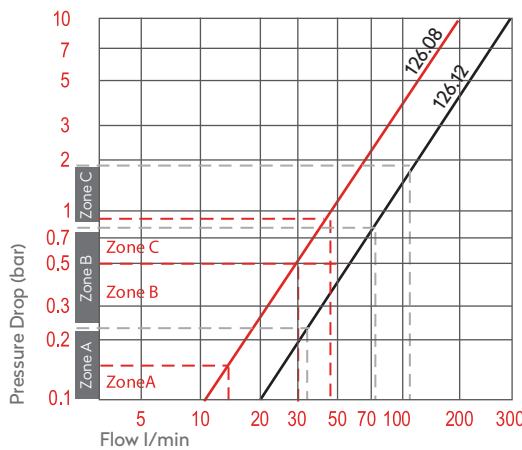

Options

DN 20-25-33

EPDM

Applications

- Steel Industry
- Road Breaker
- Die Casting

Compatible with

HYDRAULIC COUPLINGS
HYDRAULISCHE KUPPLUNGEN

SERIE 126



QUICK COUPLINGS SCHNELLKUPPLUNGEN

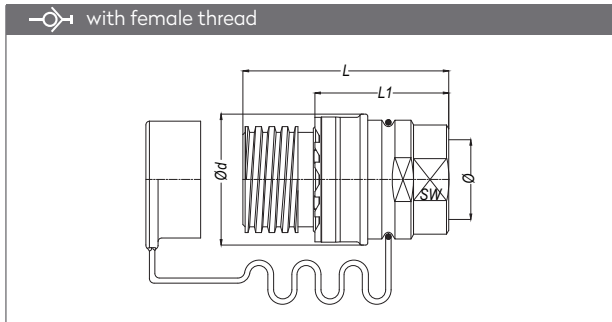

Part No.	Ø	Ød	L	L1	SW
126.08 DGB 21	BSP 1/2"	50	75.5	50	32
126.08 NGB 21	NPT 1/2"	50	75.5	50	32
126.08 UGB 19	UNF 3/4"-16	50	75.5	50	32
126.12 DGB 26	BSP 3/4"	59.6	93.5	61.5	46
126.12 NGB 26	NPT 3/4"	59.6	93.5	61.5	46
126.12 UGB 27	UNF 1 1/16"-12	59.6	93.5	61.5	46
126.20 DGB 33	BSP 1"	73	110	75.5	50
126.20 NGB 33	NPT 1"	73	110	75.5	50
126.20 UGB 33	UN 1 5/16"-12	73	110	75.5	50
126.25 DGB 42	BSP 1 1/4"	91	140.6	95.1	65
126.25 NGB 42	NPT 1 1/4"	91	145.6	100.1	65
126.25 UGB 41	UN 1 5/8"-12	91	140.6	95.1	65
126.33 DGB 48	BSP 1 1/2"	107	152.5	99.5	80

PLUGS STECKNIPPEL

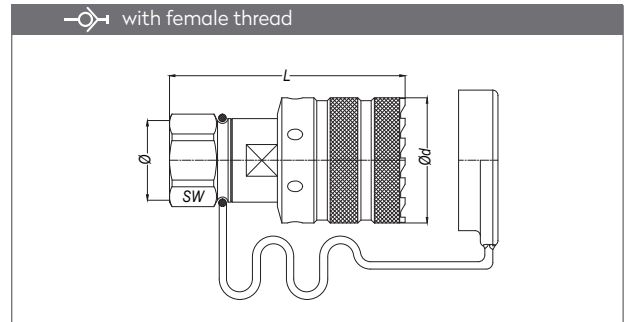

Part No.	Ø	Ød	L	SW
126.08 DUB 21	BSP 1/2"	47	94.7	30
126.08 NUB 21	NPT 1/2"	47	94.7	30
126.08 UUB 19	UN 3/4"-16	47	94.7	30
126.12 DUB 26	BSP 3/4"	57	107.1	38
126.12 NUB 26	NPT 3/4"	57	107.1	38
126.12 UUB 27	UN 1 1/16"-12	57	107.1	38
126.20 DUB 33	BSP 1"	70	123.5	46
126.20 NUB 33	NPT 1"	70	123.5	46
126.20 UUB 33	UN 1 5/16"-12	70	123.5	46
126.25 DUB 42	BSP 1 1/4"	88	139.7	58
126.25 NUB 42	NPT 1 1/4"	88	142.2	58
126.25 UUB 41	UN 1 5/8"-12	88	139.7	58
126.33 DUB 48	BSP 1 1/2"	108	157	70

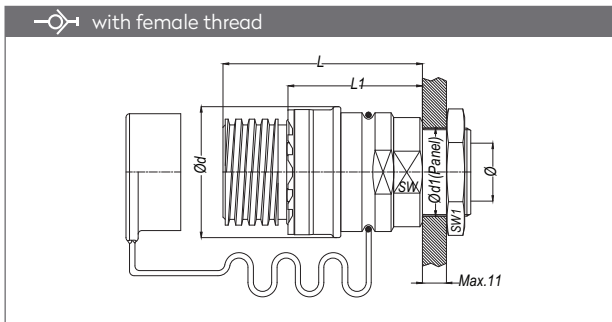

Part No.	Ø	Ød	Ød1 (panel)	L	L1	SW1 (Locknut)	SW
1261.12 DGB 26	BSP 3/4"	59.6	41	90.5	57.9	50	46
1261.12 NGB 26	NPT 3/4"	59.6	41	90.5	57.9	50	46
1261.12 UGB 27	UN 1 1/16"-12	59.6	41	90.5	57.9	50	46
1261.20 DGB 33	BSP 1"	73	51	102	65.6	75	50
1261.20 NGB 33	NPT 1"	73	51	102	65.6	75	50

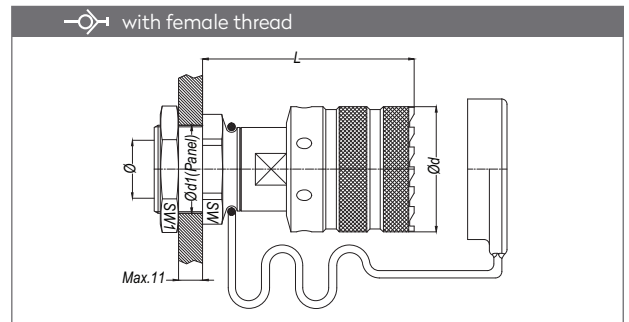

Part No.	Ø	Ød	Ød1	L	SW1 (Locknut)	SW
1261.12 DUB 26	BSP 3/4"	57	41	96.1	50	46
1261.12 NUB 26	NPT 3/4"	57	41	96.1	50	46
1261.12 UUB 27	UN 1 1/16"-12	57	41	96.1	50	46
1261.20 DUB 33	BSP 1"	70	51	106.5	75	50
1261.20 NUB 33	NPT 1"	70	51	106.5	75	50

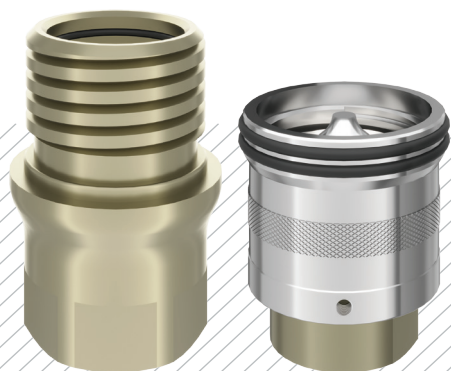

DN 37

MOULD COOLING COUPLINGS

KÜHLUNGSELEMENTE FÜR WERKZEUGE

SERIE 127

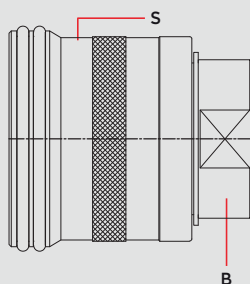
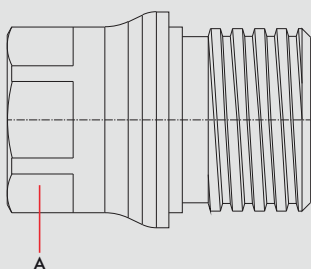
Materials

Material Code

A = Brass / Chemical Nickel Plated

B = Brass

C = AISI 303

S = AISI 303



0 - 10 bar



-40°C to +105°C (NBR)

Shut Off Type

COUPLING

 OM 353 - 06350 - 90
 OM 353 - 03455 - 90
 TC - 7020 - 6400 - 13

PLUG

 OM 534 - 08510
 OM 353 - 03455 - 90

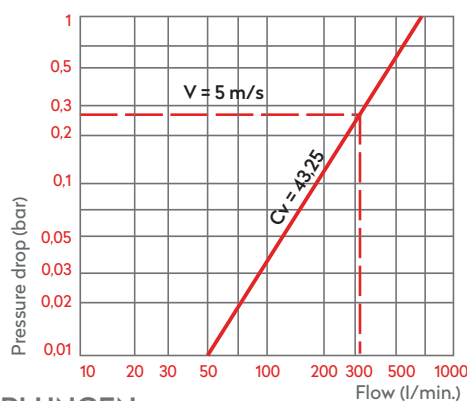
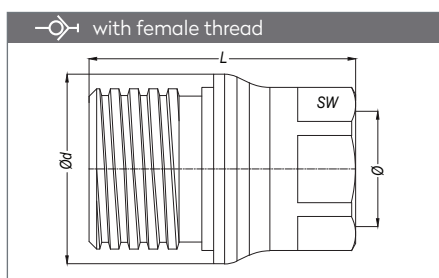
Screw Type

DN
37 mm
QUICK COUPLINGS SCHNELLKUPPLUNGEN

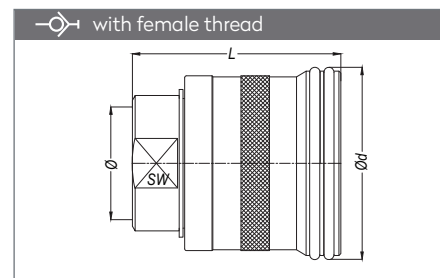
Part No.	Ø	Ød	L	SW
127.37 DGB 60	BSP 2"	98	138	77
127.37 NGB 60	NPT 2"	98	138	77
127.37 UGB 63	UN 2 1/2"-12	98	138	77

PLUGS STECKNIPPEL

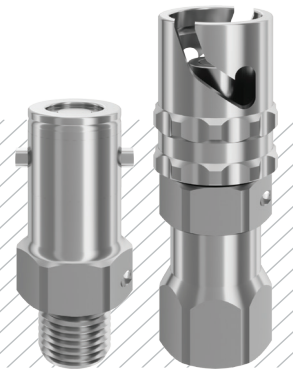
Part No.	Ø	Ød	L	SW
127.37 DUB 60	BSP 2"	98	111	67
127.37 NUB 60	NPT 2"	98	111	67
127.37 UUB 63	UN 2 1/2"-12	98	111	67



Materials

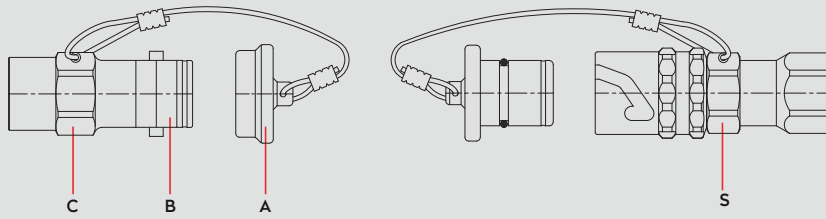

Material Code

- A = Black Delrin
- *Serie 128.03 → Aluminium
- B = AISI 316
- C = AISI 316
- S = AISI 316

DN	TST 128.03 → 3 mm
	TST 128.05 → 5 mm
	TST 128.08 → 8 mm
	TST 128.12 → 12 mm

-40° to +105°C (NBR)

Shut Off Type

DN	3	5	8	12
	350 bar	160 bar	80 bar	50 bar

FF

E2

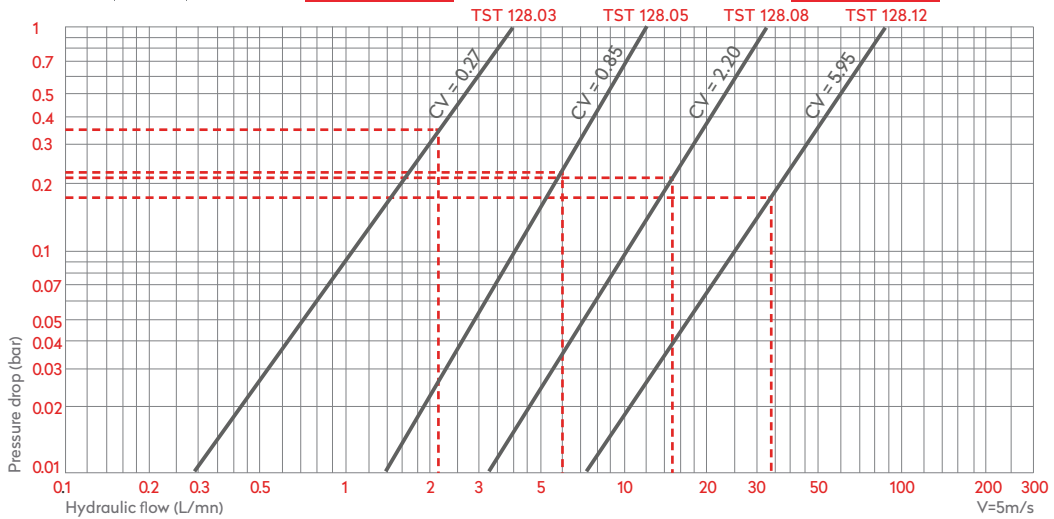

Options

- FPM
-
- FFKM 128.08

Applications

- Mold Cooling
- Chemical Industry

Compatible with

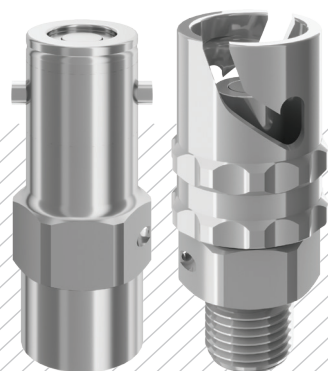

 MULTI PURPOSE COUPLINGS
 MEHRFACHE ANWENDUNGEN

SERIE 128

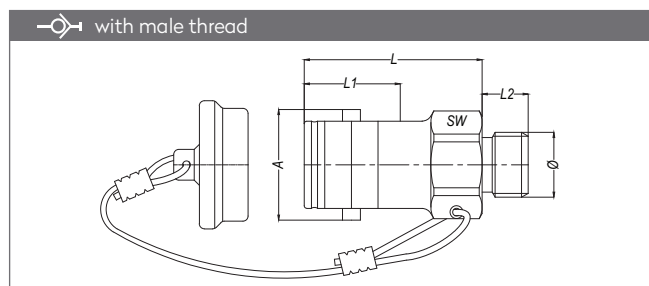
QUICK COUPLINGS SCHNELLKUPPLUNGEN

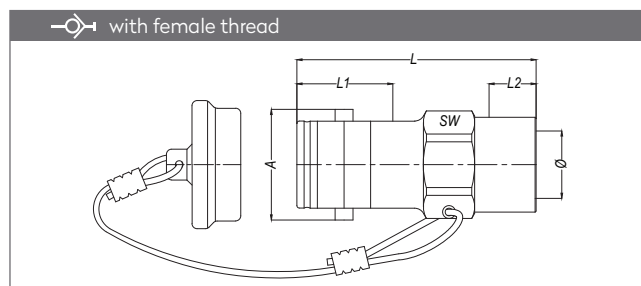

Part No.	DN	Ø	A	L	L1	L2	SW
128.03 EGB 10	3	BSP 1/8"	16.6	38.6	18	7.9	14
128.05 EGB 13	5	BSP 1/4"	21.2	33.5	19	11	19
128.08 EGB 17	8	BSP 3/8"	28	37.9	23.5	12	27
128.12 EGB 21	12	BSP 1/2"	27.9	53.9	36.2	14	36



Part No.	DN	Ø	A	L	L1	L2	SW
128.03 DGB 10	3	BSP 1/8"	16.6	46.5	18	10.5	14
128.05 DGB 13	5	BSP 1/4"	21.2	46.7	18.7	13	19
128.08 DGB 17	8	BSP 3/8"	27.9	49.9	23.2	13	27
128.12 DGB 21	12	BSP 1/2"	39.6	69.4	36.2	16.5	36

PLUGS STECKNIPPEL

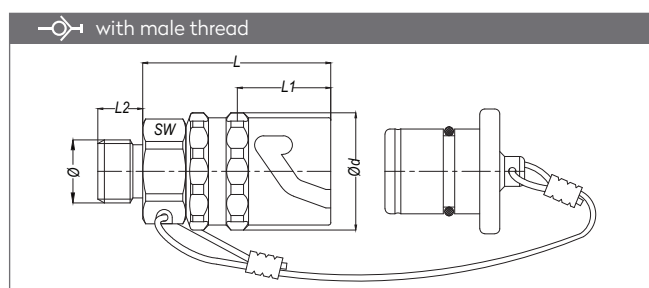

Part No.	DN	Ø	Ød	L	L1	L2	SW
128.03 EUB 10	3	BSP 1/8"	18.9	35.8	18	7.9	14
128.05 EUB 13	5	BSP 1/4"	23.5	37.5	18.7	11	19
128.08 EUB 17	8	BSP 3/8"	30.5	56.4	23.2	12	22
128.12 EUB 21	12	BSP 1/2"	41.5	72.6	36.2	14	27

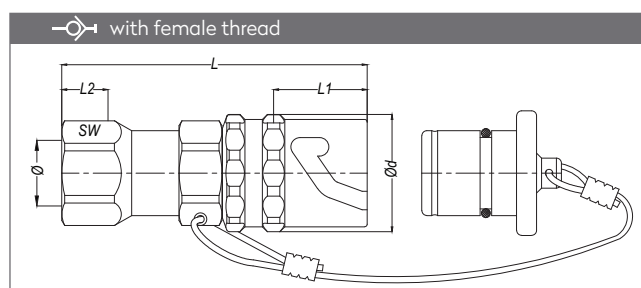

Part No.	DN	Ø	Ød	L	L1	L2	SW
128.03 DUB 10	3	BSP 1/8"	18.9	48.8	18	9.5	14
128.05 DUB 13	5	BSP 1/4"	23.5	61.2	18.7	12	19
128.08 DUB 17	8	BSP 3/8"	30.5	68.6	23.2	13	22
128.12 DUB 21	12	BSP 1/2"	41.5	91.6	36.2	16	27



DN10-25

SERIE 152mono

HYDRAULIC COUPLINGS

HYDRAULISCHE KUPPLUNGEN

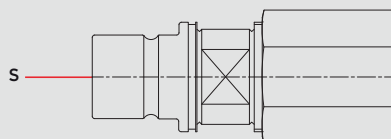
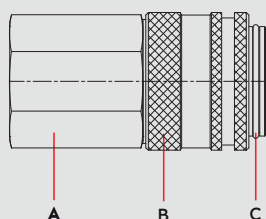
Materials

Material Code

A = Brass

B = Brass

C = Brass

S = AISI 303*

TST 152.20 → Brass

TST 152.25 → Brass



0 - 50 bar



-26°C to + 200°C (FPM)

Shut Off Type

Applications

- Temperature controlling

FF
Compatible with

TST DESIGN

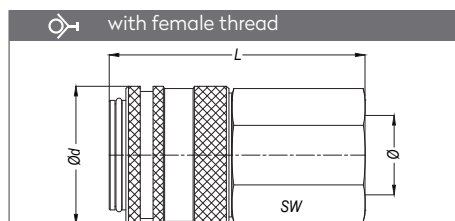
DN 10-25 mm
QUICK COUPLINGS SCHNELLKUPPLUNGEN

Part no.	Ø	SW	Ød	L
152.10 DGB 17	BSP 3/8"	25	28.9	53.7
152.12 DGB 21	BSP 1/2"	30	34	57.5
152.16 DGB 26	BSP 3/4"	36	44.5	72.4
152.20 DGB 33	BSP 1"	46	59	91.5
152.25 DGB 42	BSP 1 1/4"	40	67	140.8

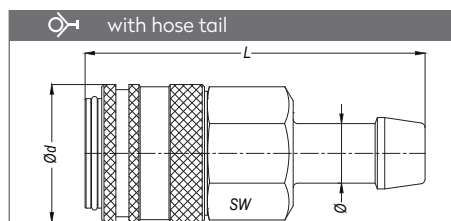

Part no.	Ø	SW	Ød	L
152.10 HGB 13	13	25	28.9	69.7
152.12 HGB 16	16	30	34	73.5
152.16 HGB 19	19	-	44.5	85.9

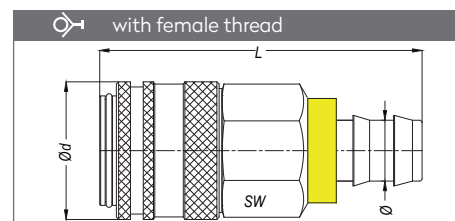

Part no.	Ø	SW	Ød	L
152.10 FGB 13	13	25	28.9	70
152.12 FGB 16	16	30	34	73.5
152.16 FGB 19	19	-	44.5	90.9

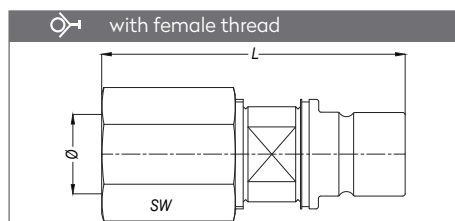
PLUGS STECKNIPPEL

Part no.	Ø	SW	L
152.10 DUB 17	BSP 3/8"	25	63.7
152.12 DUB 21	BSP 1/2"	30	66.7
152.16 DUB 26	BSP 3/4"	36	82.8
152.20 DUB 33	BSP 1"	46	99.5
152.25 DUB 42	BSP 1 1/4"	50	148.5

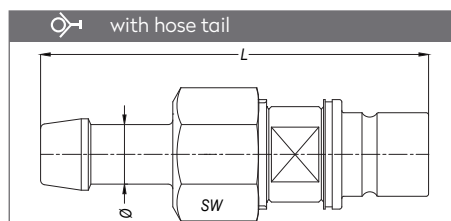

Part no.	Ø	SW	L
152.10 HUB 13	13	25	79.7
152.12 HUB 16	16	30	80.3
152.16 HUB 19	19	-	96.3

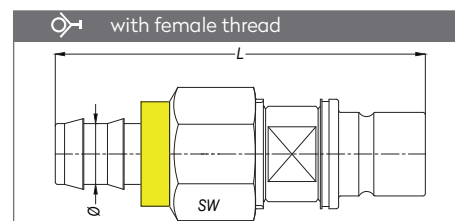

Part no.	Ø	SW	L
152.10 FUB 13	13	25	80
152.12 FUB 16	16	30	90
152.16 FUB 19	19	-	101.3

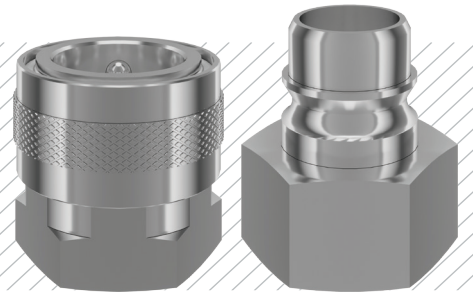

Materials

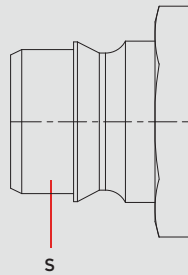
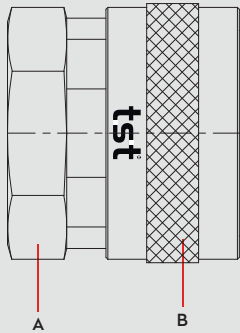

Material Code

A = Brass Chrome Plated

B = Brass Chrome Plated

S = Brass Chrome Plated



0 - 25 bar



-40° to + 105°C (NBR)

Shut Off Type



OM 300 - 02000
CON - 2450 - 1800 - 20

FULL FLOW

DN

16 mm

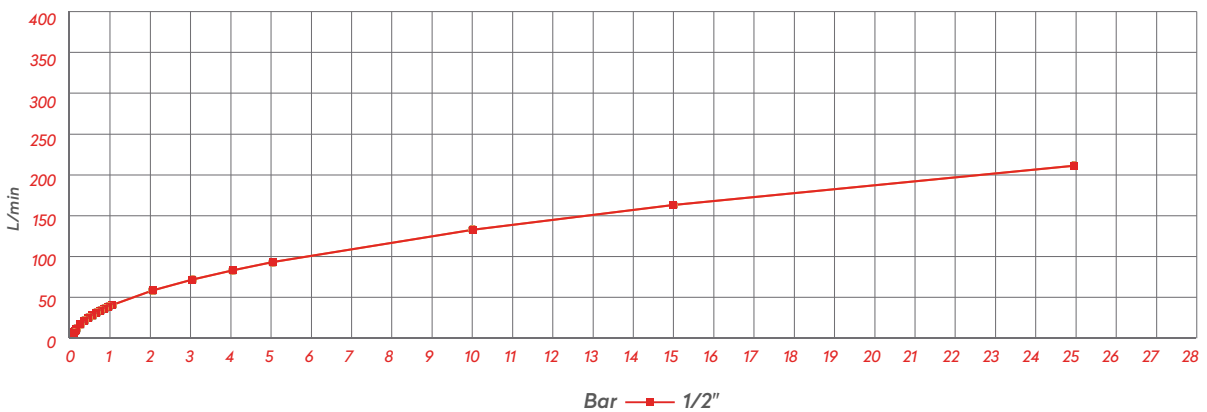

Options



AISI303
Stainless Steel

AISI316
Stainless Steel

FPM

Plug Profile Serie 160

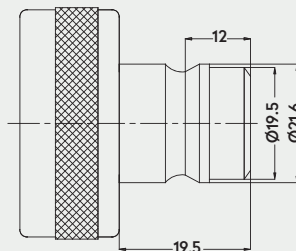

Compatible with

DYROS 2000
NITO 3/4" (5360)

WATER COUPLINGS
WASSERKUPPLUNGEN

SERIE 160

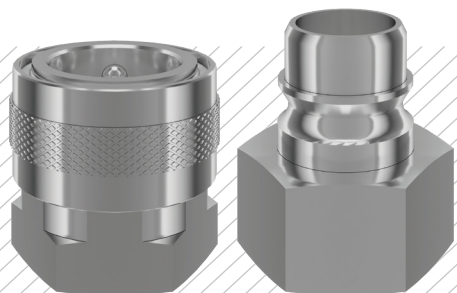

UNVALVED QUICK COUPLINGS SCHNELLKUPPLUNGEN OHNE VENTIL

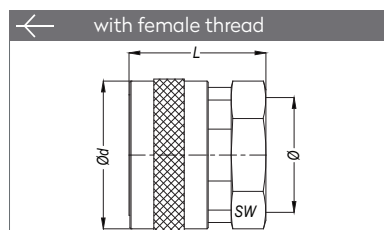

Part No.	Ø	Ød	L	SW
160 DGF 26	BSP 3/4"	35	31.5	30

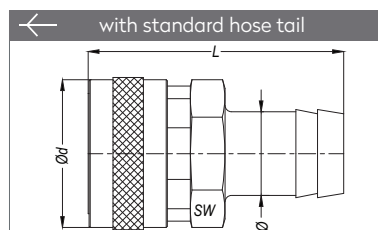

Part No.	Ø	Ød	L
160 HGF 19	Ø 19	35	57.8

PLUGS STECKNIPPEL

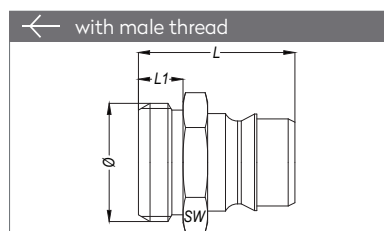

Part No.	Ø	L	L1	SW
160 EU 26	BSP 3/4"	35	10	27

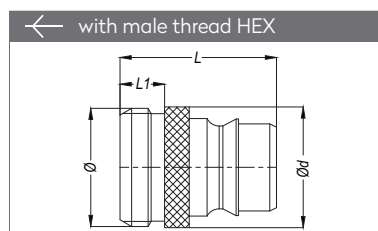

Part No.	Ø	Ød	L	L1
160 EU 26 - 01	BSP 3/4"	27	35	10

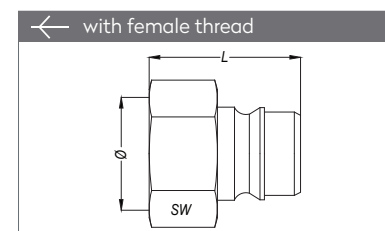

Part No.	Ø	SW	L
160 DU 26	BSP 3/4"	30	35.5

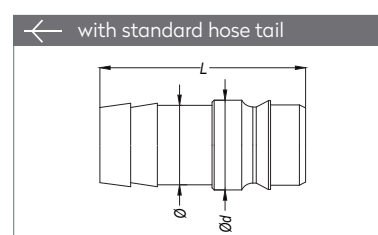

Part No.	Ø	Ød	L
160 HU 13	Ø 13	21.8	47
160 HU 19	Ø 19	21.8	50

ADAPTER ADAPTER

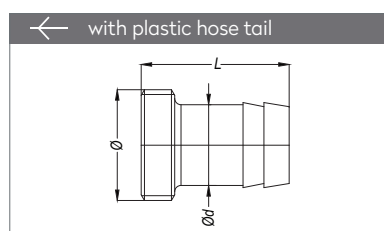

Part No.	Ø - Ød	L
160 GU 19	BSP 3/4" - Ø19	35.3

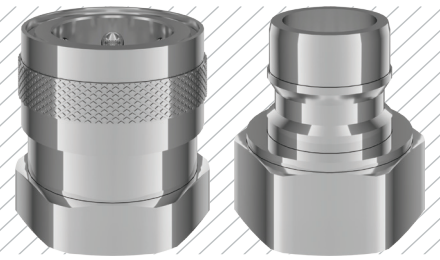

Materials

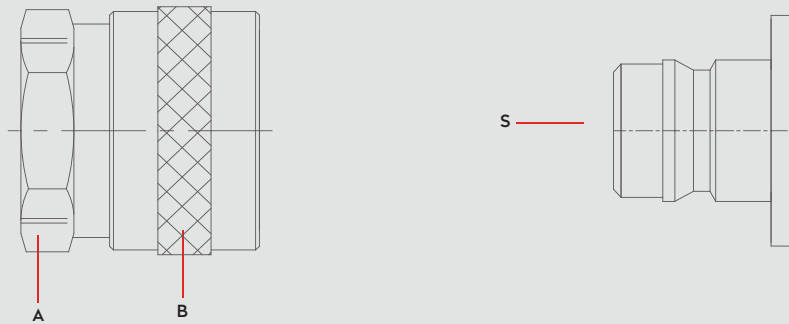

Material Code

- A = Brass Chrome Plated
- B = Brass Chrome Plated
- S = Brass Chrome Plated



0 - 25 bar



-40° to + 105°C (NBR)

Shut Off Type



OM 300 - 02550
CON - 3050 - 2050 - 40

FULL FLOW

DN 20 mm

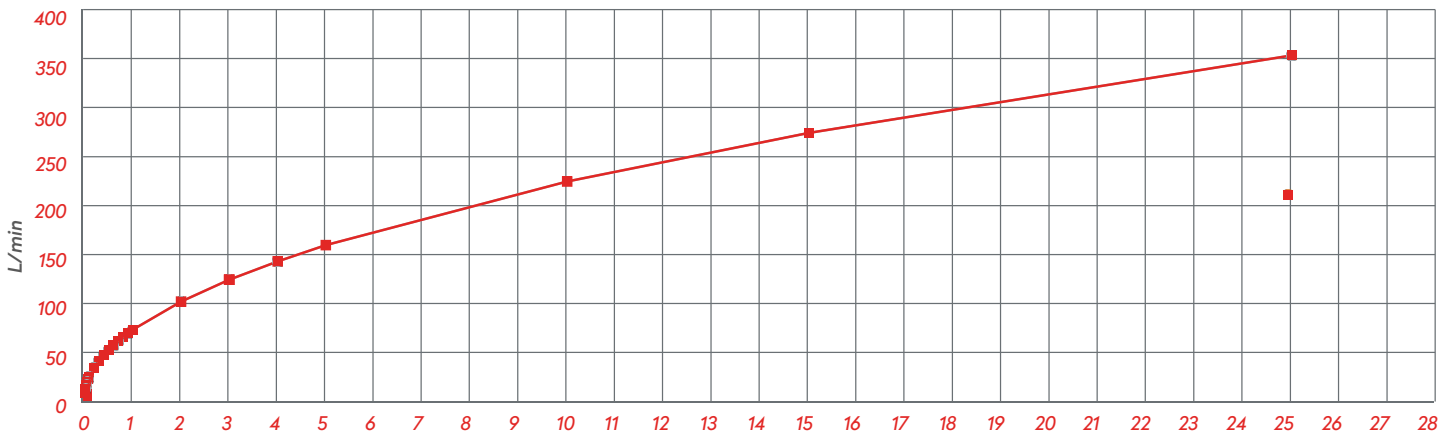

Options

FPM

AISI316
Stainless Steel

Plug Profile Serie 161

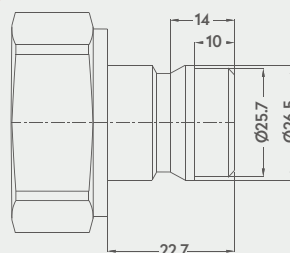

Compatible with

DYROS 3000
NITO

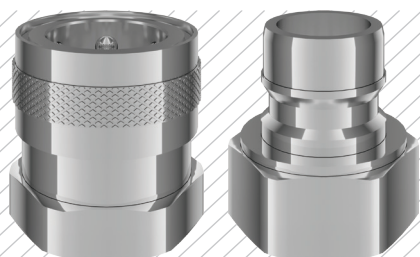
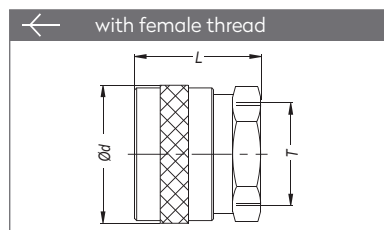
UNVALVED QUICK COUPLINGS SCHNELLKUPPLUNGEN OHNE VENIL

Connection	Part No.	ØD	L
BSP 1"	161 DGF 33	42,3	40

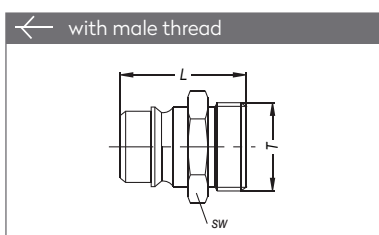
PLUGS STECKNIPPEL

Connection	Part No.	L	SW
BSP 1"	161 EU 33	42	36

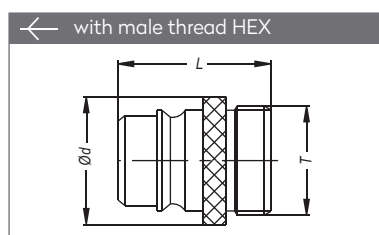

Connection	Part No.	SW	L
BSP 1"	161 EU 33 - 01	36	40,5

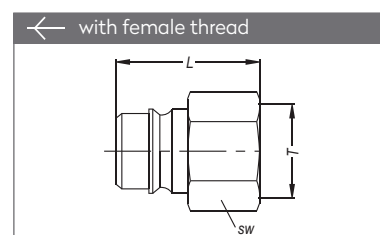

Connection	Part No.	SW	L
BSP 1"	161 DU 33	36	40

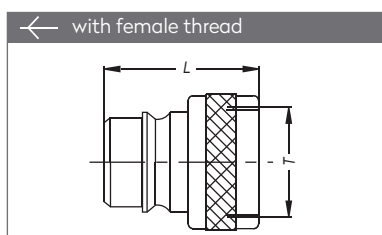

Connection	Part No.	ØD	L
BSP 1"	161 DU 33 - 01	36	40

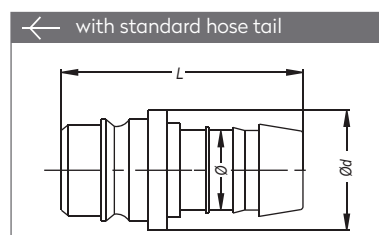

Connection	Part No.	ØD	L
Ø 19	161 HU 19	30	63,5
Ø 25	161 HU 25	35	63,5

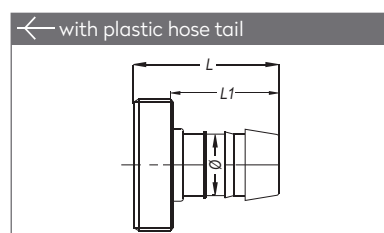
ADAPTER ADAPTER

Connection	Part No.	L	L1
BSP 1" - Ø 25	161 GU 25	44	32

MULTI PURPOSE COUPLINGS

MEHRFACHE ANWENDUNGEN

DN 6-51

SERIE 165

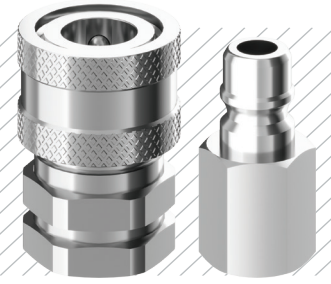

Materials

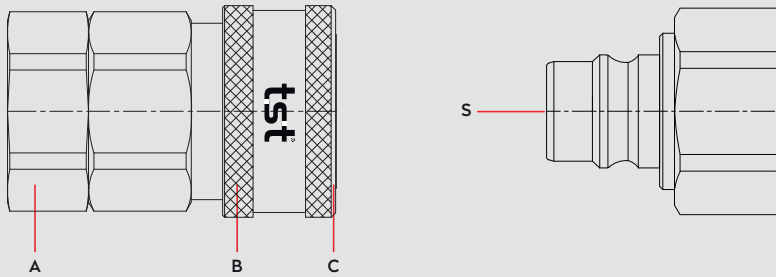

Material Code

- A = Brass
- B = Brass
- C = Brass
- S = Brass



Shut-off Socket & Shut Off Plug / Shut-off Socket & Thru-Flow Plug



Thru-Flow Socket & Thru-Flow Plug

Body Size Größe	Steel Stahl	Brass Messing	Stainless Steel Edelstahl	Steel Stahl	Brass Messing	Stainless Steel Edelstahl
	Bar	Bar	Bar	Bar	Bar	Bar
1/4" - 6.5 mm	448	155	345	759	276	690
3/8" - 10 mm	310	155	276	759	276	552
1/2" - 13 mm	276	168	259	759	276	552
3/4" - 19 mm	241	138	138	621	241	483
1" - 25 mm	138	121	138	414	207	276
1 1/4" - 31 mm	121	24	103	345	69	207
1 1/2" - 38 mm	103	24	103	345	69	207
2" - 51 mm	103	28	34	276	52	69

Shut Off Type

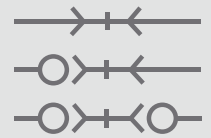

DN

6 - 32 mm



-40°C to + 105°C (NBR)

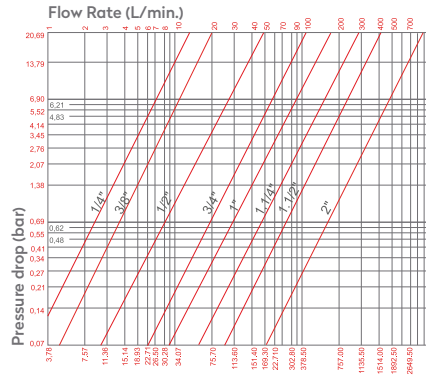
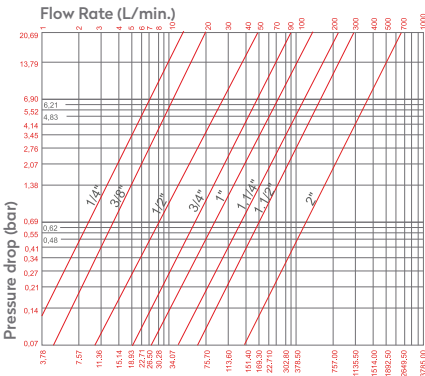

Options

STEEL	FPM	NPT	E3
NICKEL	EPDM	AISI303 Stainless Steel	AISI316 Stainless Steel

Applications

- General Purpose

Compatible with

- SNAP - TITE
- H serie

MULTI PURPOSE COUPLINGS
 MEHRFACHE ANWENDUNGEN

SERIE 165

QUICK COUPLINGS SCHNELLKUPPLUNGEN

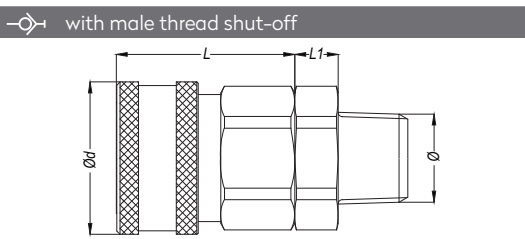

with Valve	Ø	with Valve	Ø	DN	L	L1	Ød	SW
165.04 RGB 13	BSPT 1/4"	165.04 TGB 13	NPT 1/4"	04-6.5 mm	34	7	25.7	22
165.06 RGB 17	BSPT 3/8"	165.06 TGB 17	NPT 3/8"	06-10 mm	38	6	31	24
165.08 RGB 21	BSPT 1/2"	165.08 TGB 21	NPT 1/2"	08-13 mm	41	10	35	30
165.12 RGB 26	BSPT 3/4"	165.12 TGB 26	NPT 3/4"	12-19 mm	48.7	10	42	36
165.16 RGB 33	BSPT 1"	165.16 TGB 33	NPT 1"	16-25 mm	52.5	15	50	50
165.20 RGB 42	BSPT 1 1/4"	165.20 TGB 42	NPT 1 1/4"	20-31 mm	58	9.3	50	50
165.24 RGB 48	BSPT 1 1/2"	165.24 TGB 48	NPT 1 1/2"	24-38 mm	65.2	18	69.9	66
165.32 RGB 60	BSPT 2"	165.32 TGB 60	NPT 2"	32-51 mm	80	17.6	90	88

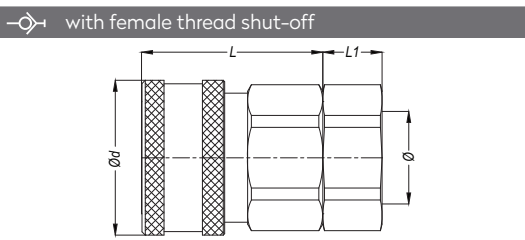

with Valve	Ø	with Valve	Ø	DN	L	L1	Ød	SW
165.04 DGB 13	BSP 1/4"	165.04 NGB 13	NPT 1/4"	04-6.5 mm	34.1	9.8	25.7	22
165.06 DGB 17	BSP 3/8"	165.06 NGB 17	NPT 3/8"	06-10 mm	38	15	31	24
165.08 DGB 21	BSP 1/2"	165.08 NGB 21	NPT 1/2"	08-13 mm	41	13.5	35	30
165.12 DGB 26	BSP 3/4"	165.12 NGB 26	NPT 3/4"	12-19 mm	48.7	14.5	42	36
165.16 DGB 33	BSP 1"	165.16 NGB 33	NPT 1"	16-25 mm	52.5	15.5	50	50
165.20 DGB 42	BSP 1 1/4"	165.20 NGB 42	NPT 1 1/4"	20-31 mm	58	26.8	55	50
165.24 DGB 48	BSP 1 1/2"	165.24 NGB 48	NPT 1 1/2"	24-38 mm	65.2	18	70	64
165.32 DGB 60	BSP 2"	165.32 NGB 60	NPT 2"	32-51 mm	79.8	20	89	86

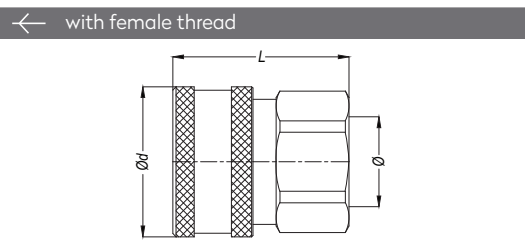

Without Valve	Ø	DN	L	Without Valve	Ø	L	Ød	SW
165.04 DGF 13	BSP 1/4"	04-6.5 mm	34.1	165.04 NGF 13	NPT 1/4"	34.1	25.7	22
165.06 DGF 17	BSP 3/8"	06-10 mm	38	165.06 NGF 17	NPT 3/8"	38	31	24
165.08 DGF 21	BSP 1/2"	08-13 mm	41	165.08 NGF 21	NPT 1/2"	41	35	30
165.12 DGF 26	BSP 3/4"	12-19 mm	48.7	165.12 NGF 26	NPT 3/4"	48.7	42	36
165.16 DGF 33	BSP 1"	16-25 mm	49.5	165.16 NGF 33	NPT 1"	49.5	50	50
165.20 DGF 42	BSP 1 1/4"	20-31 mm	58	165.20 NGF 42	NPT 1 1/4"	58	55	50
165.24 DGF 48	BSP 1 1/2"	24-38 mm	65.2	165.24 NGF 48	NPT 1 1/2"	65.2	70	63
165.32 DGF 60	BSP 2"	32-51 mm	63	165.32 NGF 60	NPT 2"	70	89	82

PLUGS STECKNIPPEL

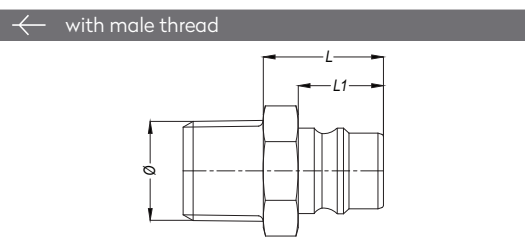

Without Valve	Ø	Without Valve	Ø	DN	L	L1	SW
165.04 RU 13	BSPT 1/4"	165.04 TU 13	NPT 1/4"	04-6.5 mm	21	15	16
165.06 RU 17	BSPT 3/8"	165.06 TU 17	NPT 3/8"	06-10 mm	26.4	18.4	19
165.08 RU 21	BSPT 1/2"	165.08 TU 21	NPT 1/2"	08-13 mm	25.5	18.1	24
165.12 RU 26	BSPT 3/4"	165.12 TU 26	NPT 3/4"	12-19 mm	32.6	22.6	30
165.16 RU 33	BSPT 1"	165.16 TU 33	NPT 1"	16-25 mm	39	23	38
165.20 RU 42	BSPT 1 1/4"	165.20 TU 42	NPT 1 1/4"	20-31 mm	32.6	23.3	50
165.24 RU 48	BSPT 1 1/2"	165.24 TU 48	NPT 1 1/2"	24-38 mm	34	27.3	54
165.32 RU 60	BSPT 2"	165.32 TU 60	NPT 2"	32-51 mm	51.6	34	63

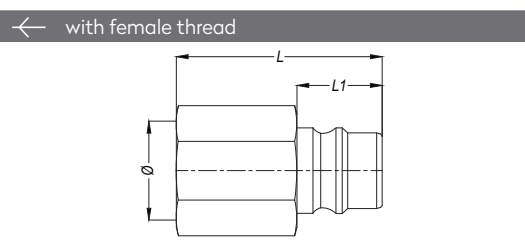

Without Valve	Ø	Without Valve	Ø	DN	L	L1	SW
165.04 DU 13	BSP 1/4"	165.04 NU 13	NPT 1/4"	04-6.5 mm	32.7	15	16
165.06 DU 17	BSP 3/8"	165.06 NU 17	NPT 3/8"	06-10 mm	36.6	18.4	24
165.08 DU 21	BSP 1/2"	165.08 NU 21	NPT 1/2"	08-13 mm	37.5	18.1	25
165.12 DU 26	BSP 3/4"	165.12 NU 26	NPT 3/4"	12-19 mm	44	22.6	30
165.16 DU 33	BSP 1"	165.16 NU 33	NPT 1"	16-25 mm	54	23	38
165.20 DU 42	BSP 1 1/4"	165.20 NU 42	NPT 1 1/4"	20-31 mm	54	23.3	50
165.24 DU 48	BSP 1 1/2"	165.24 NU 48	NPT 1 1/2"	24-38 mm	62	27.3	54
165.32 DU 60	BSP 2"	165.32 NU 60	NPT 2"	32-51 mm	66	34	70

MOULD COUPLINGS

KUPPLUNGEN FÜR WERKZEUGE

SERIE 165

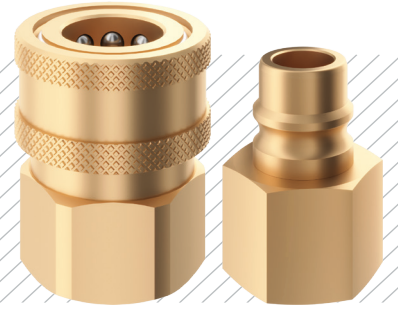

PLUGS STECKNIPPEL

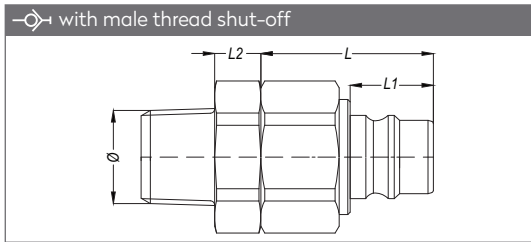

with male thread shut-off			with female thread shut-off						
/ With Valve	Ø	L2	/ With Valve	DN	Ø	L	L1	L2	SW
165.04 RUB 13	BSPT 1/4"	19	165.04 TUB 13	04-6.5 mm	NPT 1/4"	32.7	15	20	22
165.06 RUB 17	BSPT 3/8"	19	165.06 TUB 17	06-10 mm	NPT 3/8"	36.6	18.4	19	24
165.08 RUB 21	BSPT 1/2"	26	165.08 TUB 21	08-13 mm	NPT 1/2"	37.5	18.3	27	30
165.12 RUB 26	BSPT 3/4"	28	165.12 TUB 26	12-19 mm	NPT 3/4"	45.5	22.6	29	36
165.16 RUB 33	BSPT 1"	38	165.16 TUB 33	16-25 mm	NPT 1"	50	23	-	50
165.20 RUB 42	BSPT 1 1/4"	33.3	165.20 TUB 42	20-31 mm	NPT 1 1/4"	55	23.3	-	50
165.24 RUB 48	BSPT 1 1/2"	42	165.24 TUB 48	24-38 mm	NPT 1 1/2"	60.8	27.3	-	64
165.32 RUB 60	BSPT 2"	-	165.32 TUB 60	32-51 mm	NPT 2"	74.5	34	-	86

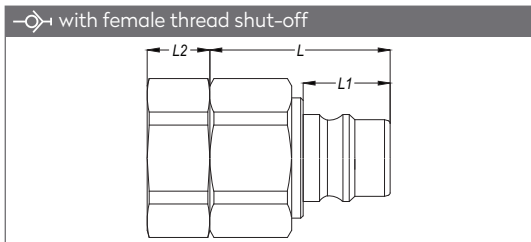

with female thread shut-off			with male thread shut-off						
/ With Valve	Ø	L2	/ With Valve	DN	Ø	L	L1	L2	SW
165.04 DUB 13	BSP 1/4"	9.8	165.04 NUB 13	04-6.5 mm	NPT 1/4"	32.7	15	9.8	22
165.06 DUB 17	BSP 3/8"	15	165.06 NUB 17	06-10 mm	NPT 3/8"	36.6	18.4	19	24
165.08 DUB 21	BSP 1/2"	13.5	165.08 NUB 21	08-13 mm	NPT 1/2"	37.5	18.3	13.5	30
165.12 DUB 26	BSP 3/4"	14.5	165.12 NUB 26	12-19 mm	NPT 3/4"	45.5	22.6	14.5	36
165.16 DUB 33	BSP 1"	15.5	165.16 NUB 33	16-25 mm	NPT 1"	50	23	20.5	50
165.20 DUB 42	BSP 1 1/4"	26.8	165.20 NUB 42	20-31 mm	NPT 1 1/4"	55	23.3	31.8	50
165.24 DUB 48	BSP 1 1/2"	18	165.24 NUB 48	24-38 mm	NPT 1 1/2"	60.8	27.3	18	64
165.32 DUB 60	BSP 2"	20	165.32 NUB 60	32-51 mm	NPT 2"	74.5	34	25	86



Part no.	DN
165.04 KG 00	04-6.5 mm
165.06 KG 00	06-10 mm
165.08 KG 00	08-13 mm
165.12 KG 00	12-19 mm
165.16 KG 00	16-25 mm
165.20 KG 00	20-31 mm
165.24 KG 00	24-38 mm
165.32 KG 00	32-51 mm

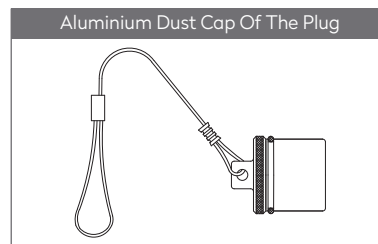

Part no.	DN
165.04 KU 00	04-6.5 mm
165.06 KU 00	06-10 mm
165.08 KU 00	08-13 mm
165.12 KU 00	12-19 mm
165.16 KU 00	16-25 mm
165.20 KU 00	20-31 mm
165.24 KU 00	24-38 mm
165.32 KU 00	32-51 mm

WATER COUPLINGS
WASSERKUPPLUNGEN

DN 4-19 SERIE 271



Materials

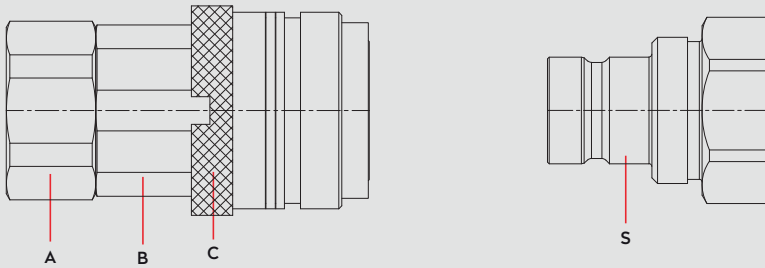

Material Code

- A = Brass Nickel Plated
- B = Brass Nickel Plated
- C = Brass Nickel Plated
- S = Brass Nickel Plated

0 - 20 bar

-40°C to +105°C (NBR)

Shut Off Type

DN	4 mm - 1/4"	6 mm - 3/8"	9 mm - 1/2"	14 mm - 3/4"	19 mm - 1"
FLOW	15 lt/min	20 lt/min	35 lt/min	100 lt/min	310 lt/min

DN 4 - 19 mm

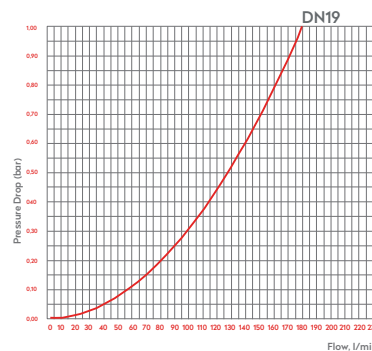
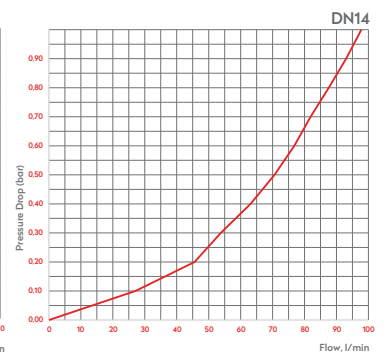
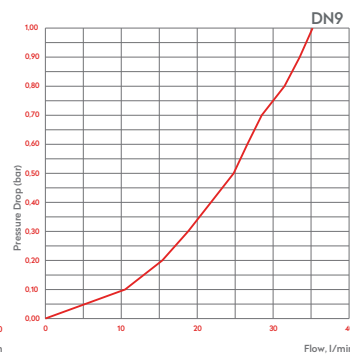
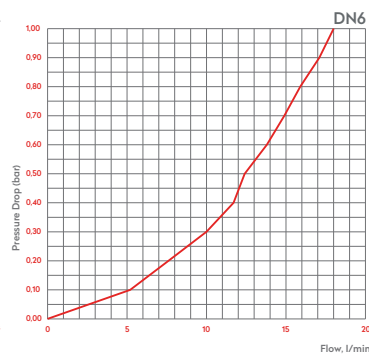
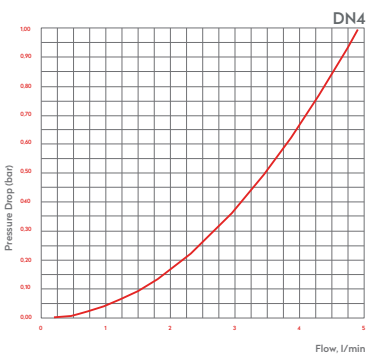

Options

E1	FPM
AISI316 Stainless Steel	EPDM



Compatible with

- BRASS**
CEJN 267, 467, 567, 667, 767
- STAINLESS STEEL**
CEJN 277, 477, 577, 677, 777



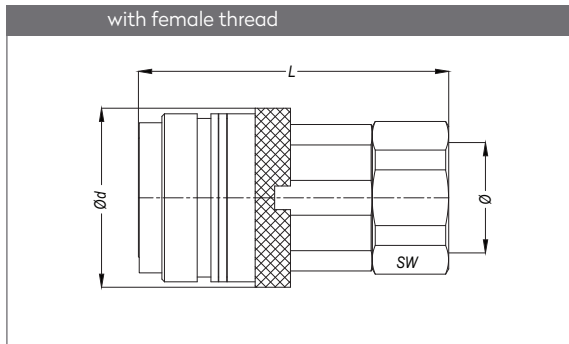

QUICK COUPLINGS SCHNELLKUPPLUNGEN

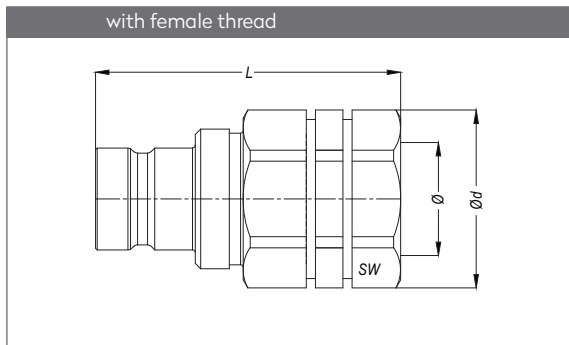

 With Valve	 Full Flow	Ø	SW	Ød	L
271.04 DGB 13	271.04 DGF 13	BSP 1/4"	19	23	43.5
271.06 DGB 17	271.06 DGF 17	BSP 3/8"	22	29.2	45
271.09 DGB 21	271.09 DGF 21	BSP 1/2"	27	34	59
271.14 DGB 26	271.14 DGF 26	BSP 3/4"	36	41	74.3
271.19 DGB 33	271.19 DGF 33	BSP 1"	46	52	82

PLUGS STECKNIPPEL



 With Valve	 Full Flow	Ø	SW	Ød	L
271.04 DUB 13	271.04 DU 13	BSP 1/4"	19	20	48.6
271.06 DUB 17	271.06 DU 17	BSP 3/8"	22	24	52
271.09 DUB 21	271.09 DU 21	BSP 1/2"	27	29	56.6
271.14 DUB 26	271.14 DU 26	BSP 3/4"	34	36	66
271.19 DUB 33	271.19 DU 33	BSP 1"	41	44	67.6

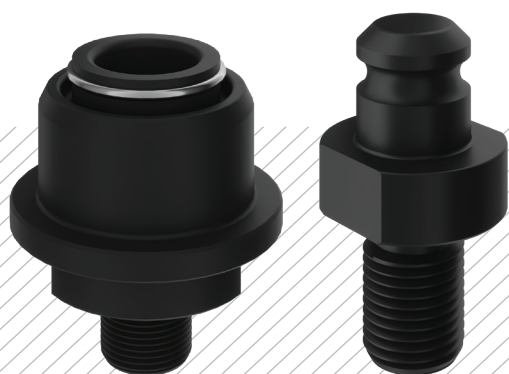

EJECTOR COUPLINGS

AUSWERFERKUPPLUNGEN

SERIE 300

Materials

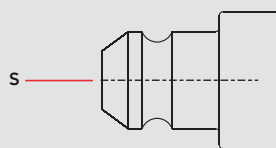
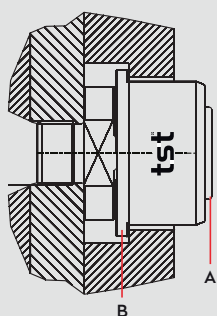

Material Code

A = Steel Hardened

B = Steel Hardened

S = Steel Hardened

QUICK COUPLINGS SCHNELLKUPPLUNGEN

with male thread

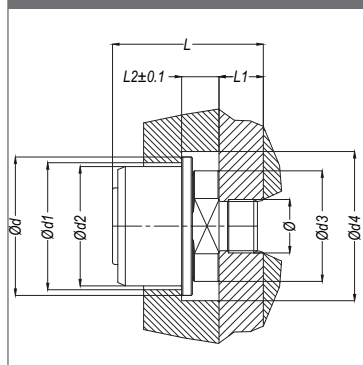

Part No.	Ø	Ød	Ød2	Ød3	Ød	Ød4	L	L1	L2	Pull Force kg
300.01 EGM 12x1.75 - E2	M12x1.75	34	32	32	39	44	42.5	15	9	1500
300.01 EGM 16 - E2	M16x1.5	34	32	32	39	44	42.5	15	9	1500
300.02 EGM 16 - E2	M16x1.5	40	38	38	48	53	52	15	13	2400
300.02 EGM 16x2.0 - E2	M16x2.0	40	38	38	48	53	52	15	13	2400
300.03 EGM 16 - E2	M16x1.5	58	56	52.5	65	70	68	18	17	3200
300.03 EGM 18 - E2	M18x1.5	58	56	52.5	65	70	68	18	17	3200
300.03 EGM 20 - E2	M20x1.5	58	56	52.5	65	70	68	18	17	3200
300.03 EGM 24 - E2	M24x1.5	58	56	52.5	65	70	68	18	17	3200
300.03 EGM 27 - E2	M27x1.5	58	56	52.5	65	70	68	18	17	3200
300.03 EGM 30 - E2	M30x1.5	58	56	52.5	65	70	68	18	17	3200

PLUGS STECKNIPPEL

with male thread

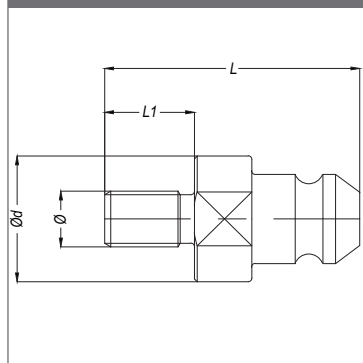

Part No.	Ø	Ød	L	L1
300.01 EUM 10x1.5	M10x1.5	22.8	45.5	20
300.01 EUM 12x1.75	M12x1.75	22.8	45.5	20
300.01 EUM 14x2.0	M14x2.0	22.8	45.5	20
300.01 EUM 16x2.0	M16x2.0	22.8	45.5	20
300.02 EUM 10x1.5	M10x1.5	25.8	55	20
300.02 EUM 12x1.75	M12x1.75	25.8	55	20
300.02 EUM 14x2.0	M14x2.0	25.8	55	20
300.02 EUM 16x2.0	M16x2.0	25.8	55	20
300.03 EUM 16x2.0	M16x2.0	35.35	68	25
300.03 EUM 18x2.5	M18x2.5	35.35	68	25
300.03 EUM 20x2.5	M20x2.5	35.35	68	25
300.03 EUM 24x3.0	M24x3.0	35.35	68	25
300.03 EUM 27x3.0	M27x3.0	35.35	68	25
300.03 EUM 30x3.5	M30x3.5	35.35	68	25

Applications

Quick mould change

Compatible with

Alba

Materials

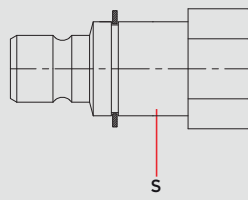
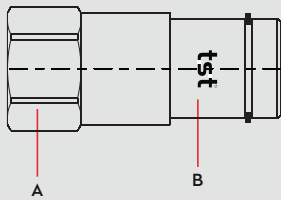

Material Code

A = Brass

B = Brass

S = Brass



0 - 16 bar



-26°C to + 200°C (FPM)

Shut Off Type



COUPLING
OV 200 - 01300
OV 200 - 00900
OV 100 - 01300

PLUG
OV 157 - 00700

International Profile

DN 9 mm

Multi Couplings Systems for quick changing of injection moulding and die cast equipments

Multikupplungensysteme für schnelles Wechseln und Verbinden der Kokillen und Spritzgußformen

Options

NICKEL

COLOURED
PLATE

Applications

- Temperature controlling

Compatible with

12 ⇌ 12

SERIE 009M

Multi Couplings Systems for quick changing of injection moulding and die cast equipments

Multikupplungensysteme für schnelles Wechseln und Verbinden der Kokillen und Spritzgußformen

Machine Side

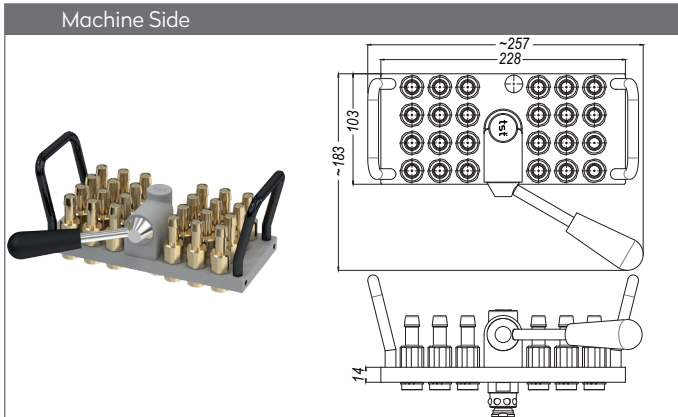

Mould Side

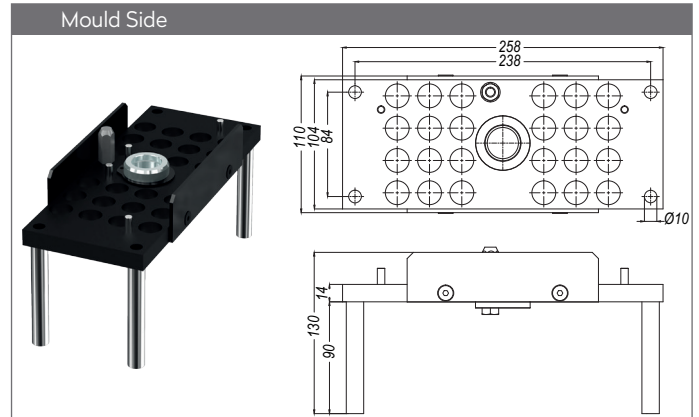

Part No.	Unit	Ø
MM009.24	-	without couplings
MM009.24 HGB 10	24	Hose tail 10 mm
MM009.24 HGB 12	24	Hose tail 12 mm
MM009.24 FGB 10	24	Push-Lock Hose tail 10 mm
MM009.24 FGB 13	24	Push-Lock Hose tail 13 mm
MM009.24 DGB 17	24	BSP female 3/8"
MM009.24 NGB 17	24	NPT female 3/8"

Part No.	Unit	Ø
MK009.24	-	without plugs
MK009.24 DUB 17	24	BSP female 3/8" with valve
MK009.24 NUB 17	24	NPT female 3/8" with valve
MK009.24 DU 17	24	BSP female 3/8" without valve
MK009.24 NU 17	24	NPT female 3/8" without valve

Machine Side with Collector

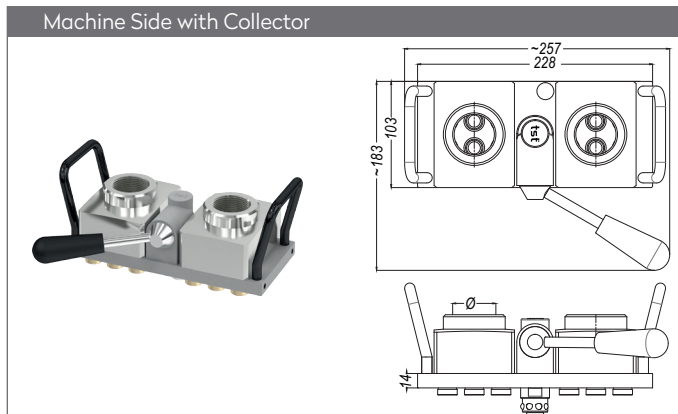

Parking Plate

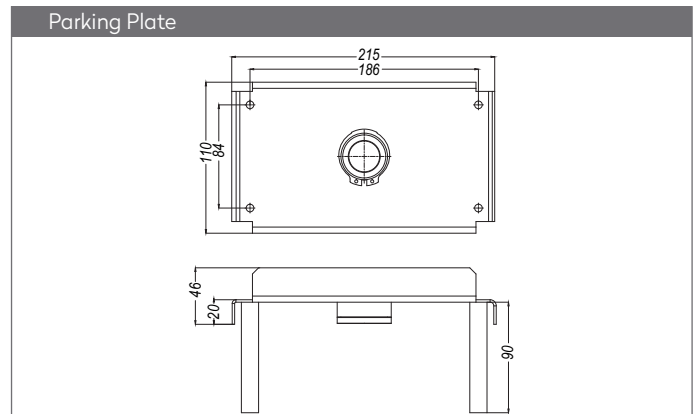

Part No.	Unit	Ø
MM009.24C	24	BSP female 1.1/4"
MM009.24CN	24	NPT female 1.1/4"

Part No.
MM109.24 P

10 ↔ 10

SERIE 009M

Multi Couplings Systems for quick changing of injection moulding and die cast equipments

Multikupplungensysteme für schnelles Wechseln und Verbinden der Kokillen und Spritzgußformen

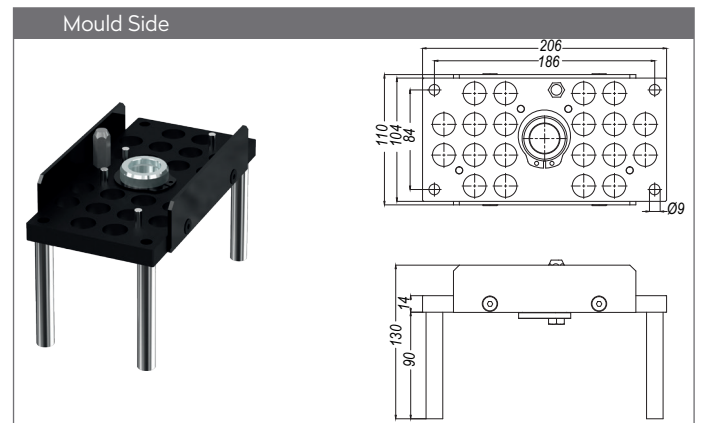
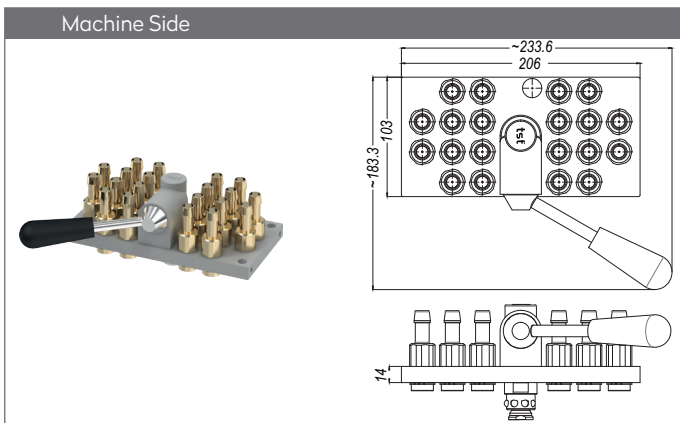

Part No.	Unit	Ø
MM009.20	-	without couplings
MM009.20 HGB 10	20	Hose tail 10 mm
MM009.20 HGB 12	20	Hose tail 12 mm
MM009.20 FGB 10	20	Push-Lock Hose tail 10 mm
MM009.20 FGB 13	20	Push-Lock Hose tail 13 mm
MM009.20 DGB 17	20	BSP female 3/8"
MM009.20 NGB 17	20	NPT female 3/8"

Part No.	Unit	Ø
MK009.20	-	without plugs
MK009.20 DUB 17	20	BSP female 3/8" with valve
MK009.20 NUB 17	20	NPT female 3/8" with valve
MK009.20 DU 17	20	BSP female 3/8" without valve
MK009.20 NU 17	20	NPT female 3/8" without valve

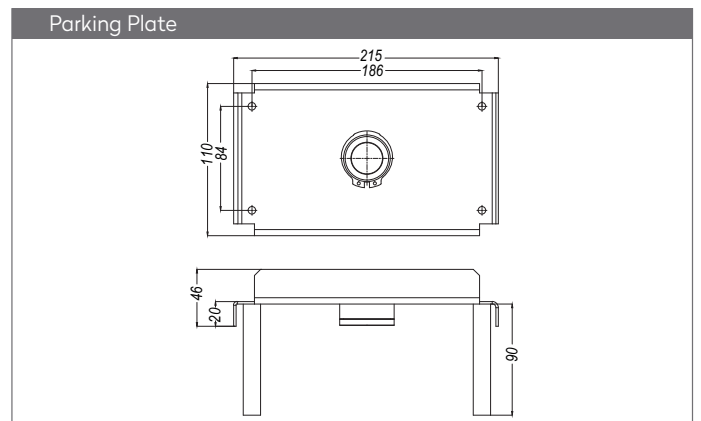
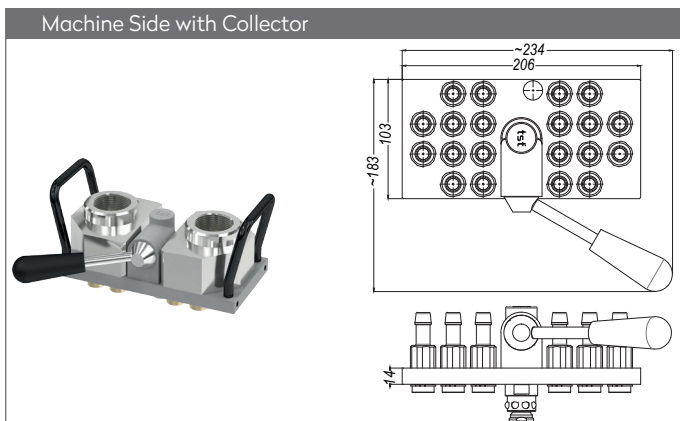

Part No.	Unit	Ø
MM009.20C	20	BSP female 1.1/4"
MM009.20CN	20	NPT female 1.1/4"

Part No.
MM109.24 P

MULTICOUPLINGS
 MULTIKUPPLUNGEN

8 ↔ 8

SERIE 009M

Multi Couplings Systems for quick changing of injection moulding and die cast equipments

Multikupplungensysteme für schnelles Wechseln und Verbinden der Kokillen und Spritzgußformen

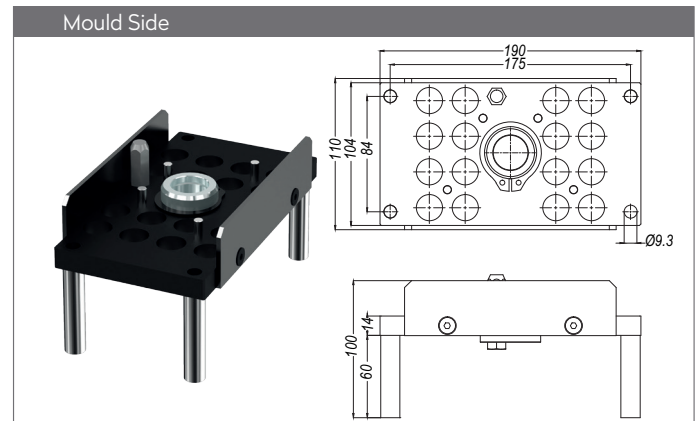
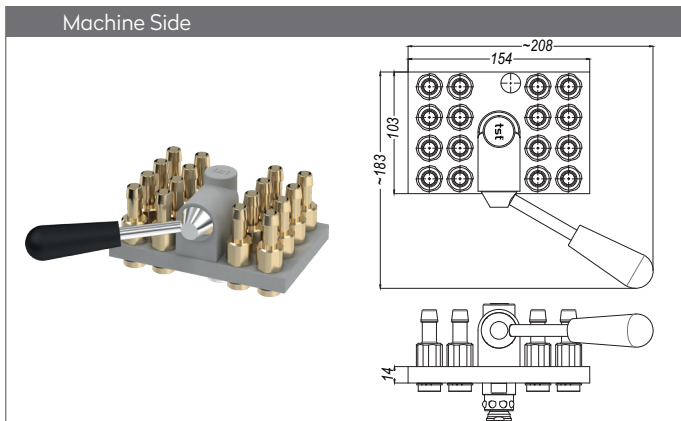

Part No.	Unit	Ø
MM009.16	-	without couplings
MM009.16 HGB 10	16	Hose tail 10 mm
MM009.16 HGB 12	16	Hose tail 12 mm
MM009.16 FGB 10	16	Push-Lock Hose tail 10 mm
MM009.16 FGB 13	16	Push-Lock Hose tail 13 mm
MM009.16 DGB 17	16	BSP female 3/8"
MM009.16 NGB 17	16	NPT female 3/8"

Part No.	Unit	Ø
MK009.16	-	without plugs
MK009.16 DUB 17	16	BSP female 3/8" with valve
MK009.16 NUB 17	16	NPT female 3/8" with valve
MK009.16 DU 17	16	BSP female 3/8" without valve
MK009.16 NU 17	16	NPT female 3/8" without valve

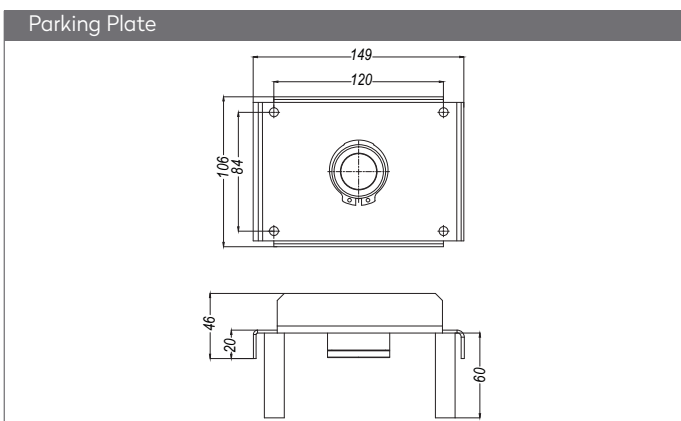

Part No.
MM109.16 P

MULTICOUPLINGS
MULTIKUPPLUNGEN

6 ↔ 6

SERIE 009M

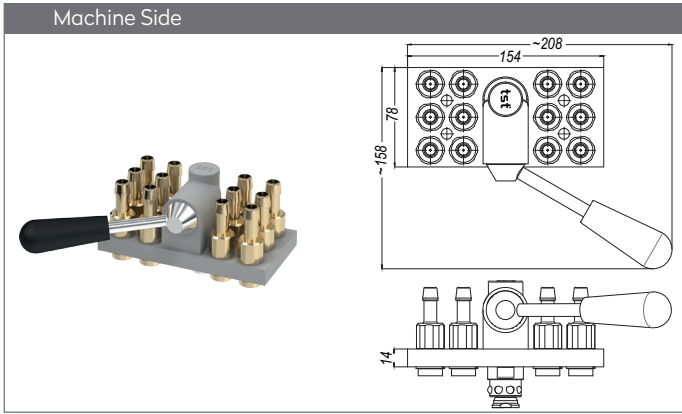

Part No.	Unit	Ø
MM009.12	-	without couplings
MM009.12 HGB 10	12	Hose tail 10 mm
MM009.12 HGB 12	12	Hose tail 12 mm
MM009.12 FGB 10	12	Push-Lock Hose tail 10 mm
MM009.12 FGB 13	12	Push-Lock Hose tail 13 mm
MM009.12 DGB 17	12	BSP female 3/8"
MM009.12 NGB 17	12	NPT female 3/8"

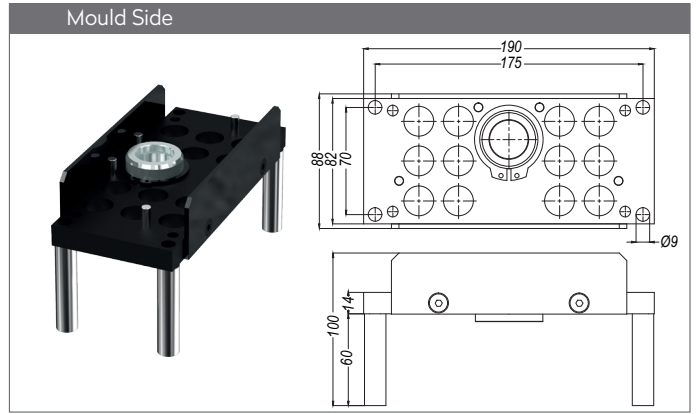

Part No.	Unit	Ø
MK009.12	-	without plugs
MK009.12 DUB 17	12	BSP female 3/8" with valve
MK009.12 NUB 17	12	NPT female 3/8" with valve
MK009.12 DU 17	12	BSP female 3/8" without valve
MK009.12 NU 17	12	NPT female 3/8" without valve

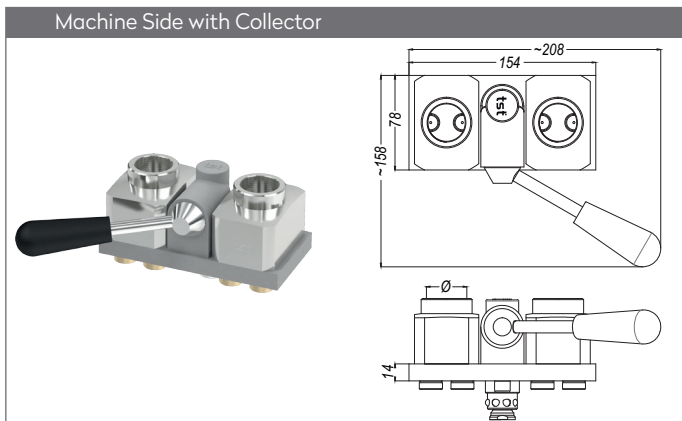

Part No.	Unit	Ø
MM009.12C	12	BSP female 1"
MM009.12CN	12	NPT female 1"

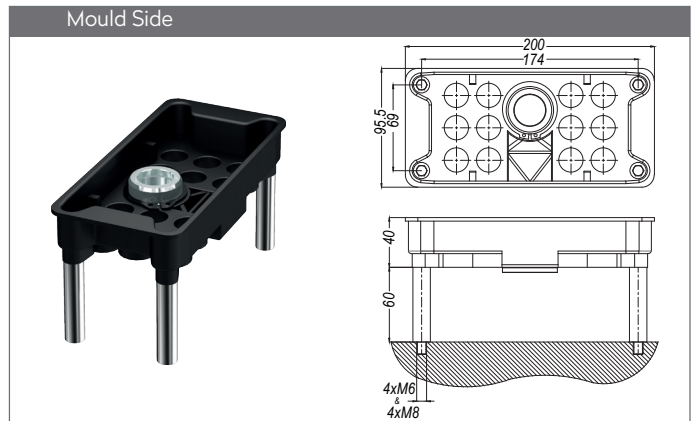

Part No.	Unit	Ø
MK009.12K	-	without plugs
MK009.12K DUB 17	12	BSP female 3/8" with valve
MK009.12K NUB 17	12	NPT female 3/8" with valve
MK009.12K DU 17	12	BSP female 3/8" without valve
MK009.12K NU 17	12	NPT female 3/8" without valve

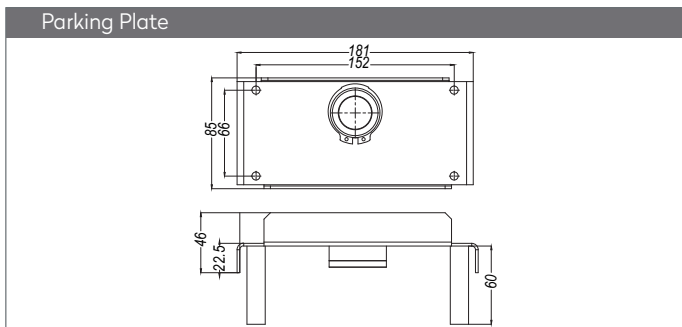

Part No.
MM109.12 P

MULTICOUPLINGS

MULTIKUPPLUNGEN

5 ↔ 5

SERIE 009M

Multi Couplings Systems for quick changing of injection moulding and die cast equipments

Multikupplungensysteme für schnelles Wechseln und Verbinden der Kokillen und Spritzgußformen

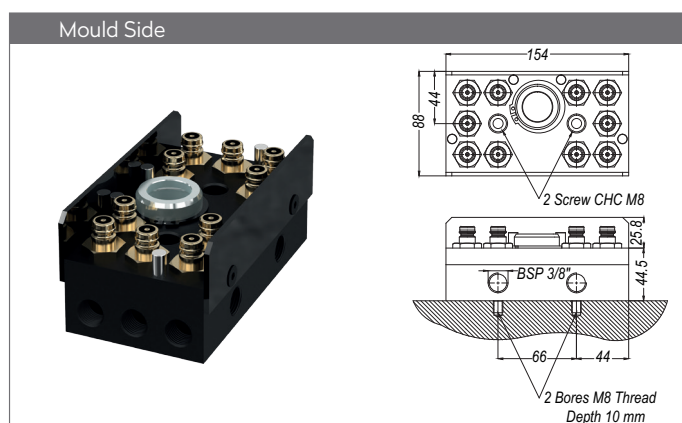
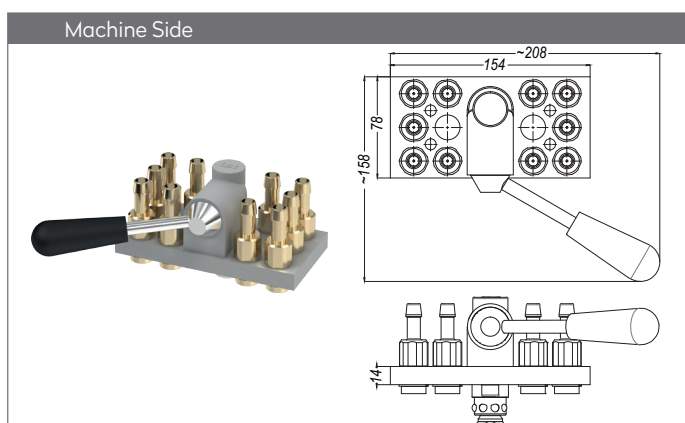

Part No.	Unit	Ø
MM009.12	-	without couplings
MM009.10 HGB 10	10	Hose tail 10 mm
MM009.10 HGB 12	10	Hose tail 12 mm
MM009.10 FGB 10	10	Push-Lock Hose tail 10 mm
MM009.10 FGB 13	10	Push-Lock Hose tail 13 mm
MM009.10 DGB 17	10	BSP female 3/8"
MM009.10 NGB 17	10	NPT female 3/8"

Part No.	Unit	Ø
MK009.10	10	BSP male 1/2" without valve
MK009.10 V	10	BSP male 1/2" with valve

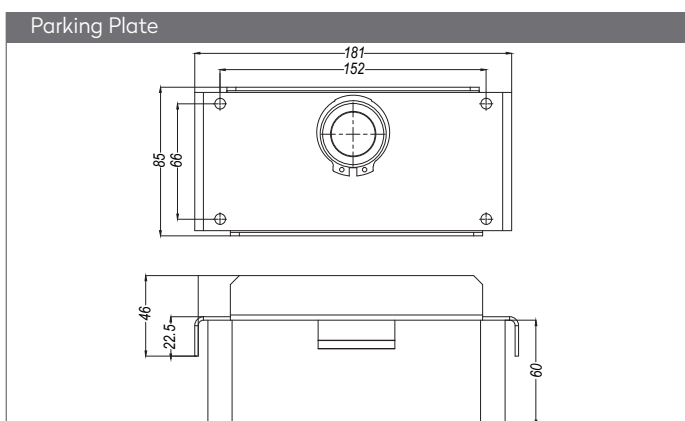

Part No.
MM109.12 P



SERIE 009M

Multi Couplings Systems for quick changing of injection moulding and die cast equipments

Multikupplungensysteme für schnelles Wechseln und Verbinden der Kokillen und Spritzgußformen

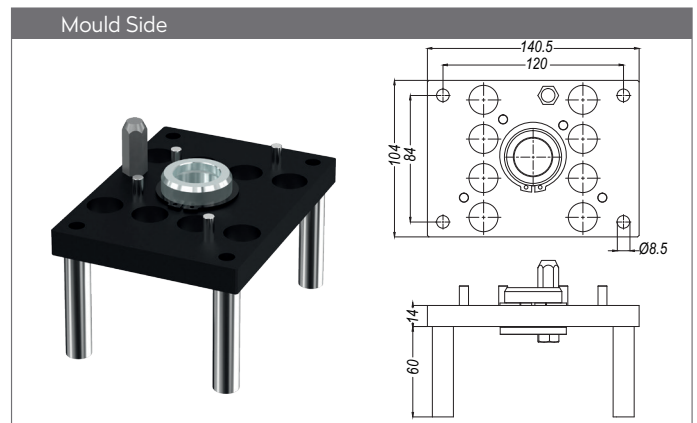
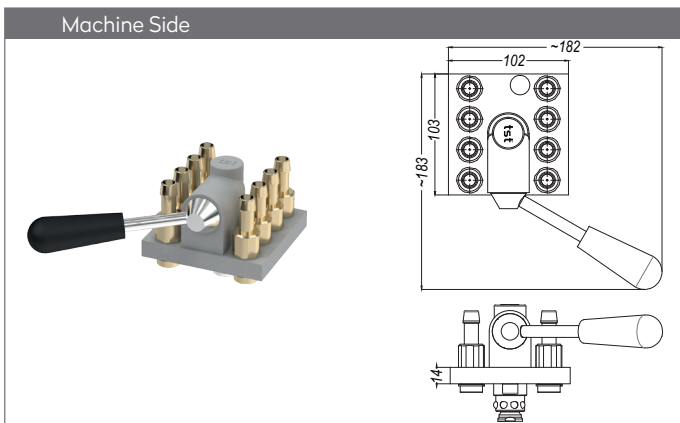

Part No.	Unit	Ø
MM009.08	-	without couplings
MM009.08 HGB 10	8	Hose tail 10 mm
MM009.08 HGB 12	8	Hose tail 12 mm
MM009.08 FGB 10	8	Push-Lock Hose tail 10 mm
MM009.08 FGB 13	8	Push-Lock Hose tail 13 mm
MM009.08 DGB 17	8	BSP female 3/8"
MM009.08 NGB 17	8	NPT female 3/8"

Part No.	Unit	Ø
MK009.08	-	without plugs
MK009.08 DUB 17	8	BSP female 3/8" with valve
MK009.08 NUB 17	8	NPT female 3/8" with valve
MK009.08 DU 17	8	BSP female 3/8" without valve
MK009.08 NU 17	8	NPT female 3/8" without valve

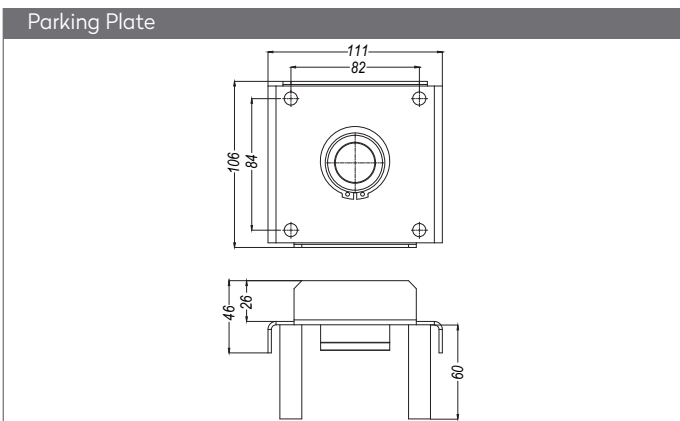

Part No.
MM109.08 P

MULTICOUPLINGS
 MULTIKUPPLUNGEN

3 ↔ 3

SERIE 009M

Multi Couplings Systems for quick changing of injection moulding and die cast equipments

Multikupplungensysteme für schnelles Wechseln und Verbinden der Kokillen und Spritzgußformen

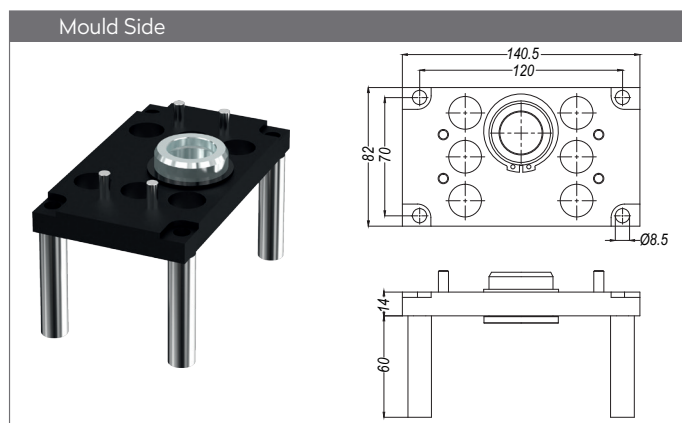
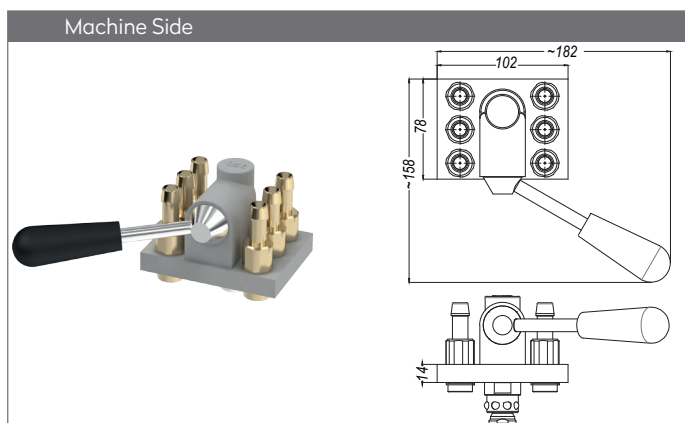

Part No.	Unit	Ø
MM009.06	-	without couplings
MM009.06 HGB 10	6	Hose tail 10 mm
MM009.06 HGB 12	6	Hose tail 12 mm
MM009.06 FGB 10	6	Push-Lock Hose tail 10 mm
MM009.06 FGB 13	6	Push-Lock Hose tail 13 mm
MM009.06 DGB 17	6	BSP female 3/8"
MM009.06 NGB 17	6	NPT female 3/8"

Part No.	Unit	Ø
MK009.06	-	without plugs
MK009.06 DUB 17	6	BSP female 3/8" with valve
MK009.06 NUB 17	6	NPT female 3/8" with valve
MK009.06 DU 17	6	BSP female 3/8" without valve
MK009.06 NU 17	6	NPT female 3/8" without valve

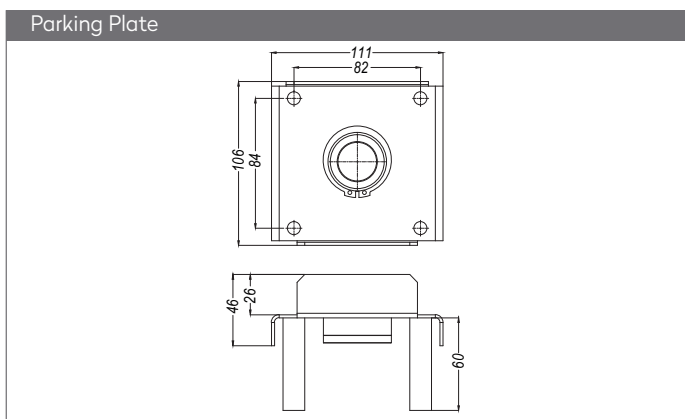

Part No.
MM109.08 P

MULTICOUPLINGS
MULTIKUPPLUNGEN

SERIE 009M

QUICK COUPLINGS SCHNELLKUPPLUNGEN

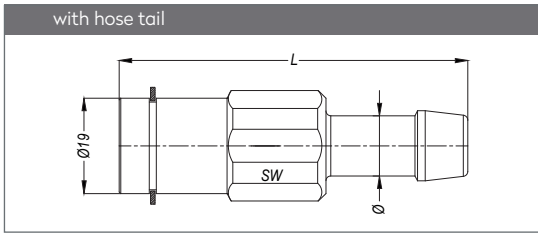

With Valve	Without Valve	SW	Ø	L
MM009 HGB 10	MM009 HGF 10	21	10	69.5
MM009 HGB 12	MM009 HGF 12	21	12	69.5

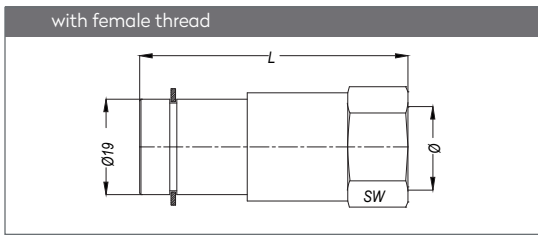

With Valve	Without Valve	SW	Ø	L
MM009 DGB 17	MM009 DGF 17	22	BSP 3/8"	53.5
MM009 NGB 17	MM009 NGF 17	22	NPT 3/8"	53.5

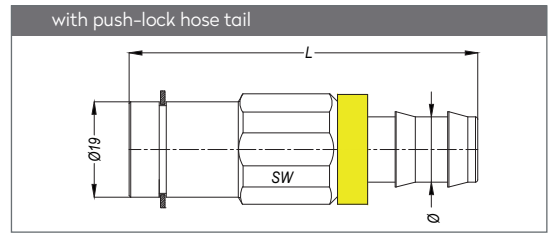

With Valve	Without Valve	SW	Ø	L
MM009 FGB 10	MM009 FGF 10	21	10	65.5
MM009 FGB 13	MM009 FGF 13	21	13	69.5

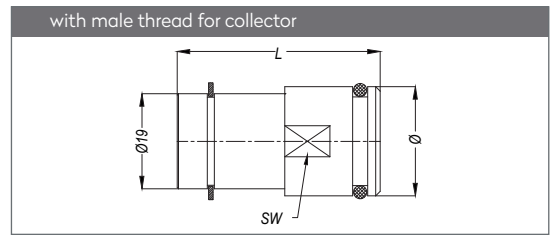

With Valve	Without Valve	SW	Ø	L
MM009 EGB 00	-	21	21.8	40.5

PLUGS STECKNIPPEL

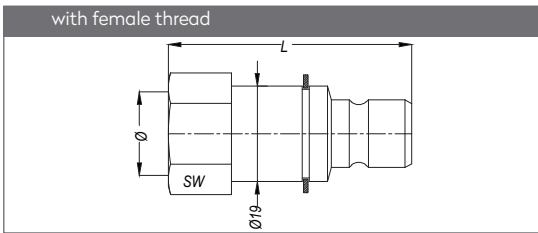

With Valve	Without Valve	SW	Ø	L
MK009 DUB 17	MK009 DUF 17	21	BSP 3/8"	47.7
MK009 NUB 17	MK009 NUF 17	21	NPT 3/8"	47.7

ACCESSORIES ZUBEHÖR

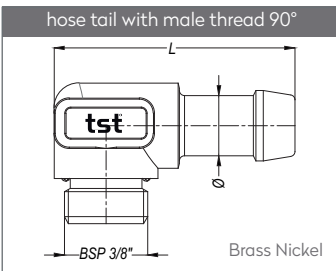

Part No.	Ø
109 EB 17.10	10
109 EB 17.13	13

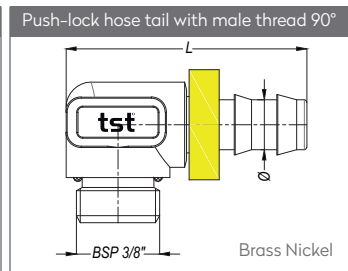

Part No.	Ø
109 EF 17.10	10
109 EF 17.13	13

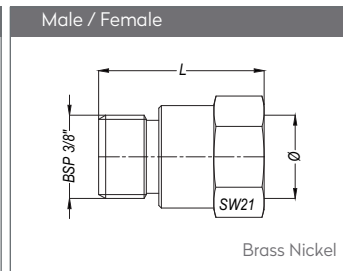

Part No.	Ø
109 EN 17	BSP 3/8"
109 NN 17	NPT 3/8"

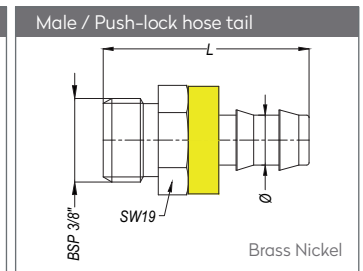

Part No.	Ø
EHF 17-10	10
EHF 17-13	13

DN9

MULTICOUPLINGS
MULTIKUPPLUNGEN

SERIE 090M

Materials

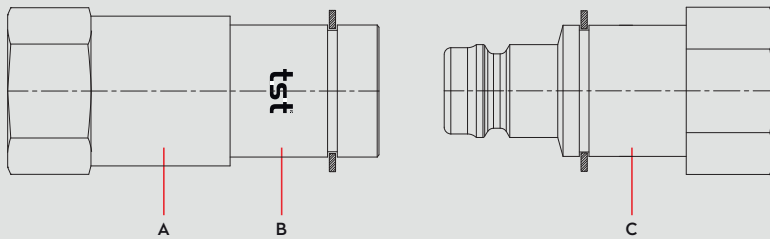

Material Code

A = Brass

B = Brass

C = Brass



0 - 16 bar



-26°C to + 200°C (FPM)

Shut Off Type



COUPLING	OV 200 - 01200
	OV 200 - 00900
PLUG	OV 100 - 01300
	OV 157 - 00700

European Profile

DN 9 mm

Multi Couplings Systems for quick changing of injection moulding and die cast equipments

Multikupplungensysteme für schnelles Wechseln und Verbinden der Kokillen und Spritzgußformen

Options

NICKEL

COLOURED
PLATE

Applications

- Temperature controlling

Compatible with

12 ⇔ 12

SERIE 090M

Multi Couplings Systems for quick changing of injection moulding and die cast equipments

Multikupplungensysteme für schnelles Wechseln und Verbinden der Kokillen und Spritzgußformen

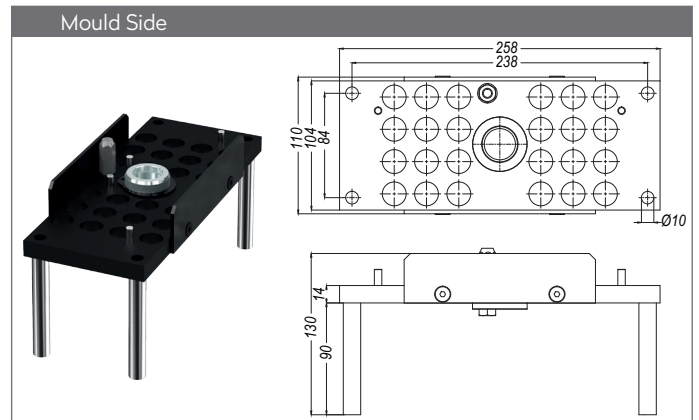
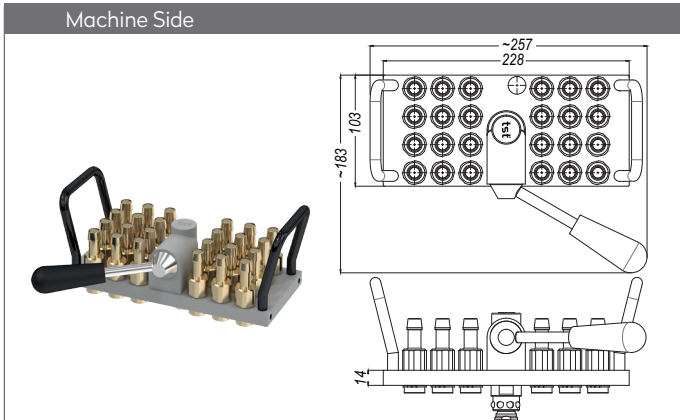

Part No.	Unit	Ø
MM090.24	-	without couplings
MM090.24 HGB 10	24	Hose tail 10 mm
MM090.24 HGB 12	24	Hose tail 12 mm
MM090.24 FGB 10	24	Push-Lock Hose tail 10 mm
MM090.24 FGB 13	24	Push-Lock Hose tail 13 mm
MM090.24 DGB 17	24	BSP female 3/8"
MM090.24 NGB 17	24	NPT female 3/8"

Part No.	Unit	Ø
MK090.24	-	without plugs
MK090.24 DUB 17	24	BSP female 3/8" with valve
MK090.24 NUB 17	24	NPT female 3/8" with valve
MK090.24 DU 17	24	BSP female 3/8" without valve
MK090.24 NU 17	24	NPT female 3/8" without valve

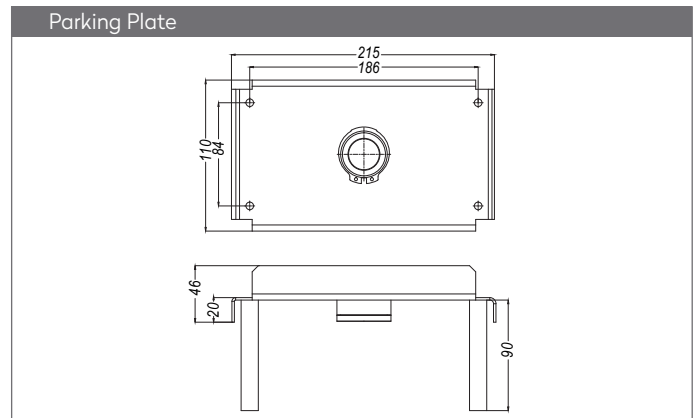
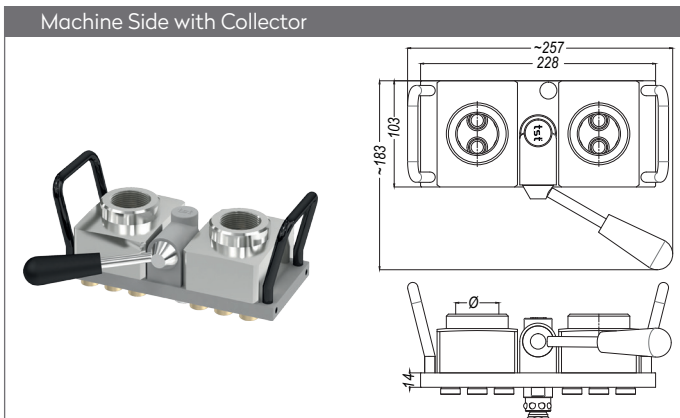

Part No.	Unit	Ø
MM090.24C	24	BSP female 1 1/4"
MM090.24CN	24	NPT female 1 1/4"

Part No.
MM109.24 P

MULTICOUPLINGS

MULTIKUPPLUNGEN

10 ↔ 10

SERIE 090M

Multi Couplings Systems for quick changing of injection moulding and die cast equipments

Multikupplungensysteme für schnelles Wechseln und Verbinden der Kokillen und Spritzgußformen

Machine Side

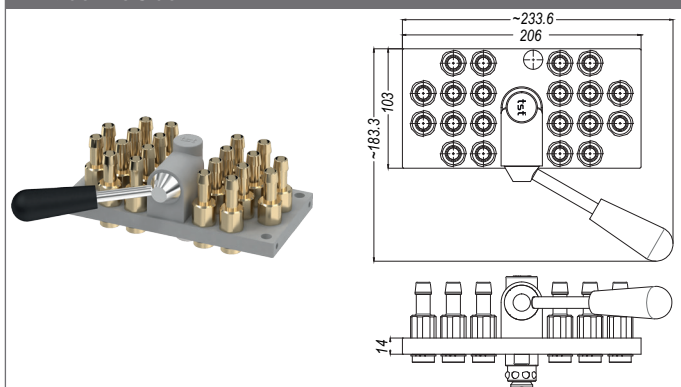

Mould Side

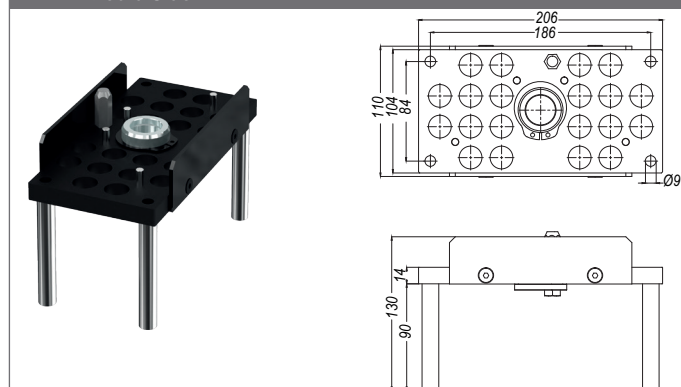

Part No.	Unit	Ø
MM090.20	-	without couplings
MM090.20 HGB 10	20	Hose tail 10 mm
MM090.20 HGB 12	20	Hose tail 12 mm
MM090.20 FGB 10	20	Push-Lock Hose tail 10 mm
MM090.20 FGB 13	20	Push-Lock Hose tail 13 mm
MM090.20 DGB 17	20	BSP female 3/8"
MM090.20 NGB 17	20	NPT female 3/8"

Part No.	Unit	Ø
MK090.20	-	without plugs
MK090.20 DUB 17	20	BSP female 3/8" with valve
MK090.20 NUB 17	20	NPT female 3/8" with valve
MK090.20 DU 17	20	BSP female 3/8" without valve
MK090.20 NU 17	20	NPT female 3/8" without valve

Machine Side with Collector

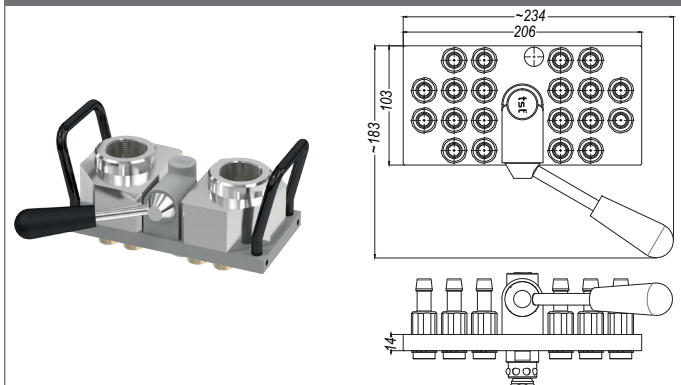

Parking Plate

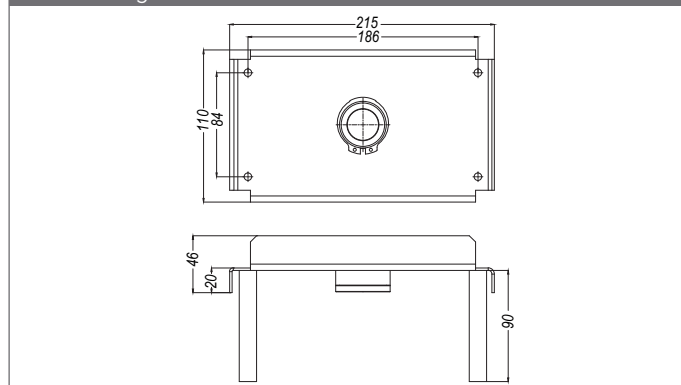

Part No.	Unit	Ø
MM090.20C	20	BSP female 1 1/4"
MM090.20CN	20	NPT female 1 1/4"

Part No.
MM109.24 P



SERIE 090M

Multi Couplings Systems for quick changing of injection moulding and die cast equipments

Multikupplungensysteme für schnelles Wechseln und Verbinden der Kokillen und Spritzgußformen

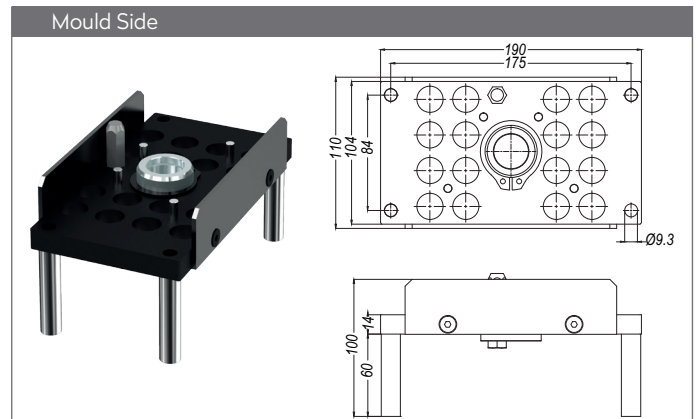
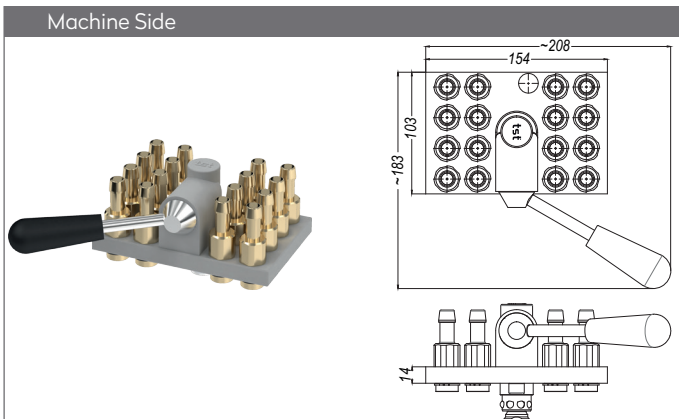

Part No.	Unit	Ø
MM090.16	-	without couplings
MM090.16 HGB 10	16	Hose tail 10 mm
MM090.16 HGB 12	16	Hose tail 12 mm
MM090.16 FGB 10	16	Push-Lock Hose tail 10 mm
MM090.16 FGB 13	16	Push-Lock Hose tail 13 mm
MM090.16 DGB 17	16	BSP female 3/8"
MM090.16 NGB 17	16	NPT female 3/8"

Part No.	Unit	Ø
MK090.16	-	without plugs
MK090.16 DUB 17	16	BSP female 3/8" with valve
MK090.16 NUB 17	16	NPT female 3/8" with valve
MK090.16 DU 17	16	BSP female 3/8" without valve
MK090.16 NU 17	16	NPT female 3/8" without valve

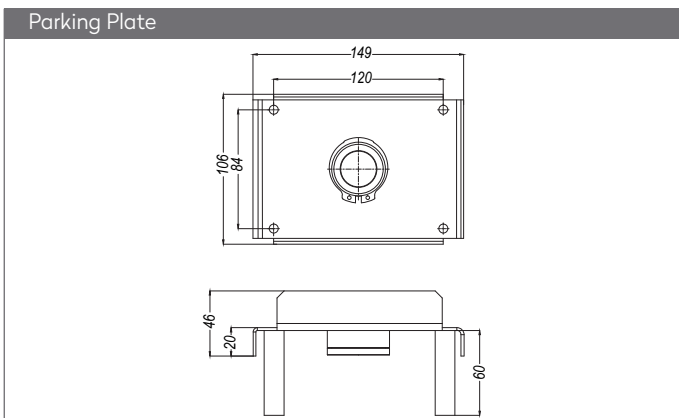

Part No.
MM109.16 P

MULTICOUPLINGS
 MULTIKUPPLUNGEN

6 ↔ 6

SERIE 090M

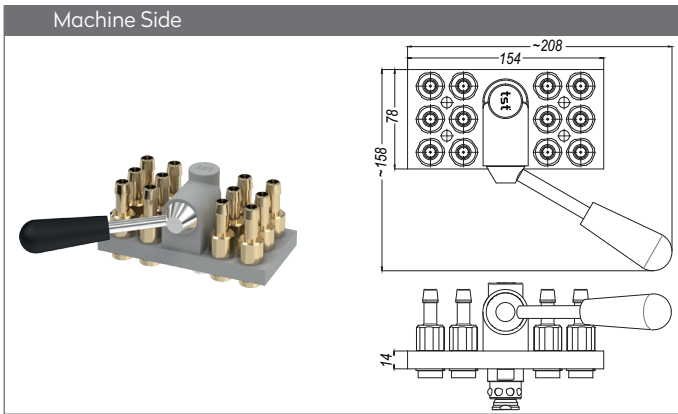

Part No.	Unit	Ø
MM090.12	-	without couplings
MM090.12 HGB 10	12	Hose tail 10 mm
MM090.12 HGB 12	12	Hose tail 12 mm
MM090.12 FGB 10	12	Push-Lock Hose tail 10 mm
MM090.12 FGB 13	12	Push-Lock Hose tail 13 mm
MM090.12 DGB 17	12	BSP female 3/8"
MM090.12 NGB 17	12	NPT female 3/8"

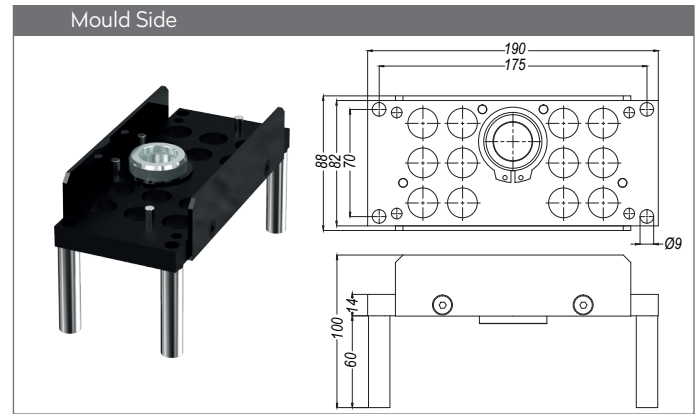

Part No.	Unit	Ø
MK090.12	-	without plugs
MK090.12 DUB 17	12	BSP female 3/8" with valve
MK090.12 NUB 17	12	NPT female 3/8" with valve
MK090.12 DU 17	12	BSP female 3/8" without valve
MK090.12 NU 17	12	NPT female 3/8" without valve

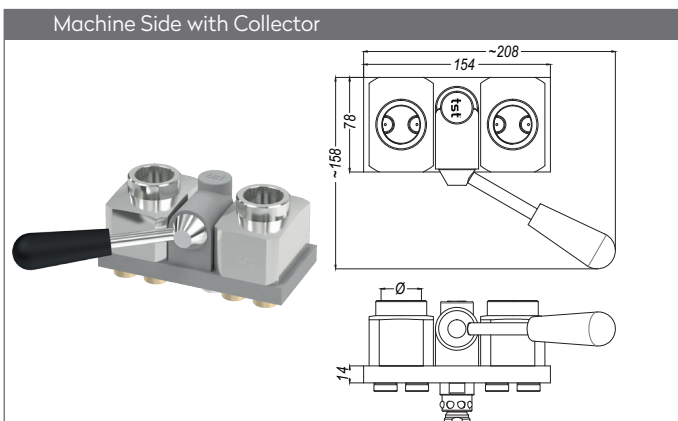

Part No.	Unit	Ø
MM090.12C	12	BSP female 1"
MM090.12CN	12	NPT female 1"

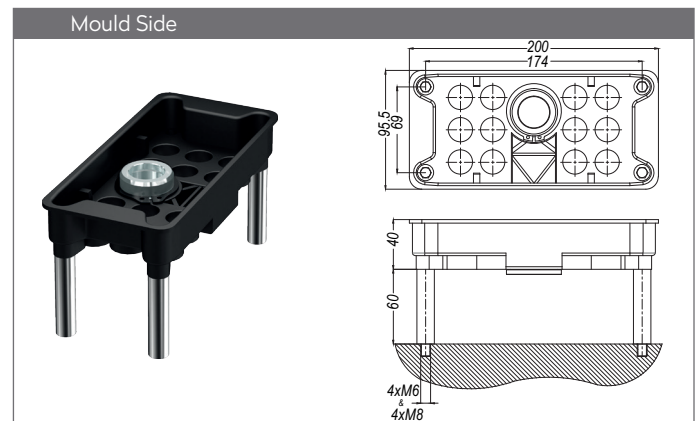

Part No.	Unit	Ø
MK090.12K	-	without plugs
MK090.12K DUB 17	12	BSP female 3/8" with valve
MK090.12K NUB 17	12	NPT female 3/8" with valve
MK090.12K DU 17	12	BSP female 3/8" without valve
MK090.12K NU 17	12	NPT female 3/8" without valve

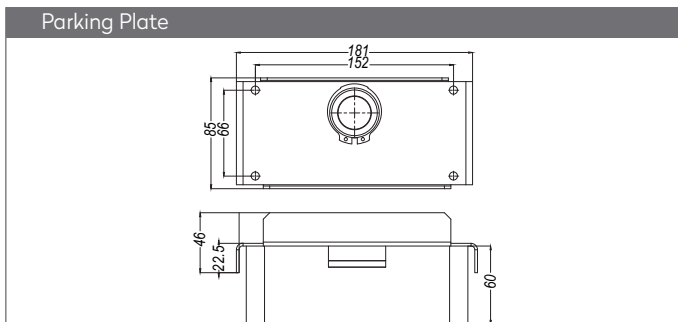

Part No.
MM109.12 P

SERIE 090M

Multi Couplings Systems for quick changing of injection moulding and die cast equipments

Multikupplungensysteme für schnelles Wechseln und Verbinden der Kokillen und Spritzgußformen

Machine Side

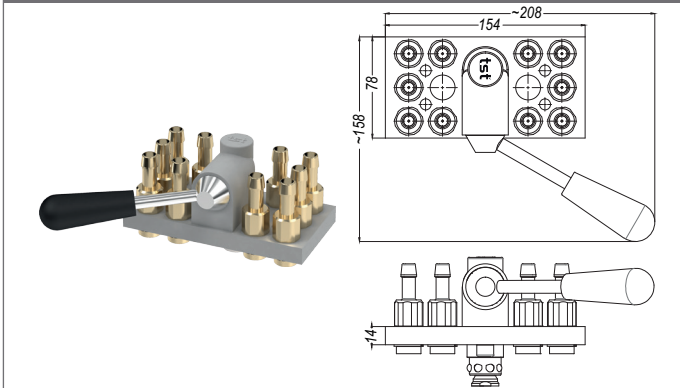

Mould Side

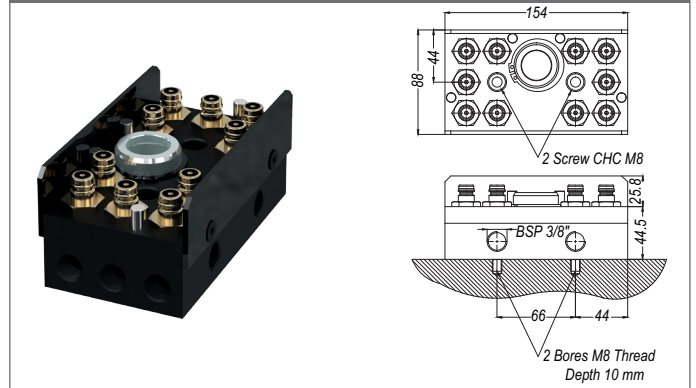

Part No.	Unit	Ø
MM090.10	-	without couplings
MM090.10 HGB 10	10	Hose tail 10 mm
MM090.10 HGB 12	10	Hose tail 12 mm
MM090.10 FGB 10	10	Push-Lock Hose tail 10 mm
MM090.10 FGB 13	10	Push-Lock Hose tail 13 mm
MM090.10 DGB 17	10	BSP female 3/8"
MM090.10 NGB 17	10	NPT female 3/8"

Part No.	Unit	Ø
MK090.10	10	BSP male 3/8" without valve
MK090.10 V	10	BSP male 3/8" with valve

Parking Plate

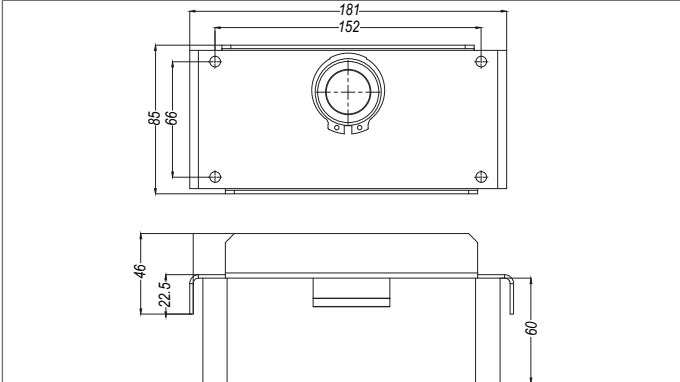

Part No.
MM109.12 P

MULTICOUPLINGS
 MULTIKUPPLUNGEN

4 ↔ 4

SERIE 090M

Multi Couplings Systems for quick changing of injection moulding and die cast equipments

Multikupplungensysteme für schnelles Wechseln und Verbinden der Kokillen und Spritzgußformen

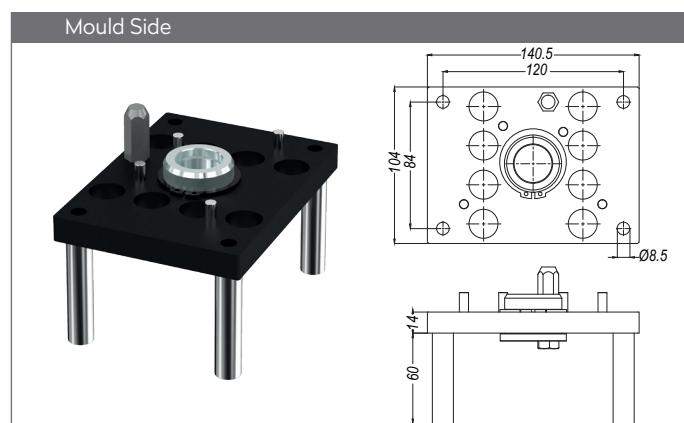
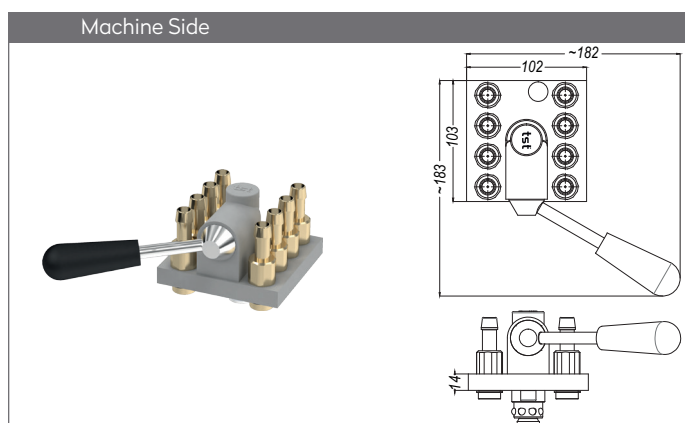

Part No.	Unit	Ø
MM090.08	-	without couplings
MM090.08 HGB 10	8	Hose tail 10 mm
MM090.08 HGB 12	8	Hose tail 12 mm
MM090.08 FGB 10	8	Push-Lock Hose tail 10 mm
MM090.08 FGB 13	8	Push-Lock Hose tail 13 mm
MM090.08 DGB 17	8	BSP female 3/8"
MM090.08 NGB 17	8	NPT female 3/8"

Part No.	Unit	Ø
MK090.08	-	without plugs
MK090.08 DUB 17	8	BSP female 3/8" with valve
MK090.08 NUB 17	8	NPT female 3/8" with valve
MK090.08 DU 17	8	BSP female 3/8" without valve
MK090.08 NU 17	8	NPT female 3/8" without valve

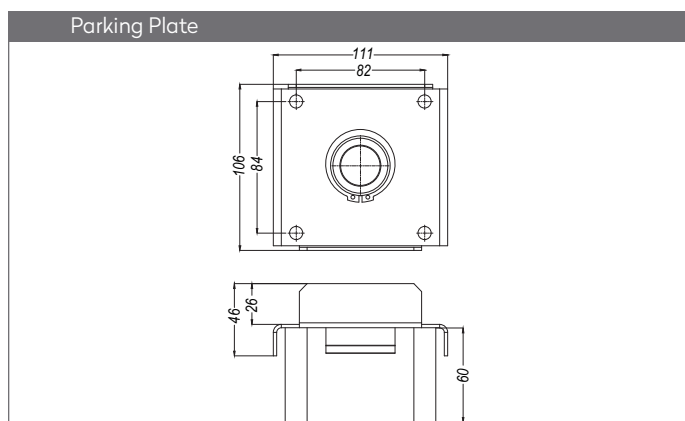

Part No.
MM109.08 P

SERIE 090M

Multi Couplings Systems for quick changing of injection moulding and die cast equipments

Multikupplungensysteme für schnelles Wechseln und Verbinden der Kokillen und Spritzgußformen

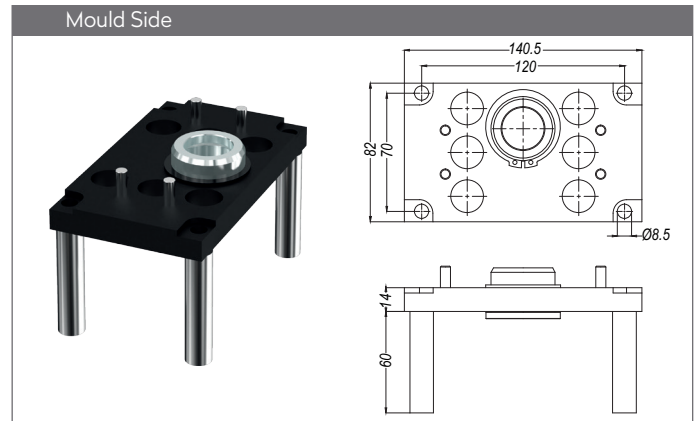
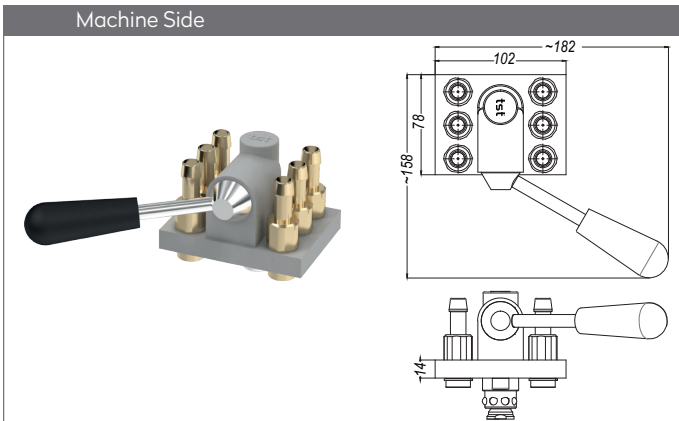

Part No.	Unit	Ø
MM090.06	-	without couplings
MM090.06 HGB 10	6	Hose tail 10 mm
MM090.06 HGB 12	6	Hose tail 12 mm
MM090.06 FGB 10	6	Push-Lock Hose tail 10 mm
MM090.06 FGB 13	6	Push-Lock Hose tail 13 mm
MM090.06 DGB 17	6	BSP female 3/8"
MM090.06 NGB 17	6	NPT female 3/8"

Part No.	Unit	Ø
MK090.06	-	without plugs
MK090.06 DUB 17	6	BSP female 3/8" with valve
MK090.06 NUB 17	6	NPT female 3/8" with valve
MK090.06 DU 17	6	BSP female 3/8" without valve
MK090.06 NU 17	6	NPT female 3/8" without valve

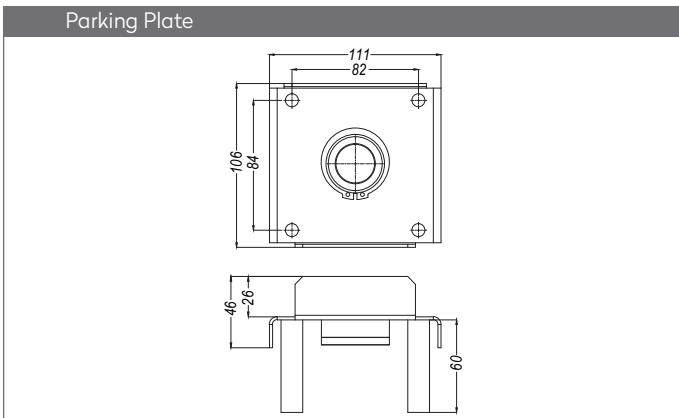

Part No.
MM109.08 P

MULTICOUPLINGS
 MULTIKUPPLUNGEN

SERIE 090M

QUICK COUPLINGS SCHNELLKUPPLUNGEN

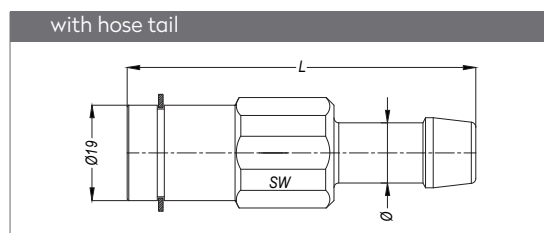

With Valve	Without Valve	SW	Ø	L
MM090 HGB 10	MM090 HGF 10	21	10	69.5
MM090 HGB 12	MM090 HGF 12	21	12	69.5

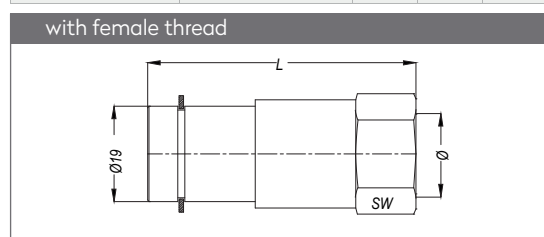

With Valve	Without Valve	SW	Ø	L
MM090 DGB 17	MM090 DGF 17	22	BSP 3/8"	53.5
MM090 NGB 17	MM090 NGF 17	22	NPT 3/8"	53.5

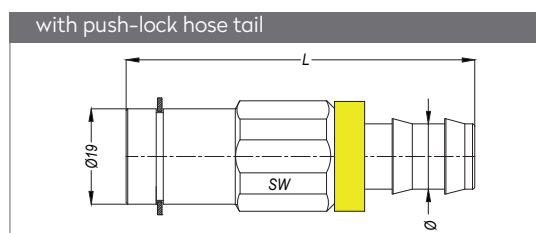

With Valve	Without Valve	SW	Ø	L
MM090 FGB 10	MM090 FGF 10	21	10	65.5
MM090 FGB 13	MM090 FGF 13	21	13	69.5

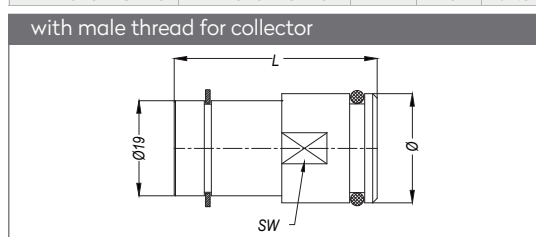

With Valve	Without Valve	SW	Ø	L
MM090 EGB 00	-	21	21.8	40.5

PLUGS STECKNIPPEL

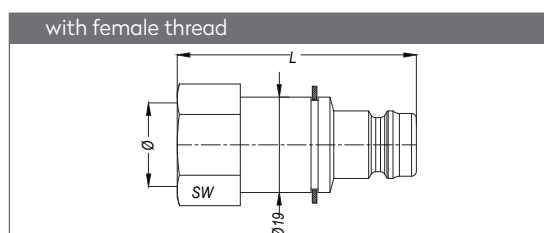

With Valve	Without Valve	SW	Ø	L
MK090 DUB 17	MK090 DUF 17	22	BSP 3/8"	47.7
MK090 NUB 17	MK090 NUF 17	22	NPT 3/8"	47.7

ACCESSORIES ZUBEHÖR

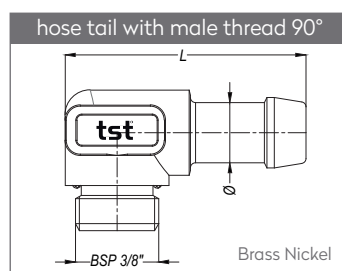

Part No.	Ø
109 EB 17.10	10
109 EB 17.13	13

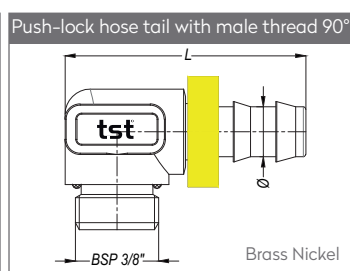

Part No.	Ø
109 EF 17.10	10
109 EF 17.13	13

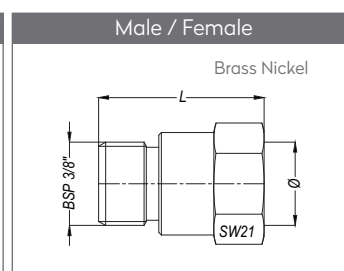

Part No.	Ø
109 EN 17	BSP 3/8"
109 NN 17	NPT 3/8"

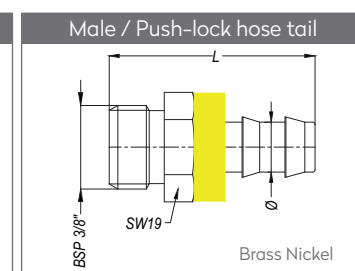

Part No.	Ø
EHF 17-10	10
EHF 17-13	13

Materials

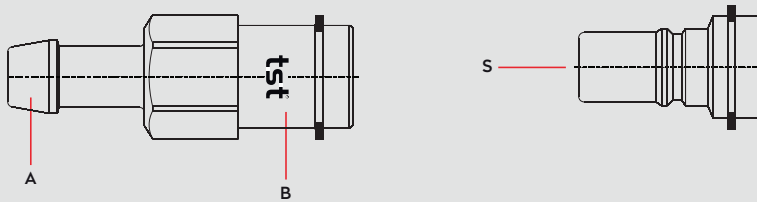

Material Code

- A = Brass
- B = Brass
- S = Brass Nickel Plated



0 - 16 bar



-26°C to + 200°C (FPM)

Shut Off Type

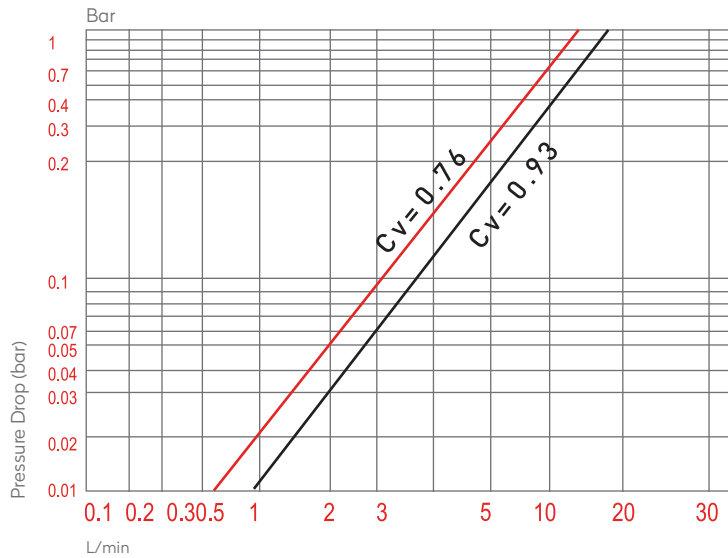
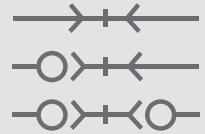

- Double shut-off / Beidseitig absperrend
- (Single shut-off / Einseitig absperrend)

Options

NICKEL



PLUG COUPLING

OV 200 - 00800
OV 200 - 00450
OV 120 - 00900

OV 178 - 00290
OV 178 - 01110

Applications

- Temperature controlling

DN

6 mm

Compatible with

MULTICOUPLINGS

MULTIKUPPLUNGEN

10 ↔ 10

SERIE 106M

Multi Couplings Systems for quick changing of injection moulding and die cast equipments

Multikupplungensysteme für schnelles Wechseln und Verbinden der Kokillen und Spritzgußformen

Machine Side

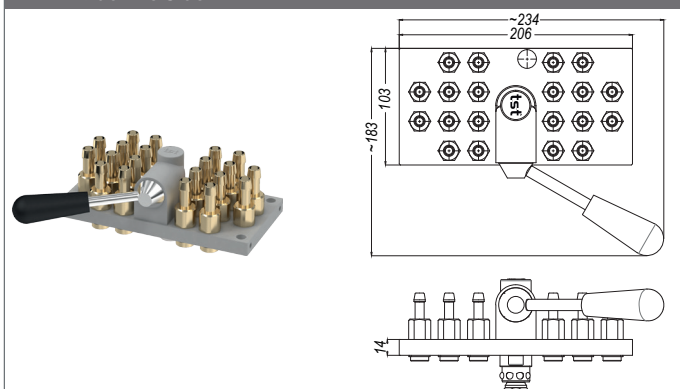

Mould Side

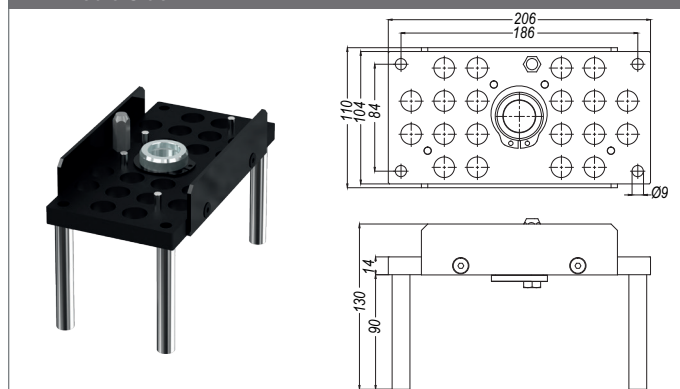

Part No.	Unit	Ø
MM106.20	-	without couplings
MM106.20 HGB 08	20	Hose tail 8 mm
MM106.20 HGB 10	20	Hose tail 10 mm
MM106.20 FGB 08	20	Push-Lock Hose tail 8 mm
MM106.20 FGB 10	20	Push-Lock Hose tail 10 mm
MM109.20 DGB 13	20	BSP female 1/4"
MM109.20 NGB 13	20	NPT female 1/4"

Part No.	Unit	Ø
MK106.20	-	without plugs
MK106.20 DUB 13	20	BSP female 1/4" with valve
MK106.20 NUB 13	20	NPT female 1/4" with valve
MK106.20 DU 13	20	BSP female 1/4" without valve
MK106.20 NU 13	20	NPT female 1/4" without valve

Parking Plate

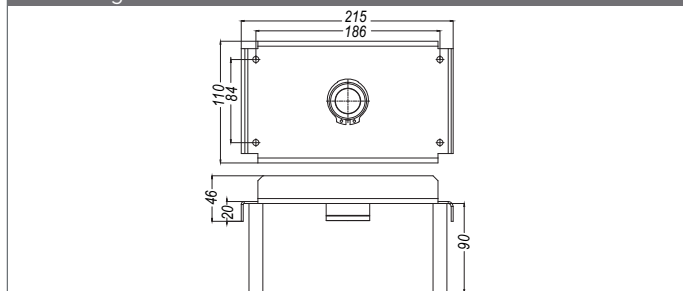

Part No.

MM109.24 P

SERIE 106M

Multi Couplings Systems for quick changing of injection moulding and die cast equipments

Multikupplungensysteme für schnelles Wechseln und Verbinden der Kokillen und Spritzgußformen

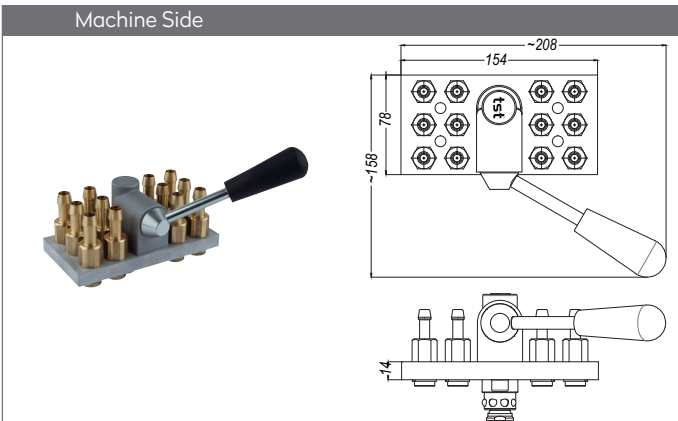

Part No.	Unit	Ø
MM106.12	-	without couplings
MM106.12 HGB 08	12	Hose tail 8 mm
MM106.12 HGB 10	12	Hose tail 10 mm
MM106.12 FGB 08	12	Push-Lock Hose tail 8 mm
MM106.12 FGB 10	12	Push-Lock Hose tail 10 mm
MM106.12 DGB 13	12	BSP female 1/4"
MM106.12 NGB 13	12	NPT female 1/4"

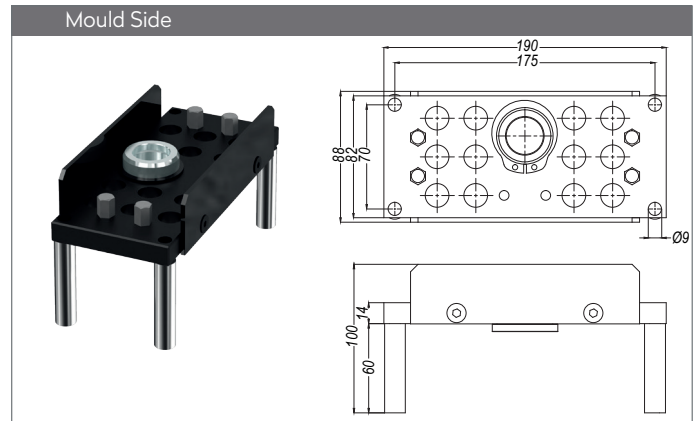

Part No.	Unit	Ø
MK106.12	-	without plugs
MK106.12 DUB 13	12	BSP female 1/4" with valve
MK106.12 NUB 13	12	NPT female 1/4" with valve
MK106.12 DU 13	12	BSP female 1/4" without valve
MK106.12 NU 13	12	NPT female 1/4" without valve

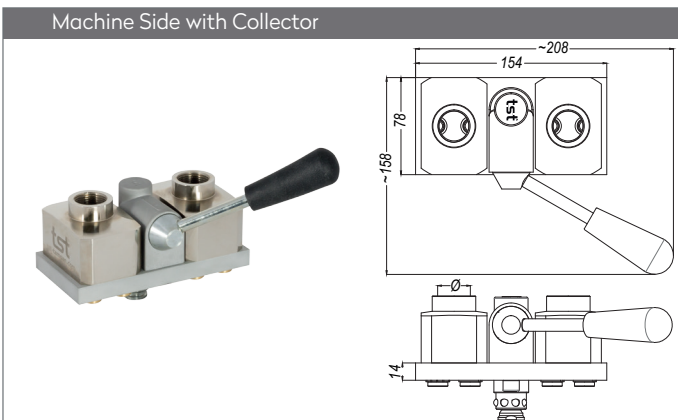

Part No.	Unit	Ø
MM106.12C	12	BSP female 3/4"
MM106.12CN	12	NPT female 3/4"

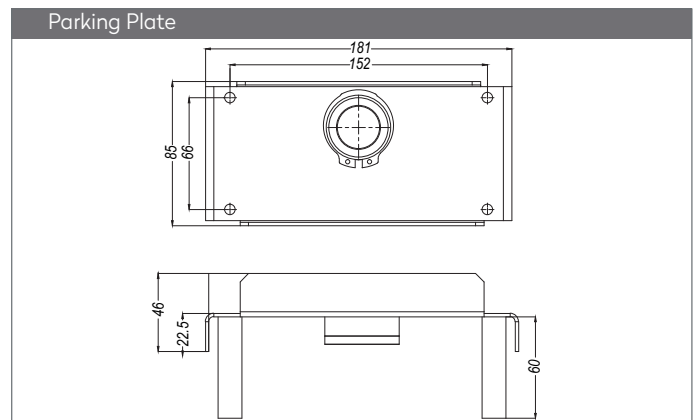

Part No.
MM109.12 P

4 ↔ 4

SERIE 106M

Multi Couplings Systems for quick changing of injection moulding and die cast equipments

Multikupplungensysteme für schnelles Wechseln und Verbinden der Kokillen und Spritzgußformen

Machine Side

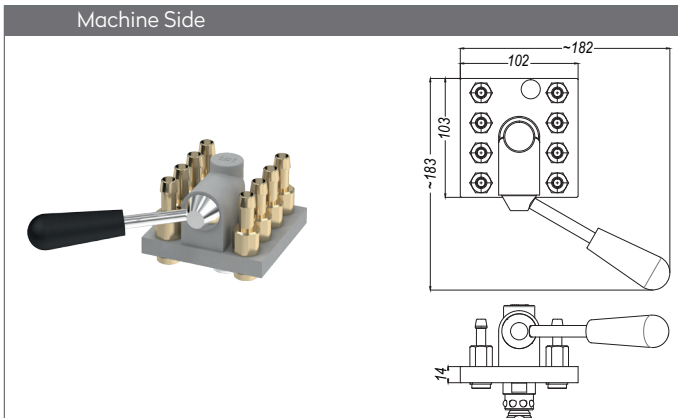

Mould Side

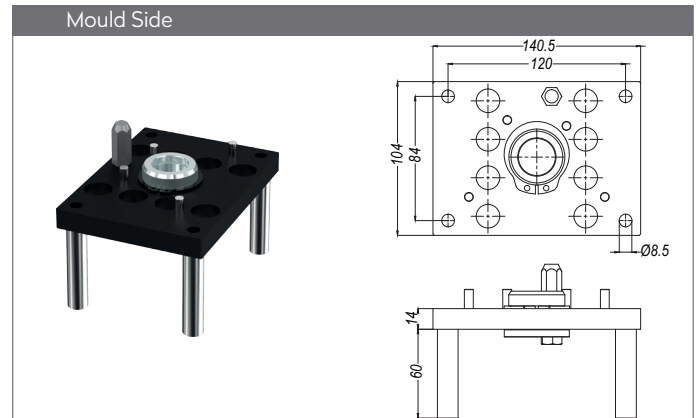

Part No.	Unit	Ø
MM106.08	-	without couplings
MM106.08 HGB 08	8	Hose tail 8 mm
MM106.08 HGB 10	8	Hose tail 10 mm
MM106.08 FGB 08	8	Push-Lock Hose tail 8 mm
MM106.08 FGB 10	8	Push-Lock Hose tail 10 mm
MM106.08 DGB 13	8	BSP female 1/4"
MM106.08 NGB 13	8	NPT female 1/4"

Part No.	Unit	Ø
MK106.08	-	without plugs
MK106.08 DUB 13	8	BSP female 1/4" with valve
MK106.08 NUB 13	8	NPT female 1/4" with valve
MK106.08 DU 13	8	BSP female 1/4" without valve
MK106.08 NU 13	8	NPT female 1/4" without valve

SERIE 106M

Multi Couplings Systems for quick changing of injection moulding and die cast equipments

Multikupplungensysteme für schnelles Wechseln und Verbinden der Kokillen und Spritzgußformen

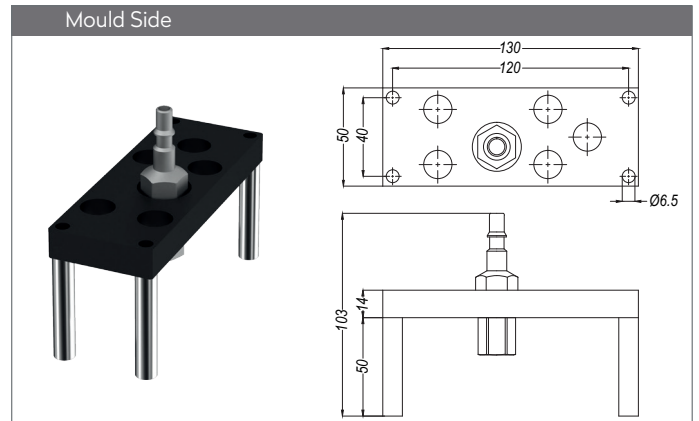
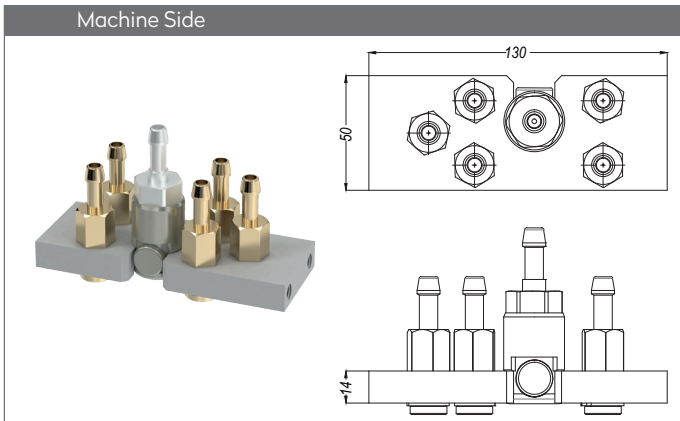

Part No.	Unit	Ø
MM106.06	-	without couplings
MM106.06 HGB 08	6	Hose tail 8 mm
MM106.06 HGB 10	6	Hose tail 10 mm
MM106.06 FGB 08	6	Push-Lock Hose tail 8 mm
MM106.06 FGB 10	6	Push-Lock Hose tail 10 mm
MM109.06 DGB 13	6	BSP female 1/4"
MM109.06 NGB 13	6	NPT female 1/4"

Part No.	Unit	Ø
MK106.06	-	without plugs
MK106.06 DUB 13	6	BSP female 1/4" with valve
MK106.06 NUB 13	6	NPT female 1/4" with valve
MK106.06 DU 13	6	BSP female 1/4" without valve
MK106.06 NU 13	6	NPT female 1/4" without valve

MULTICOUPLINGS
 MULTIKUPPLUNGEN

SERIE 106M

QUICK COUPLINGS SCHNELLKUPPLUNGEN

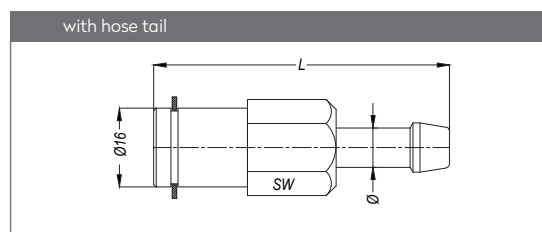

With Valve	Without Valve	SW	Ø	L
MM106 HGB 08	MM106 HGF 08	17	8	60
MM106 HGB 10	MM106 HGF 10	17	10	60

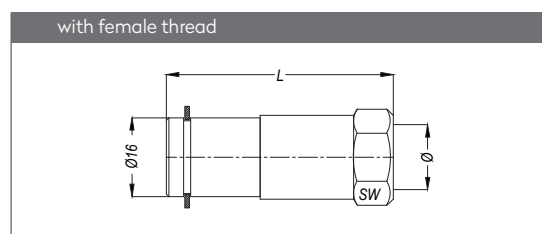

With Valve	Without Valve	SW	Ø	L
MM106 DGB 13	MM106 DGF 13	17	BSP 1/4"	46
MM106 NGB 13	MM106 NGF 13	17	NPT 1/4"	46

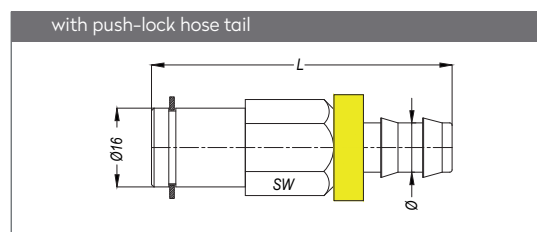

With Valve	Without Valve	SW	Ø	L
MM106 FGB 08	MM106 FGF 08	17	8	61
MM106 FGB 10	MM106 FGF 10	17	10	61

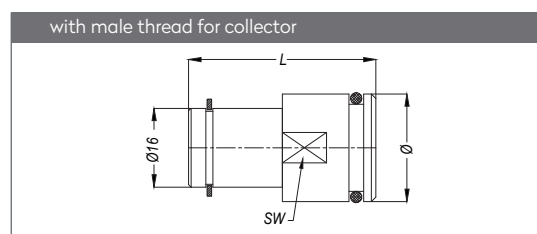

With Valve	Without Valve	SW	Ø	L
MM106 EGB 00	-	21	21.8	38

PLUGS STECKNIPPEL

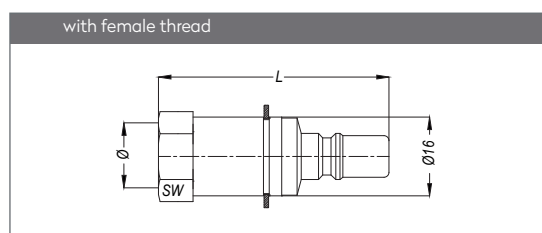

With Valve	Without Valve	SW	Ø	L
MK106 DUB 13	MK106 DU 13	17	BSP 1/4"	46.8
MK106 NUB 13	MK106 NU 13	17	NPT 1/4"	46.8

ACCESSORIES ZUBEHÖR

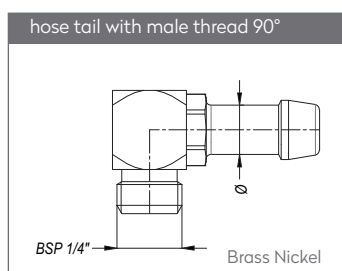

Part No.	Ø
106 EB 13.08	8
106 EB 13.10	10

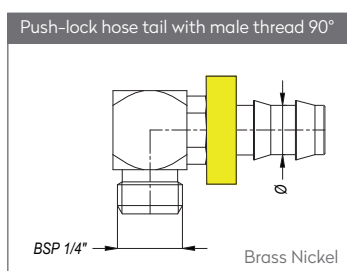

Part No.	Ø
106 EF 13.08	8
106 EF 13.10	10

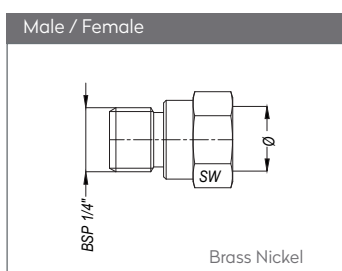

Part No.	Ø
106 EN 13	BSP 1/4"
106 NN 13	NPT 1/4"

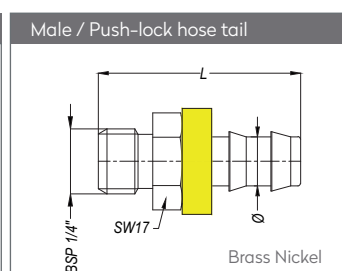

Part No.	Ø
EHF 13-10	10
EHF 13-13	13

Materials

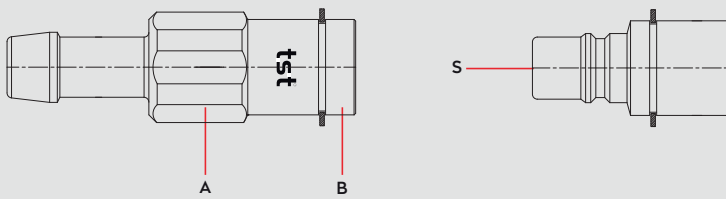

Material Code

- A = Brass
- B = Brass
- S = Brass Nickel Plated



0 - 16 bar



-26°C to + 200°C (FPM)

Shut Off Type

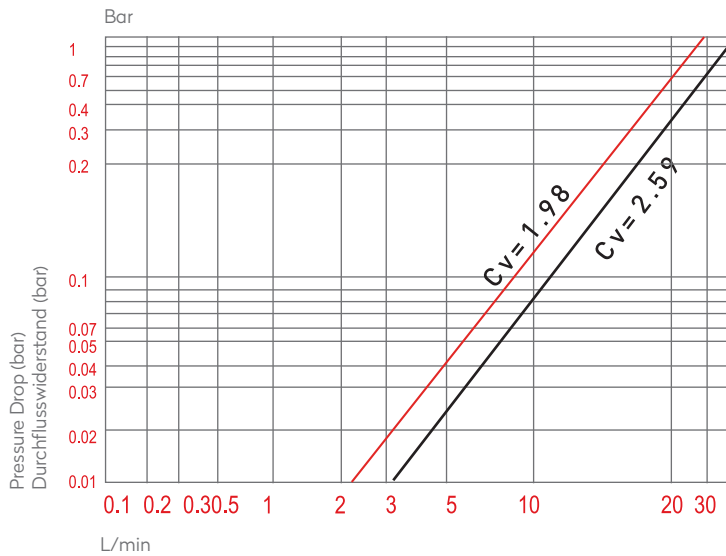
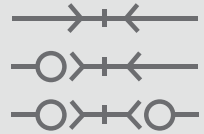

- Double shut-off / Beidseitig absperrend
- (Single shut-off / Einseitig absperrend)

Options

NICKEL		COLOURED PLATE
HT	AISI303 Stainless Steel	EPDM

	COUPLING	OV 262 - 01235 OV 100 - 01300 OV 200 - 00800
	PLUG	OV 200 - 00600

Applications

- Temperature controlling

DN	9 mm
----	------

Compatible with

12 ⇄ 12

SERIE 109M

Multi Couplings Systems for quick changing of injection moulding and die cast equipments

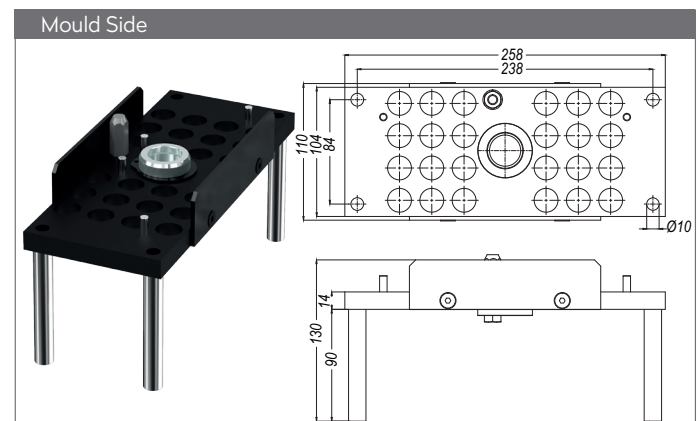
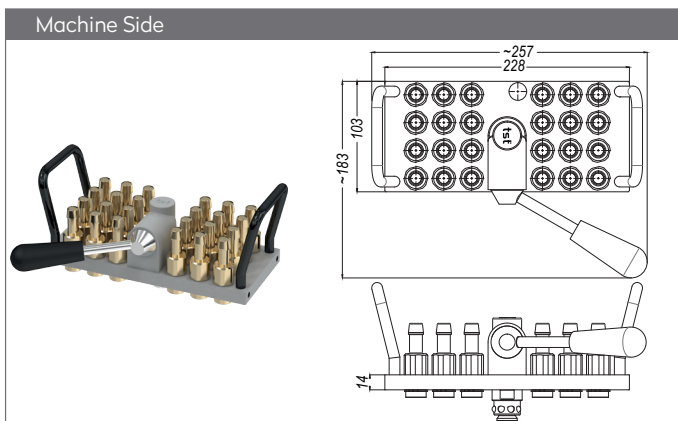
Multikupplungensysteme für schnelles Wechseln und Verbinden der Kokillen und Spritzgußformen

Part No.	Unit	Ø
MM109.24	-	without couplings
MM109.24 HGB 10	24	Hose tail 10 mm
MM109.24 HGB 12	24	Hose tail 12 mm
MM109.24 FGB 10	24	Push-Lock Hose tail 10 mm
MM109.24 FGB 13	24	Push-Lock Hose tail 13 mm
MM109.24 DGB 17	24	BSP female 3/8"
MM109.24 NGB 17	24	NPT female 3/8"

Part No.	Unit	Ø
MK109.24	-	without plugs
MK109.24 DUB 17	24	BSP female 3/8" with valve
MK109.24 NUB 17	24	NPT female 3/8" with valve
MK109.24 DU 17	24	BSP female 3/8" without valve
MK109.24 NU 17	24	NPT female 3/8" without valve

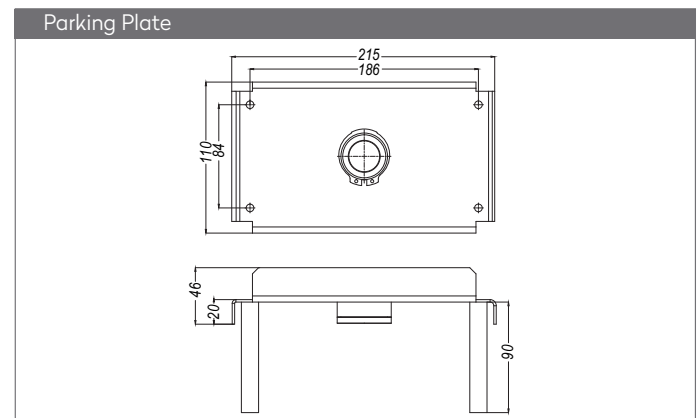
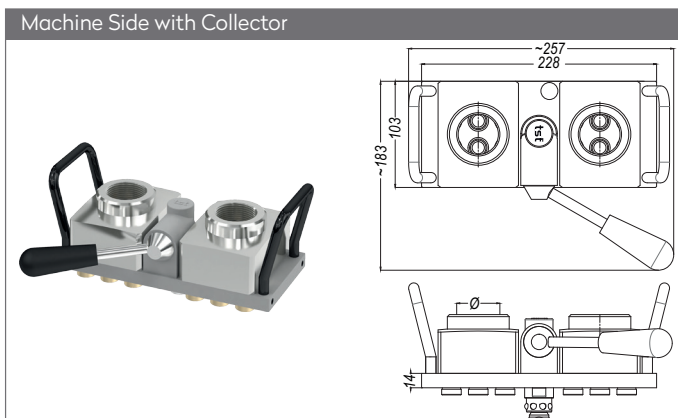

Part No.	Unit	Ø
MM109.24C	24	BSP female 1 1/4"
MM109.24CN	24	NPT female 1 1/4"

Part No.
MM109.24 P

SERIE 109M $10 \leftrightarrow 10$

Multi Couplings Systems for quick changing of injection moulding and die cast equipments

Multikupplungensysteme für schnelles Wechseln und Verbinden der Kokillen und Spritzgußformen

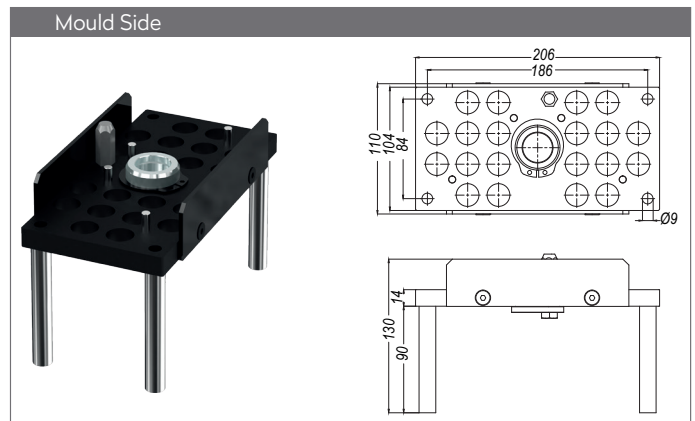
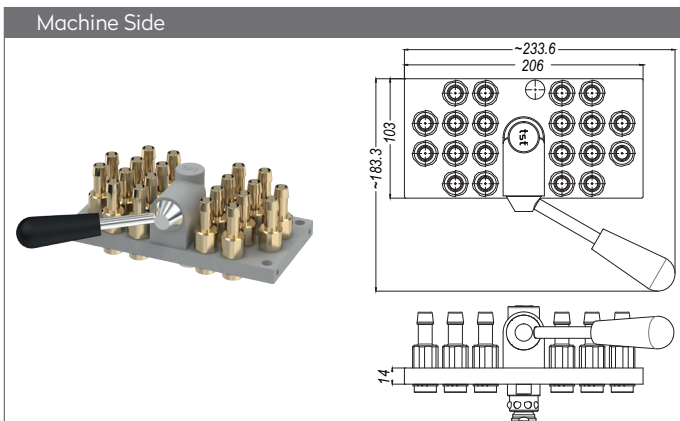

Part No.	Unit	Ø
MM109.20	-	without couplings
MM109.20 HGB 10	20	Hose tail 10 mm
MM109.20 HGB 12	20	Hose tail 12 mm
MM109.20 FGB 10	20	Push-Lock Hose tail 10 mm
MM109.20 FGB 13	20	Push-Lock Hose tail 13 mm
MM109.20 DGB 17	20	BSP female 3/8"
MM109.20 NGB 17	20	NPT female 3/8"

Part No.	Unit	Ø
MK109.20	-	without plugs
MK109.20 DUB 17	20	BSP female 3/8" with valve
MK109.20 NUB 17	20	NPT female 3/8" with valve
MK109.20 DU 17	20	BSP female 3/8" without valve
MK109.20 NU 17	20	NPT female 3/8" without valve

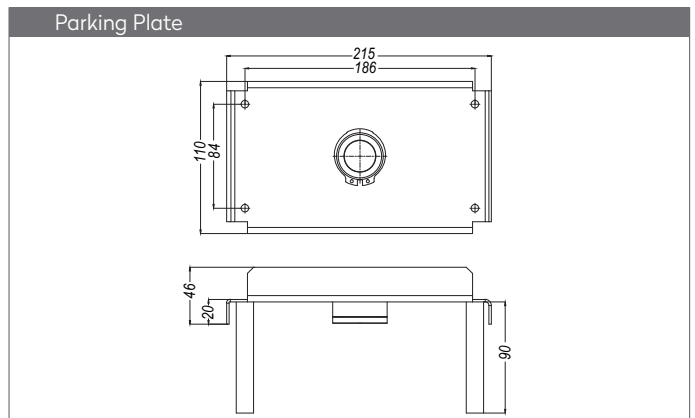
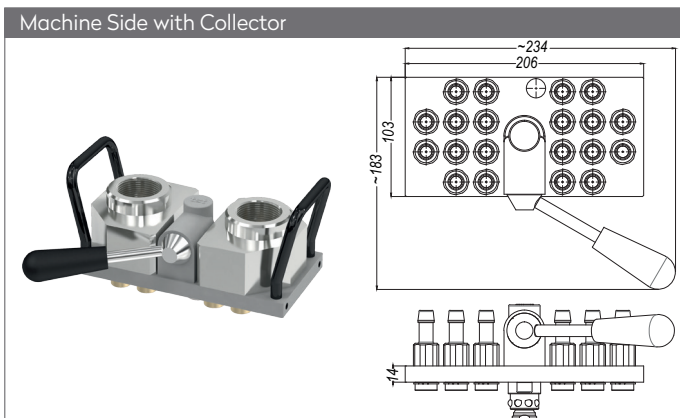

Part No.	Unit	Ø
MM109.20C	20	BSP female 1 1/4"
MM109.20CN	20	NPT female 1 1/4"

Part No.
MM109.24 P

MULTICOUPLINGS

MULTIKUPPLUNGEN

8 ↔ 8

SERIE 109M

Multi Couplings Systems for quick changing of injection moulding and die cast equipments

Multikupplungensysteme für schnelles Wechseln und Verbinden der Kokillen und Spritzgußformen

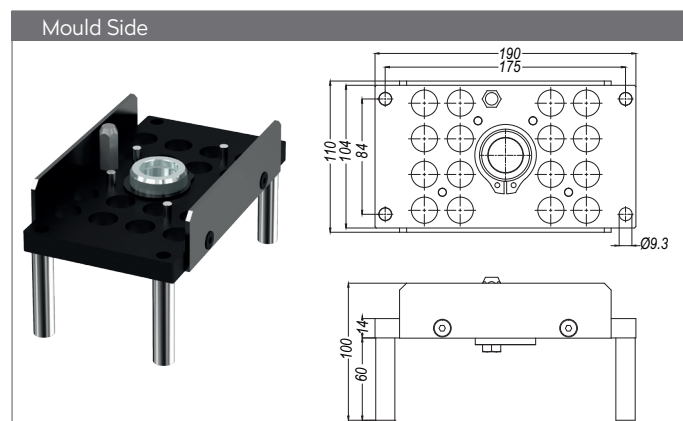
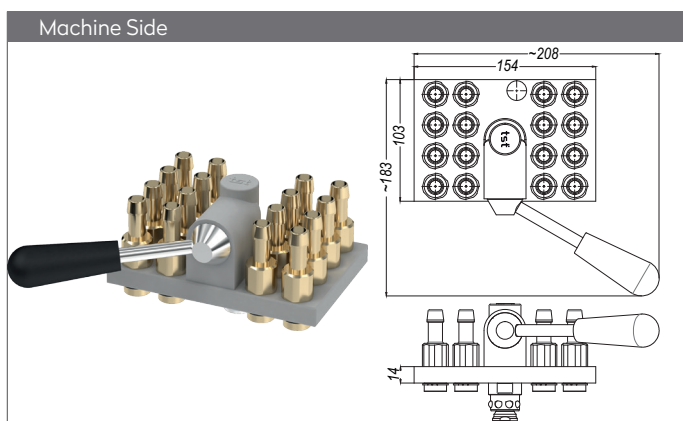

Part No.	Unit	Ø
MM109.16	-	without couplings
MM109.16 HGB 10	16	Hose tail 10 mm
MM109.16 HGB 12	16	Hose tail 12 mm
MM109.16 FGB 10	16	Push-Lock Hose tail 10 mm
MM109.16 FGB 13	16	Push-Lock Hose tail 13 mm
MM109.16 DGB 17	16	BSP female 3/8"
MM109.16 NGB 17	16	NPT female 3/8"

Part No.	Unit	Ø
MK109.16	-	without plugs
MK109.16 DUB 17	16	BSP female 3/8" with valve
MK109.16 NUB 17	16	NPT female 3/8" with valve
MK109.16 DU 17	16	BSP female 3/8" without valve
MK109.16 NU 17	16	NPT female 3/8" without valve

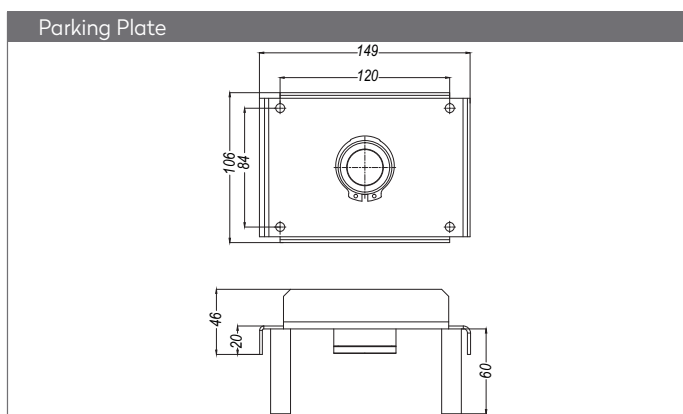

Part No.
MM109.16 P

MULTICOUPLINGS
MULTIKUPPLUNGEN

6 ↔ 6

SERIE 109M

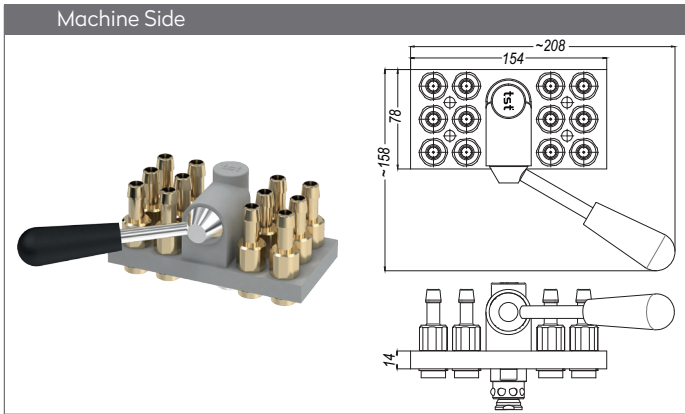

Part No.	Unit	Ø
MM109.12	-	without couplings
MM109.12 HGB 10	12	Hose tail 10 mm
MM109.12 HGB 12	12	Hose tail 12 mm
MM109.12 FGB 10	12	Push-Lock Hose tail 10 mm
MM109.12 FGB 13	12	Push-Lock Hose tail 13 mm
MM109.12 DGB 17	12	BSP female 3/8"
MM109.12 NGB 17	12	NPT female 3/8"

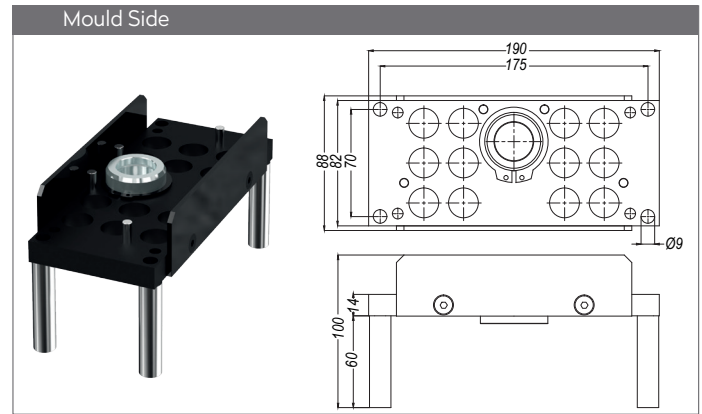

Part No.	Unit	Ø
MK109.12	-	without plugs
MK109.12 DUB 17	12	BSP female 3/8" with valve
MK109.12 NUB 17	12	NPT female 3/8" with valve
MK109.12 DU 17	12	BSP female 3/8" without valve
MK109.12 NU 17	12	NPT female 3/8" without valve

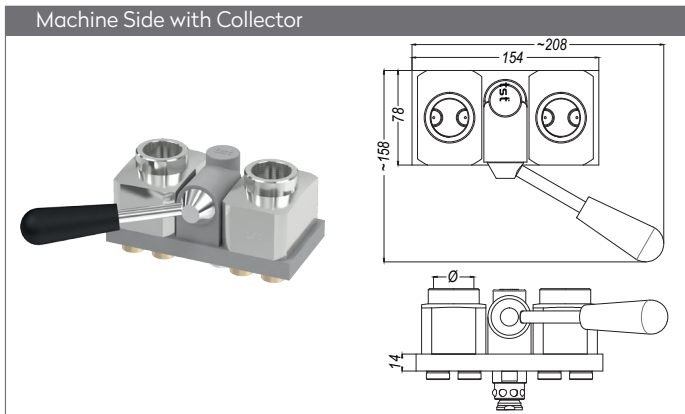

Part No.	Unit	Ø
MM109.12C	12	BSP female 1"
MM109.12CN	12	NPT female 1"

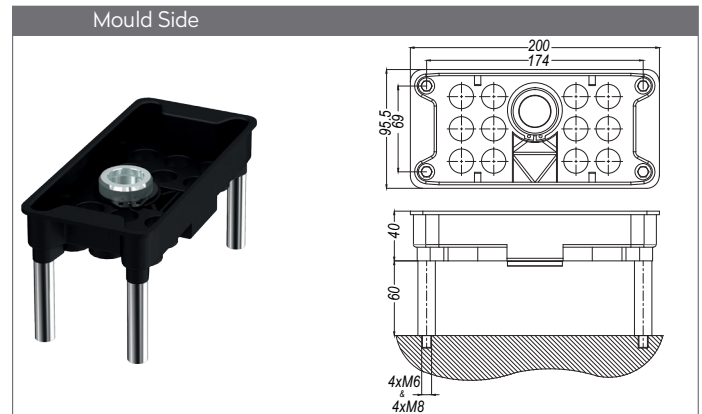

Part No.	Unit	Ø
MK109.12K	-	without plugs
MK109.12K DUB 17	12	BSP female 3/8" with valve
MK109.12K NUB 17	12	NPT female 3/8" with valve
MK109.12K DU 17	12	BSP female 3/8" without valve
MK109.12K NU 17	12	NPT female 3/8" without valve

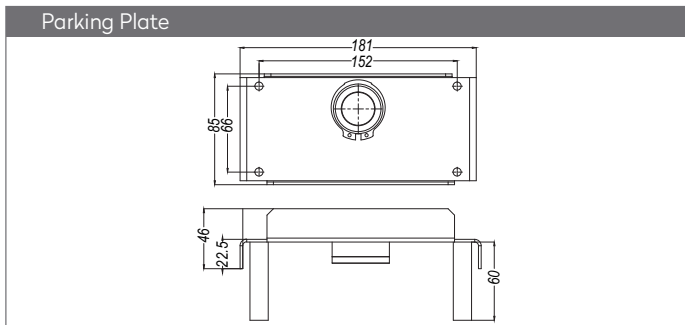

Part No.
MM109.12 P

MULTICOUPLINGS

MULTIKUPPLUNGEN

5 ↔ 5

SERIE 109M

Multi Couplings Systems for quick changing of injection moulding and die cast equipments

Multikupplungensysteme für schnelles Wechseln und Verbinden der Kokillen und Spritzgußformen

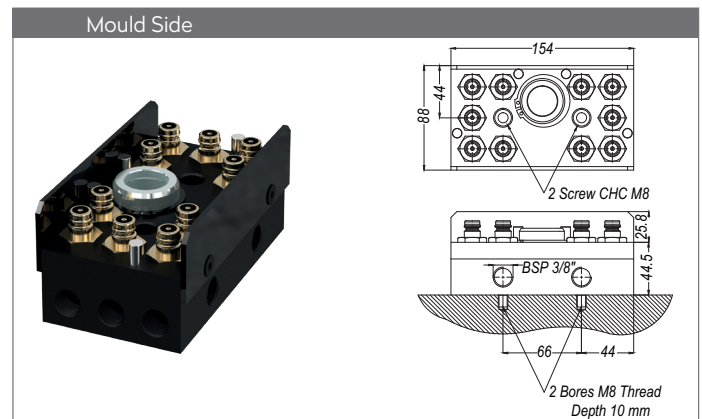
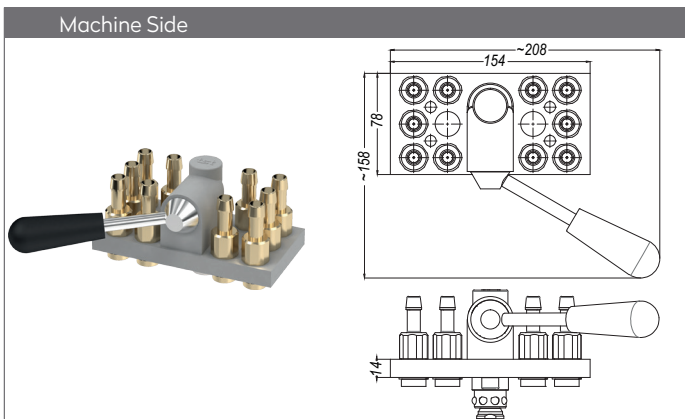

Part No.	Unit	Ø
MM109.12	-	without couplings
MM109.10 HGB 10	10	Hose tail 10 mm
MM109.10 HGB 12	10	Hose tail 12 mm
MM109.10 FGB 10	10	Push-Lock Hose tail 10 mm
MM109.10 FGB 13	10	Push-Lock Hose tail 13 mm
MM109.10 DGB 17	10	BSP female 3/8"
MM109.10 NGB 17	10	NPT female 3/8"

Part No.	Unit	Ø
MK109.10	10	BSP male 1/2" without valve
MK109.10 V	10	BSP male 1/2" with valve

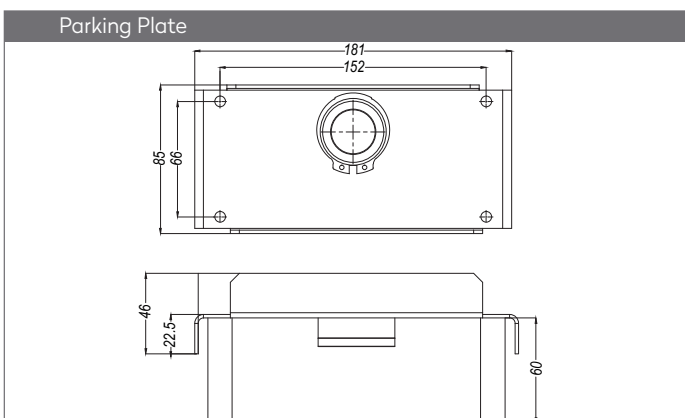

Part No.
MM109.12 P



SERIE 109M

Multi Couplings Systems for quick changing of injection moulding and die cast equipments

Multikupplungensysteme für schnelles Wechseln und Verbinden der Kokillen und Spritzgußformen

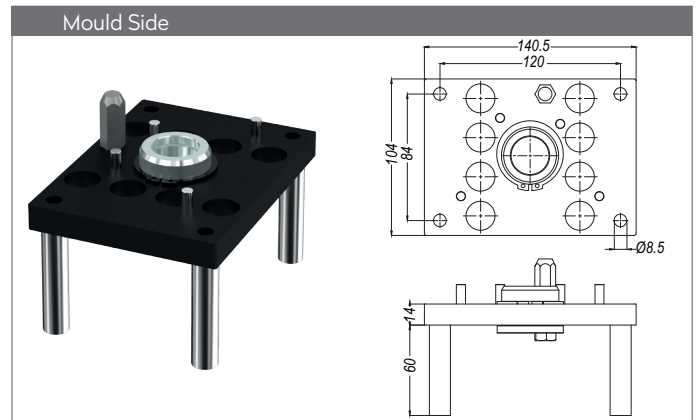
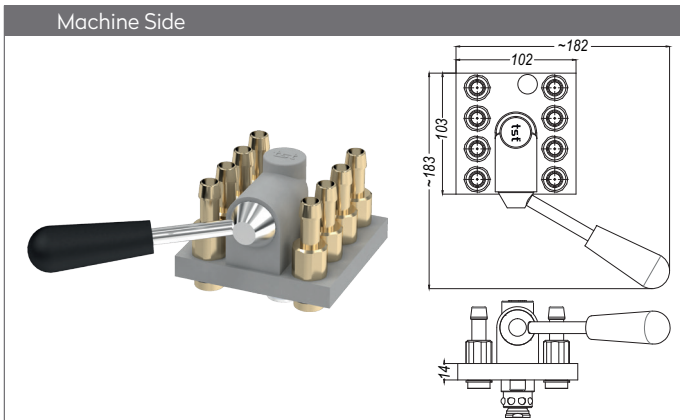

Part No.	Unit	Ø
MM109.08	-	without couplings
MM109.08 HGB 10	8	Hose tail 10 mm
MM109.08 HGB 12	8	Hose tail 12 mm
MM109.08 FGB 10	8	Push-Lock Hose tail 10 mm
MM109.08 FGB 13	8	Push-Lock Hose tail 13 mm
MM109.08 DGB 17	8	BSP female 3/8"
MM109.08 NGB 17	8	NPT female 3/8"

Part No.	Unit	Ø
MK109.08	-	without plugs
MK109.08 DUB 17	8	BSP female 3/8" with valve
MK109.08 NUB 17	8	NPT female 3/8" with valve
MK109.08 DU 17	8	BSP female 3/8" without valve
MK109.08 NU 17	8	NPT female 3/8" without valve

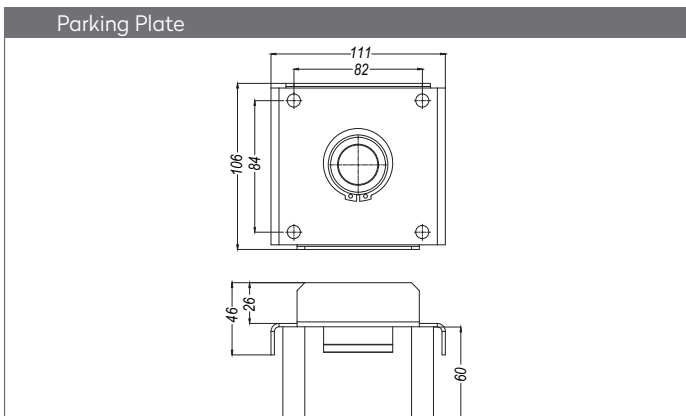

Part No.
MM109.08 P

MULTICOUPLINGS
 MULTIKUPPLUNGEN

3 ↔ 3

SERIE 109M

Multi Couplings Systems for quick changing of injection moulding and die cast equipments

Multikupplungensysteme für schnelles Wechseln und Verbinden der Kokillen und Spritzgußformen

Machine Side

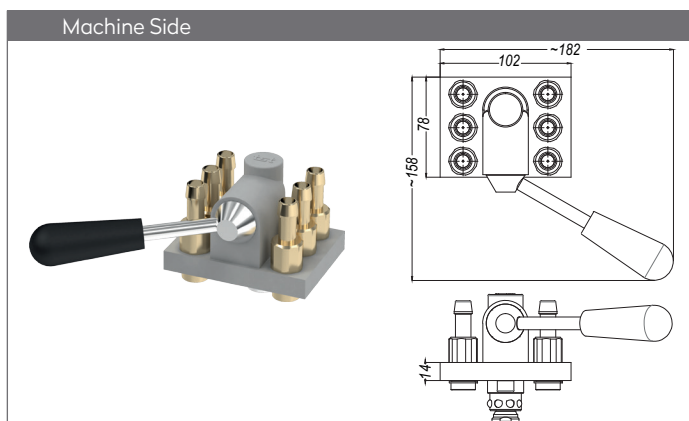

Mould Side

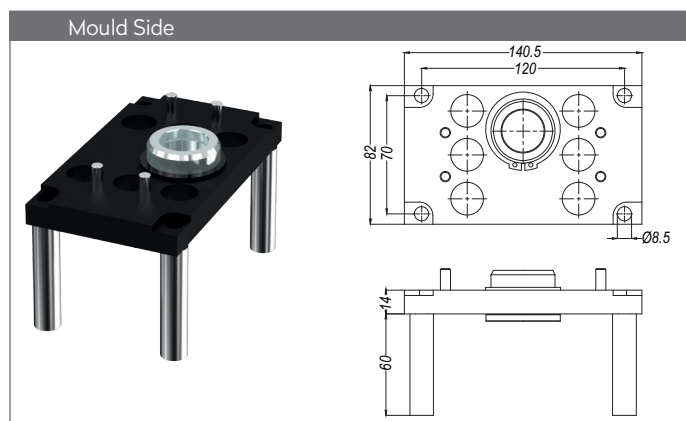

Part No.	Unit	Ø
MM109.06	-	without couplings
MM109.06 HGB 10	6	Hose tail 10 mm
MM109.06 HGB 12	6	Hose tail 12 mm
MM109.06 FGB 10	6	Push-Lock Hose tail 10 mm
MM109.06 FGB 13	6	Push-Lock Hose tail 13 mm
MM109.06 DGB 17	6	BSP female 3/8"
MM109.06 NGB 17	6	NPT female 3/8"

Part No.	Unit	Ø
MK109.06	-	without plugs
MK109.06 DUB 17	6	BSP female 3/8" with valve
MK109.06 NUB 17	6	NPT female 3/8" with valve
MK109.06 DU 17	6	BSP female 3/8" without valve
MK109.06 NU 17	6	NPT female 3/8" without valve

Parking Plate

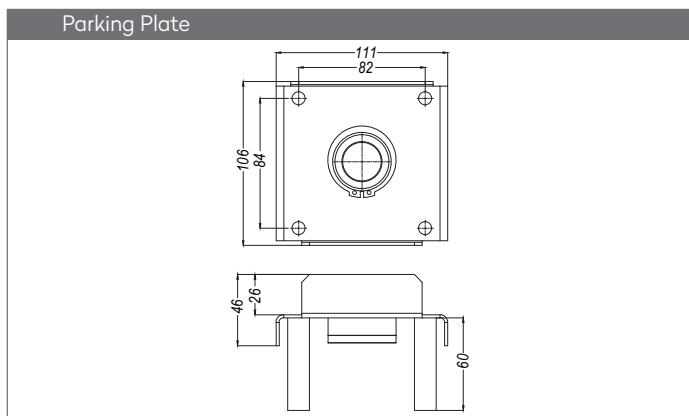

Part No.

MM109.12 P

MULTICOUPLINGS
MULTIKUPPLUNGEN

SERIE 109M

QUICK COUPLINGS SCHNELLKUPPLUNGEN

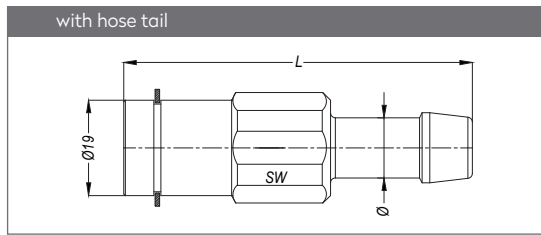

With Valve	Without Valve	SW	Ø	L
MM109 HGB 10	MM109 HGF 10	21	10	69
MM109 HGB 12	MM109 HGF 12	21	12	69

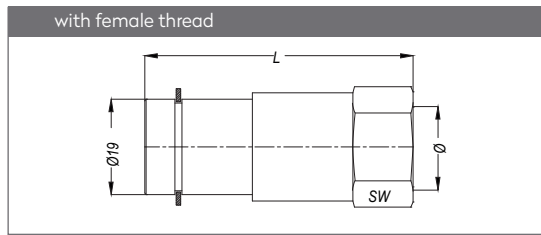

With Valve	Without Valve	SW	Ø	L
MM109 DGB 17	MM109 DGF 17	22	BSP 3/8"	53
MM109 NGB 17	MM109 NGF 17	22	NPT 3/8"	53

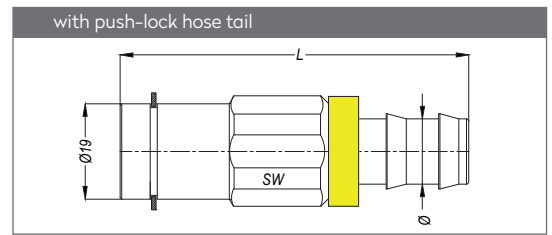

With Valve	Without Valve	SW	Ø	L
MM109 FGB 10	MM109 FGF 10	21	10	65
MM109 FGB 13	MM109 FGF 13	21	13	69

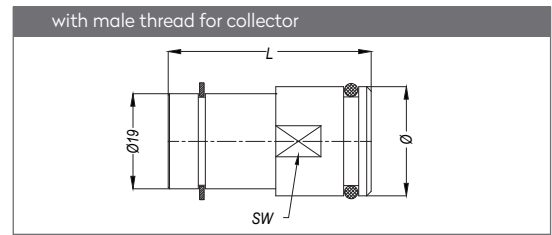

With Valve	Without Valve	SW	Ø	L
MM109 EGB 00	-	21	21.8	40.3

PLUGS STECKNIPPEL

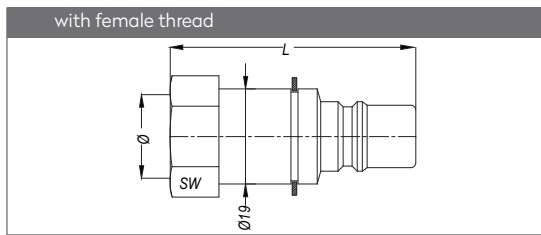

With Valve	Without Valve	SW	Ø	L
MK109 DUB 17	MK109 DUF 17	21	BSP 3/8"	49
MK109 NUB 17	MK109 NUF 17	21	NPT 3/8"	49

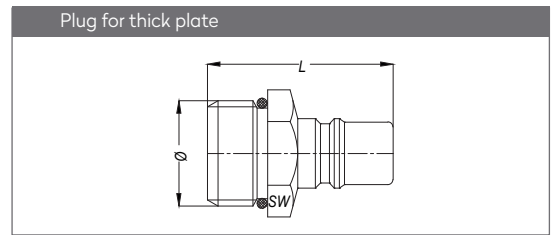

With Valve	Without Valve	SW	Ø	L
101.09 OUB 21	101.09 EUP 21	22	BSP 1/2"	37

ACCESSORIES ZUBEHÖR

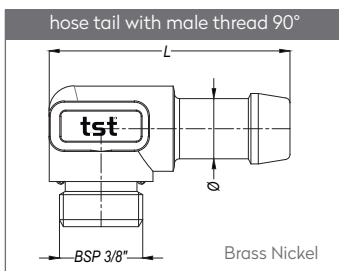

Part No.	Ø
109 EB 17.10	10
109 EB 17.13	13

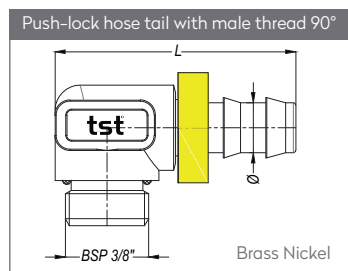

Part No.	Ø
109 EF 17.10	10
109 EF 17.13	13

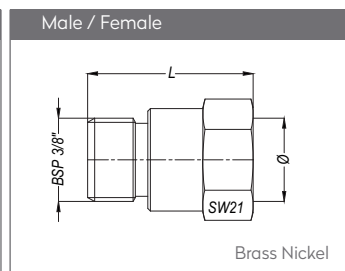

Part No.	Ø
109 EN 17	BSP 3/8"
109 NN 17	NPT 3/8"

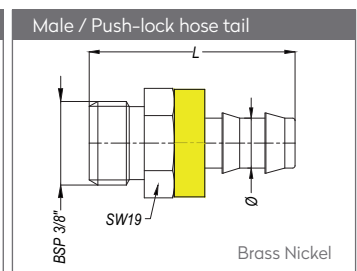

Part No.	Ø
EHF 17-10	10
EHF 17-13	13

DN12

MULTICOUPLINGS
MULTIKUPPLUNGEN

SERIE 112M

Materials

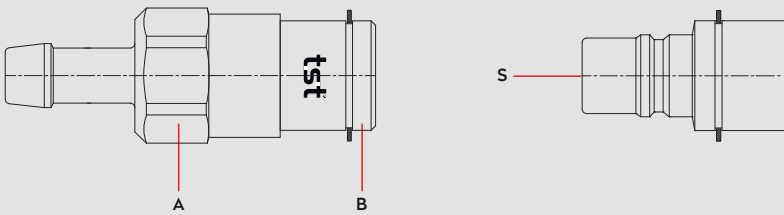

Material Code

A = Brass

B = Brass

S = Brass Nickel Plated



0 - 16 bar



-26°C to + 200°C (FPM)

Shut Off Type

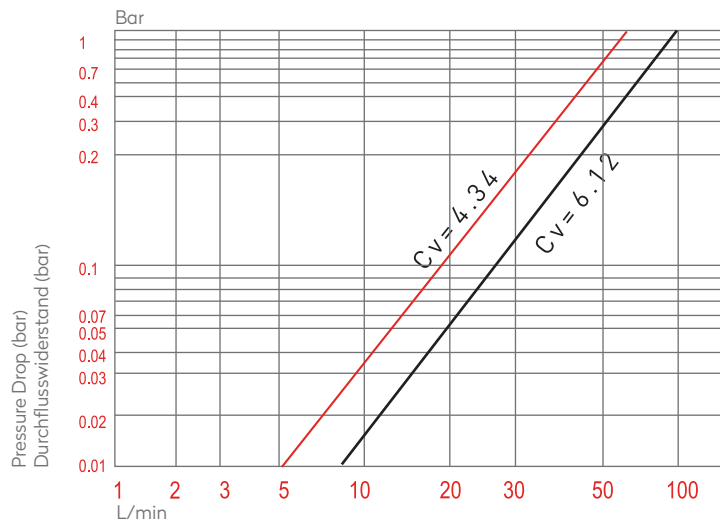
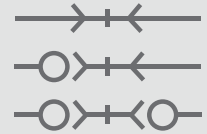

— Double shut-off / Beidseitig absperrend

— (Single shut-off / Einseitig absperrend)

Options

HT

NICKEL

EPDM



COUPLING
PLUG

OV 280 - 01600
OV 157 - 01600
OV 262 - 01075

OV 205 - 00870

Applications

- Temperature controlling

DN

12 mm

Compatible with

SERIE 112M

Multi Couplings Systems for quick changing of injection moulding and die cast equipments

Multikupplungensysteme für schnelles Wechseln und Verbinden der Kokillen und Spritzgußformen

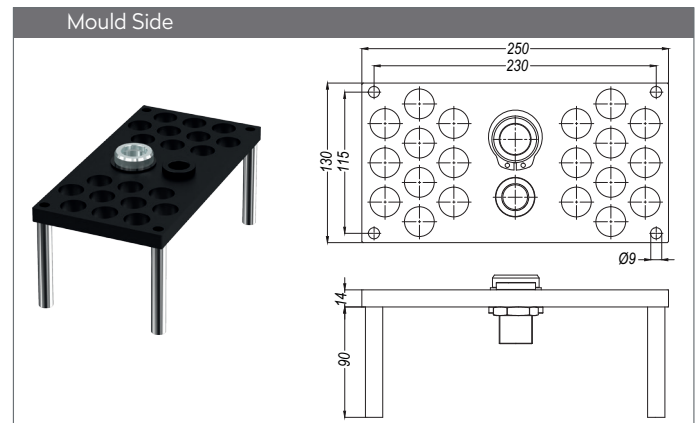
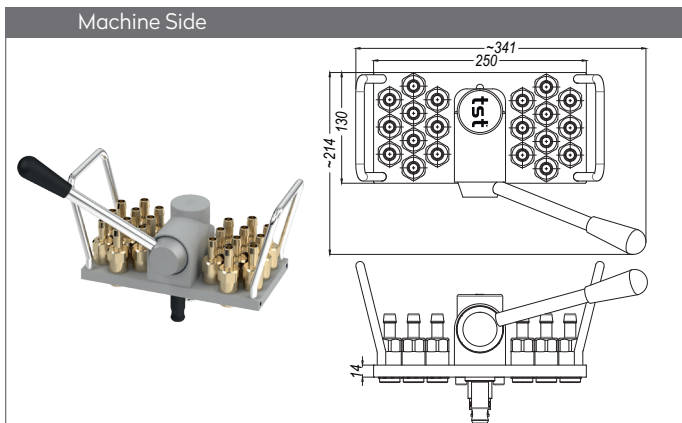

Part No.	Unit	Ø
MM112.20	-	without couplings
MM112.20 HGB 13	20	Hose tail 13 mm
MM112.20 HGB 16	20	Hose tail 16 mm
MM112.20 FGB 13	20	Push-Lock Hose tail 13 mm
MM112.20 FGB 16	20	Push-Lock Hose tail 16 mm
MM112.20 DGB 21	20	BSP female 1/2"
MM112.20 NGB 21	20	NPT female 1/2"

Part No.	Unit	Ø
MK112.20	-	without plugs
MK112.20 DUB 21	20	BSP female 1/2" with valve
MK112.20 NUB 21	20	NPT female 1/2" with valve
MK112.20 DU 21	20	BSP female 1/2" without valve
MK112.20 NU 21	20	NPT female 1/2" without valve

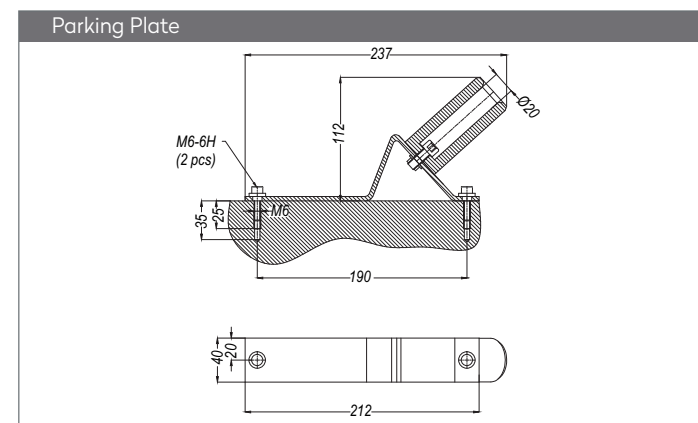
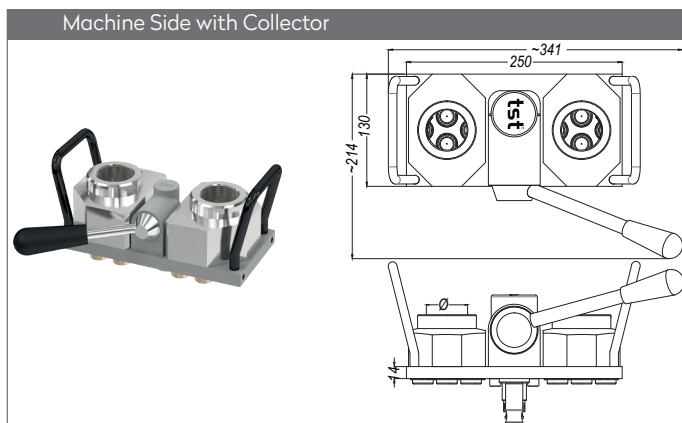

Part No.	Unit	Ø
MM112.20C	20	BSP female 1 1/2"
MM112.20CN	20	NPT female 1 1/2"

Part No.
MM108.06 P

9 ↔ 9

SERIE 112M

Multi Couplings Systems for quick changing of injection moulding and die cast equipments

Multikupplungensysteme für schnelles Wechseln und Verbinden der Kokillen und Spritzgußformen

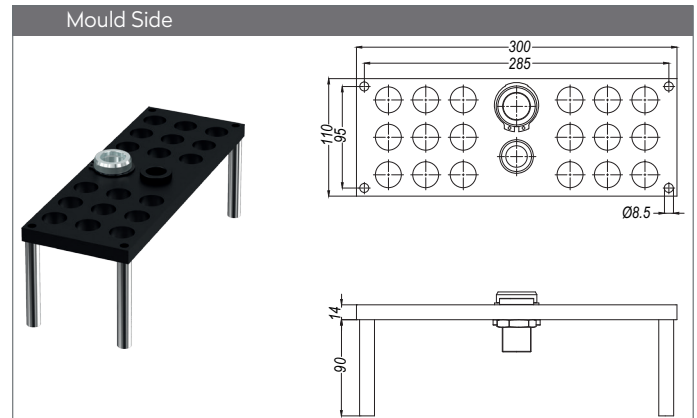
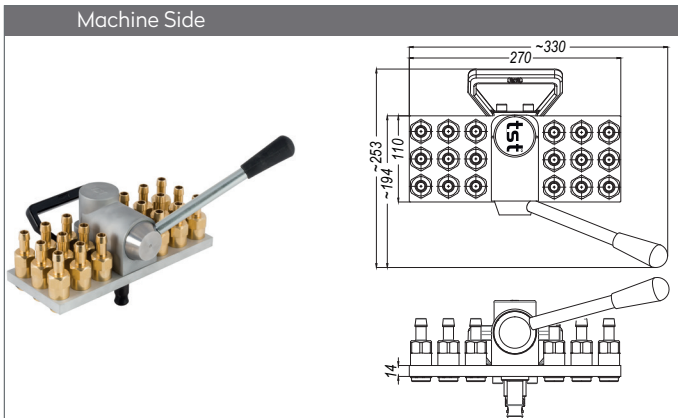

Part No.	Unit	Ø
MM112.18	-	without couplings
MM112.18 HGB 13	18	Hose tail 13 mm
MM112.18 HGB 16	18	Hose tail 16 mm
MM112.18 FGB 13	18	Push-Lock Hose tail 13 mm
MM112.18 FGB 16	18	Push-Lock Hose tail 16 mm
MM112.18 DGB 21	18	BSP female 1/2"
MM112.18 NGB 21	18	NPT female 1/2"

Part No.	Unit	Ø
MK112.18	-	without plugs
MK112.18 DUB 21	18	BSP female 1/2" with valve
MK112.18 NUB 21	18	NPT female 1/2" with valve
MK112.18 DU 21	18	BSP female 1/2" without valve
MK112.18 NU 21	18	NPT female 1/2" without valve

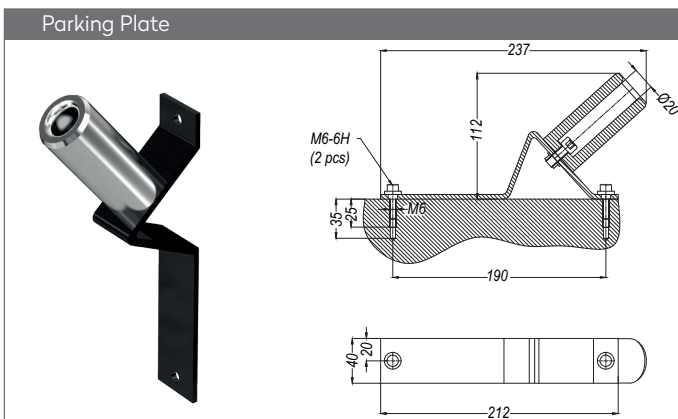

Part No.
MM108.06 P

SERIE 112M

Multi Couplings Systems for quick changing of injection moulding and die cast equipments

Multikupplungensysteme für schnelles Wechseln und Verbinden der Kokillen und Spritzgußformen

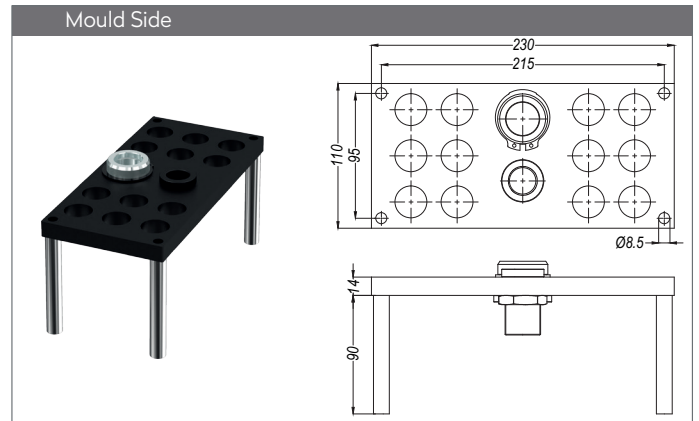
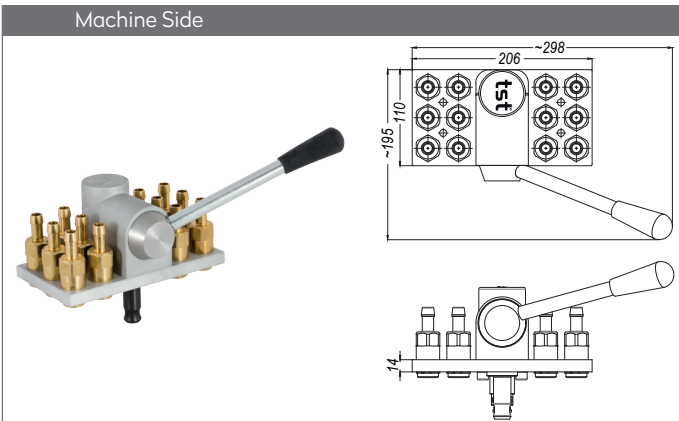

Part No.	Unit	Ø
MM112.12	-	without couplings
MM112.12 HGB 13	12	Hose tail 13 mm
MM112.12 HGB 16	12	Hose tail 16 mm
MM112.12 FGB 13	12	Push-Lock Hose tail 13 mm
MM112.12 FGB 16	12	Push-Lock Hose tail 16 mm
MM112.12 DGB 21	12	BSP female 1/2"
MM112.12 NGB 21	12	NPT female 1/2"

Part No.	Unit	Ø
MK112.12	-	without plugs
MK112.12 DUB 21	12	BSP female 1/2" with valve
MK112.12 NUB 21	12	NPT female 1/2" with valve
MK112.12 DU 21	12	BSP female 1/2" without valve
MK112.12 NU 21	12	NPT female 1/2" without valve

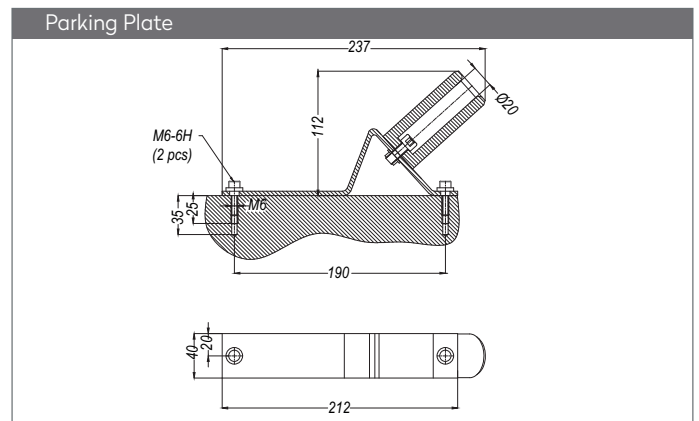
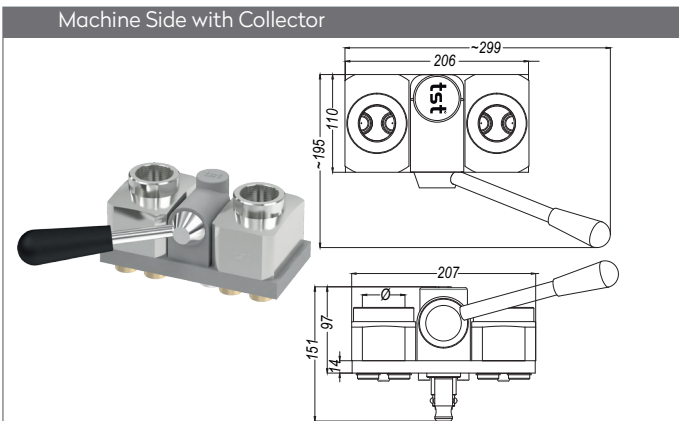

Part No.	Unit	Ø
MM112.12C33	12	BSP female 1"
MM112.12C42	12	BSP female 1 1/4"
MM112.12C48	12	BSP female 1 1/2"

Part No.
MM108.06 P

MULTICOUPLINGS

MULTIKUPPLUNGEN

5 ↔ 5

SERIE 112M

Multi Couplings Systems for quick changing of injection moulding and die cast equipments

Multikupplungensysteme für schnelles Wechseln und Verbinden der Kokillen und Spritzgußformen

Machine Side

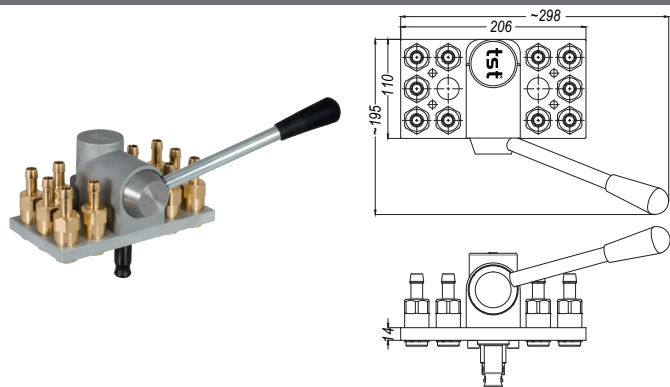

Mould Side

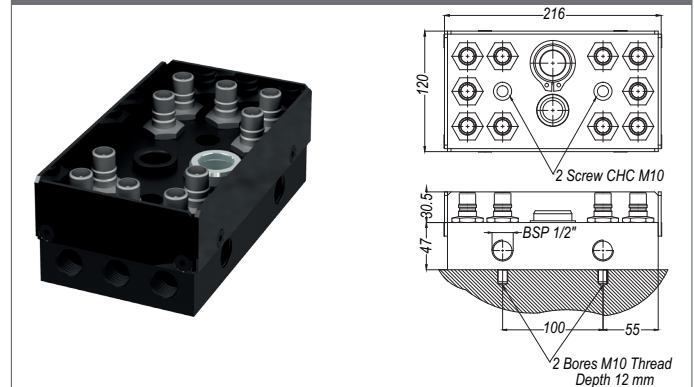

Part No.	Unit	Ø
MM112.12	-	without couplings
MM112.10 HGB 13	10	Hose tail 13 mm
MM112.10 HGB 16	10	Hose tail 16 mm
MM112.10 FGB 13	10	Push-Lock Hose tail 13 mm
MM112.10 FGB 16	10	Push-Lock Hose tail 16 mm
MM112.10 DGB 21	10	BSP female 1/2"
MM112.10 NGB 21	10	NPT female 1/2"

Part No.	Unit	Ø
MK112.10	10	BSP male 3/4" without valve
MK112.10V	10	BSP male 3/4" with valve

Parking Plate

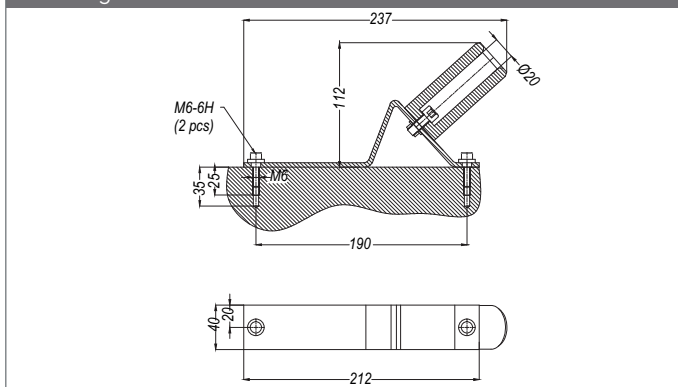

Mould Side

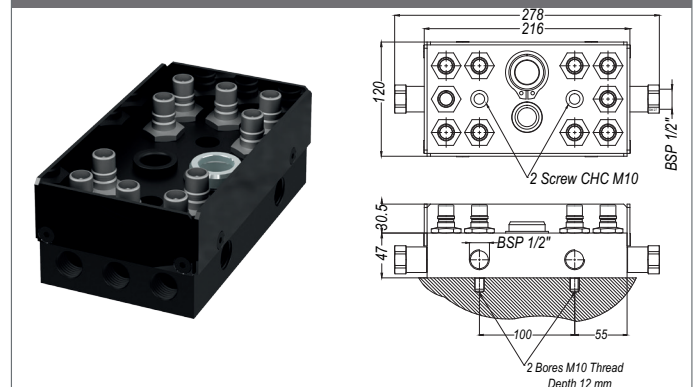

Part No.
MM108.06 P

Part No.	Unit	Ø
MK112.10EN21	10	BSP male 3/4" without valve
MK112.10EN21V	10	BSP male 3/4" with valve

SERIE 112M

Multi Couplings Systems for quick changing of injection moulding and die cast equipments

Multikupplungensysteme für schnelles Wechseln und Verbinden der Kokillen und Spritzgußformen

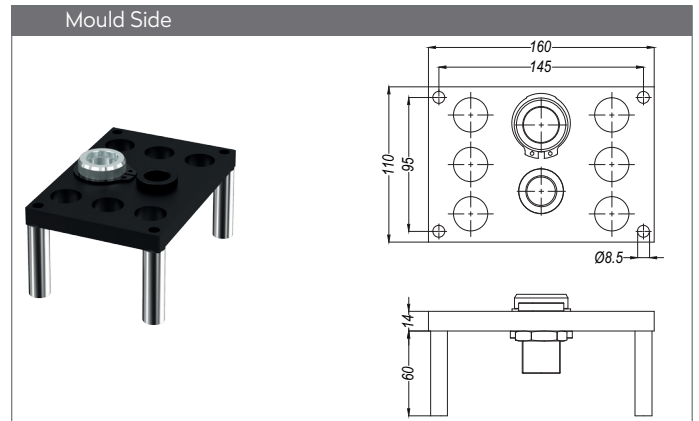
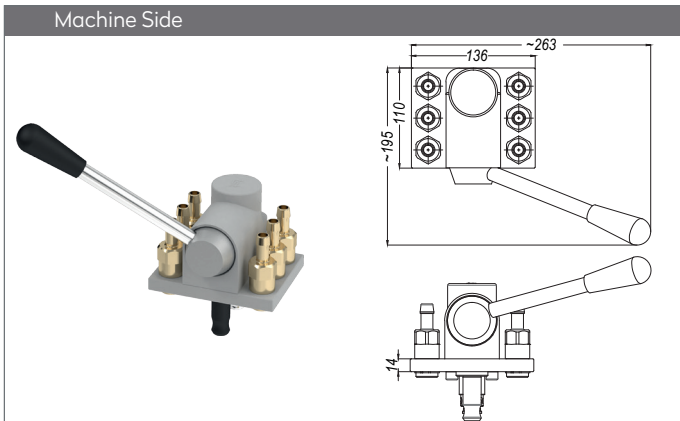

Part No.	Unit	Ø
MM112.06	-	without couplings
MM112.06 HGB 13	6	Hose tail 13 mm
MM112.06 HGB 16	6	Hose tail 16 mm
MM112.06 FGB 13	6	Push-Lock Hose tail 13 mm
MM112.06 FGB 16	6	Push-Lock Hose tail 16 mm
MM112.06 DGB 21	6	BSP female 1/2"
MM112.06 NGB 21	6	NPT female 1/2"

Part No.	Unit	Ø
MK112.06	-	without plugs
MK112.06 DUB 21	6	BSP female 1/2" with valve
MK112.06 NUB 21	6	NPT female 1/2" with valve
MK112.06 DU 21	6	BSP female 1/2" without valve
MK112.06 NU 21	6	NPT female 1/2" without valve

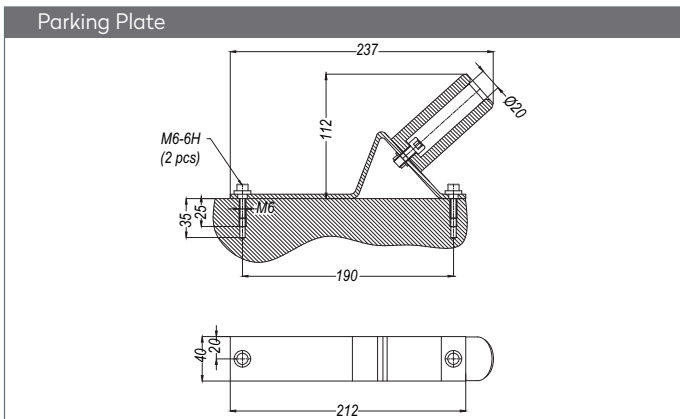

Part No.
MM108.06 P

MULTICOUPLINGS
 MULTIKUPPLUNGEN

SERIE 112M

QUICK COUPLINGS SCHNELLKUPPLUNGEN

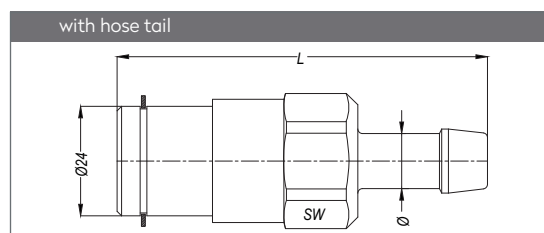

With Valve	Without Valve	SW	Ø	L
MM112 HGB 13	MM112 HGF 13	27	13	80.8
MM112 HGB 16	MM112 HGF 16	27	16	80.8

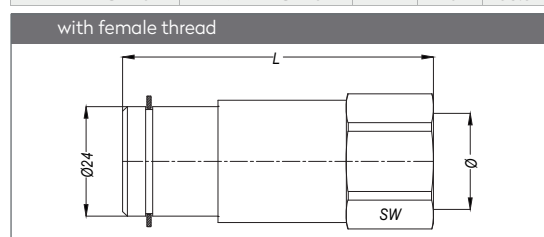

With Valve	Without Valve	SW	Ø	L
MM112 DGB 21	MM112 DGF 21	27	BSP 1/2"	67.8
MM112 NGB 21	MM112 NGF 21	27	NPT 1/2"	65.8

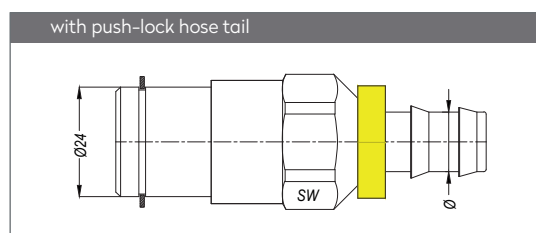

With Valve	Without Valve	SW	Ø	L
MM112 FGB 13	MM112 FGF 13	27	13	80.8
MM112 FGB 16	MM112 FGF 16	27	16	80.8

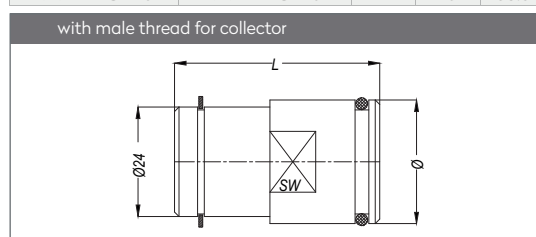

With Valve	Without Valve	SW	Ø	L
MM112 EGB 00	-	25	27	44.8

PLUGS STECKNIPPEL

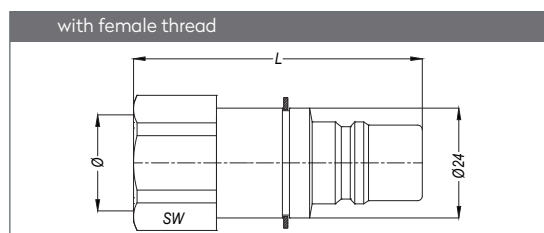

With Valve	Without Valve	SW	Ø	L
MK112 DUB 21	MK112 DUF 21	27	BSP 1/2"	63
MK112 NUB 21	MK112 NUF 21	27	NPT 1/2"	63

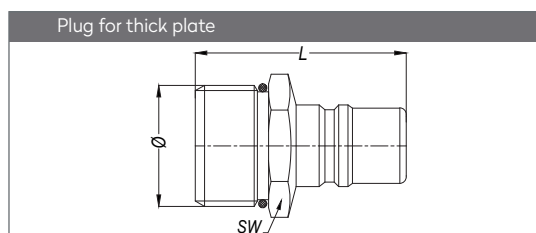

With Valve	Without Valve	SW	Ø	L
101.12 EUB 26	101.12 EUF 26	27	BSP 3/4"	46

ACCESSORIES ZUBEHÖR

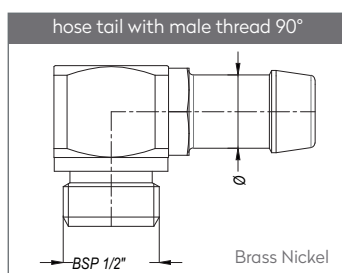

Part No.	Ø
112 EB 21.13	13
112 EB 21.16	16

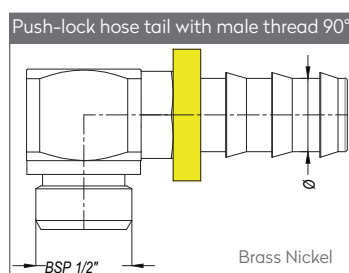

Part No.	Ø
112 EF 21.13	13
112 EF 21.16	16

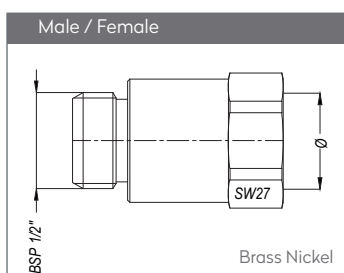

Part No.	Ø
112 EN 21	BSP 1/2"
112 NN 21	NPT 1/2"

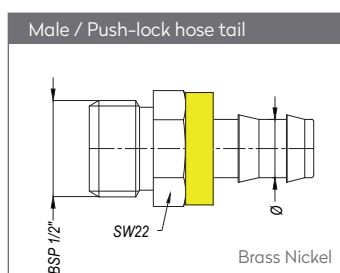

Part No.	Ø
EHF 21-13	13
EHF 21-16	16

Materials

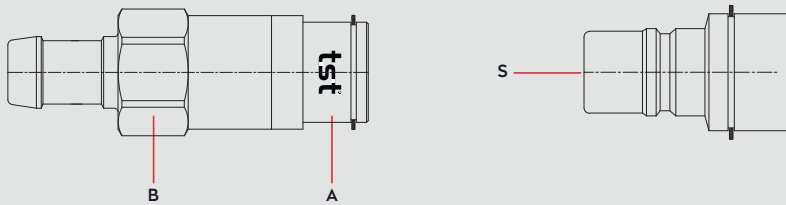

Material Code

- A = Brass
- B = Brass
- S = Brass Nickel Plated



0 - 16 bar



-26°C to + 200°C (FPM)

Shut Off Type

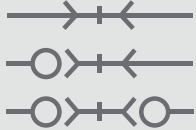
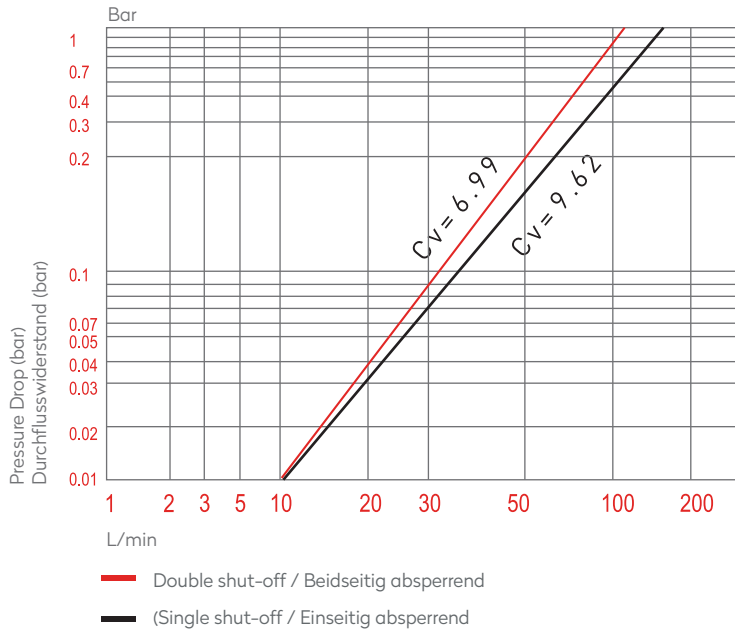
Options



COUPLING	OV 262 - 02105
	OV 262 - 01510
	OV 200 - 02000
PLUG	OV 262 - 01235

DN 16 mm

Applications

- Temperature controlling

Compatible with

6 ↔ 6

SERIE 116M

Multi Couplings Systems for quick changing of injection moulding and die cast equipments

Multikupplungensysteme für schnelles Wechseln und Verbinden der Kokillen und Spritzgußformen

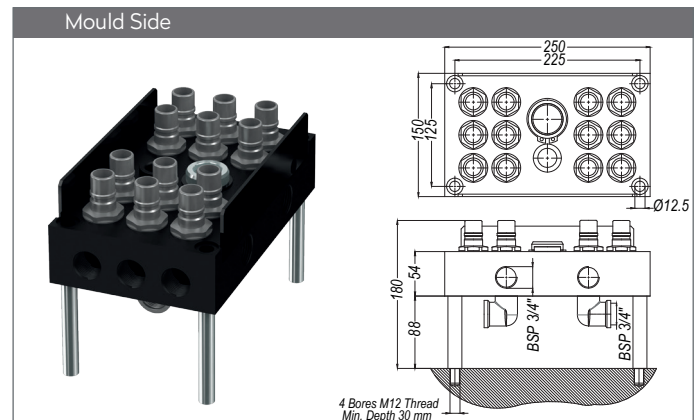
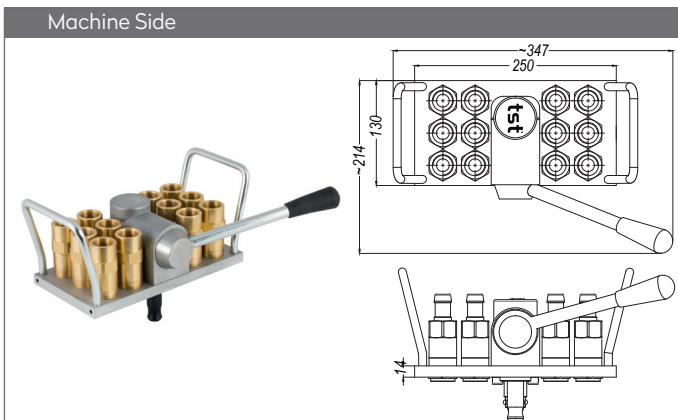

Part No.	Unit	Ø
MM116.12	-	without couplings
MM116.12 HGB 16	12	Hose tail 16 mm
MM116.12 HGB 19	12	Hose tail 19 mm
MM116.12 FGB 16	12	Push-Lock Hose tail 16 mm
MM116.12 FGB 19	12	Push-Lock Hose tail 19 mm
MM116.12 DGB 26	12	BSP female 3/4"
MM116.12 NGB 26	12	NPT female 3/4"

Part No.	Unit	Ø
MK116.12	12	BSP male 1" without valve
MK116.12N	12	NPT male 1" without valve
MK116.12V	12	BSP male 1" with valve
MK116.12NV	12	NPT male 1" with valve

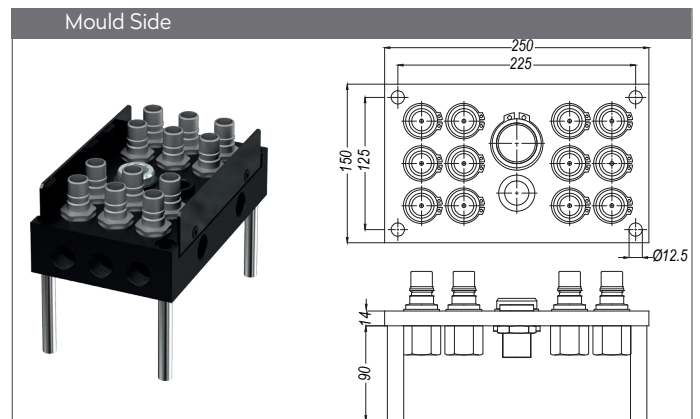
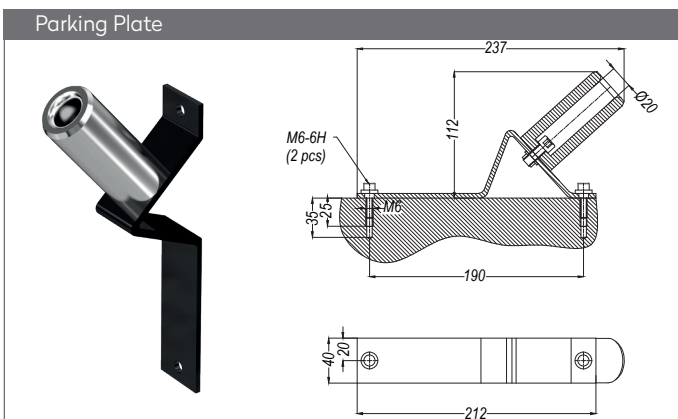

Part No.
MM108.06 P

Part No.	Unit	Ø
MK116.12-01	-	without plugs
MK116.12 DUB 26	12	BSP female 3/4" with valve
MK116.12 NUB 26	12	NPT female 3/4" with valve
MK116.12 DU 26	12	BSP female 3/4" without valve
MK116.12 NU 26	12	NPT female 3/4" without valve

SERIE 116M

Multi Couplings Systems for quick changing of injection moulding and die cast equipments

Multikupplungensysteme für schnelles Wechseln und Verbinden der Kokillen und Spritzgußformen

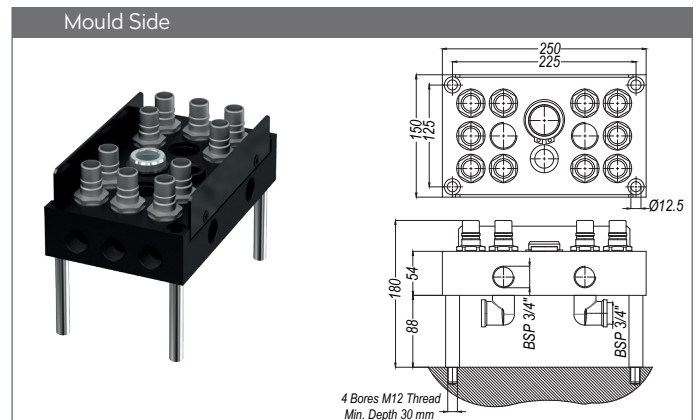
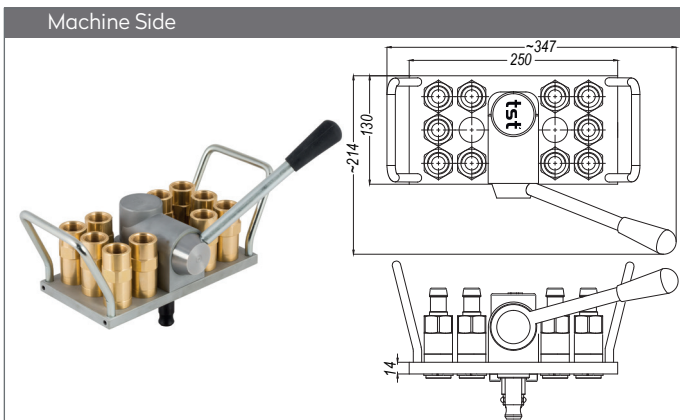

Part No.	Unit	Ø
MM116.12	-	without couplings
MM116.10 HGB 16	10	Hose tail 16 mm
MM116.10 HGB 19	10	Hose tail 19 mm
MM116.10 FGB 16	10	Push-Lock Hose tail 16 mm
MM116.10 FGB 19	10	Push-Lock Hose tail 19 mm
MM116.10 DGB 26	10	BSP female 3/4"
MM116.10 NGB 26	10	NPT female 3/4"

Part No.	Unit	Ø
MK116.10	10	BSP male 1" without valve
MK116.10N	10	NPT male 1" without valve
MK116.10V	10	BSP male 1" with valve
MK116.10NV	10	NPT male 1" with valve

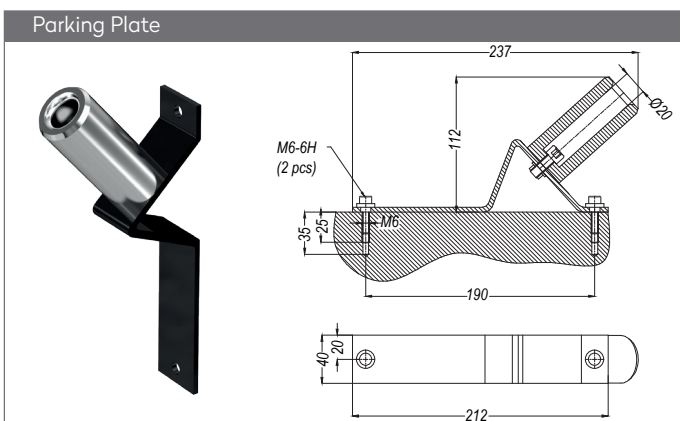

Part No.
MM108.06 P

SERIE 116M

QUICK COUPLINGS SCHNELLKUPPLUNGEN

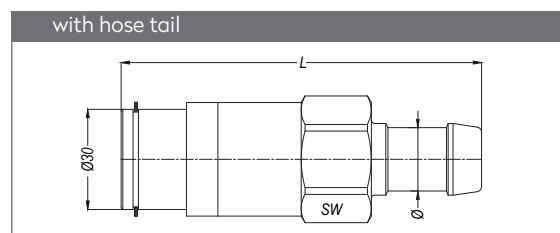

With Valve	Without Valve	SW	Ø	L
MM116 HGB 16	MM116 HGF 16	35	16	108
MM116 HGB 19	MM116 HGF 19	35	19	108

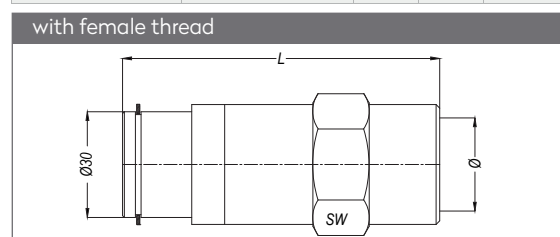

With Valve	Without Valve	SW	Ø	L
MM116 DGB 26	MM116 DGF 26	35	BSP 3/4"	90
MM116 NGB 26	MM116 NGF 26	35	NPT 3/4"	90

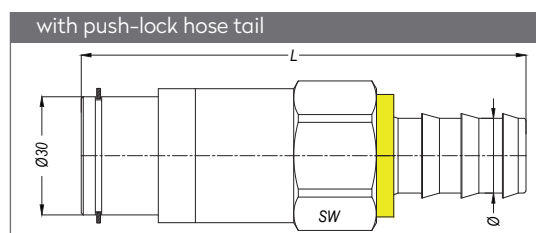

With Valve	Without Valve	SW	Ø	L
MM116 FGB 16	MM116 FGF 16	35	16	113
MM116 FGB 19	MM116 FGF 19	35	19	115

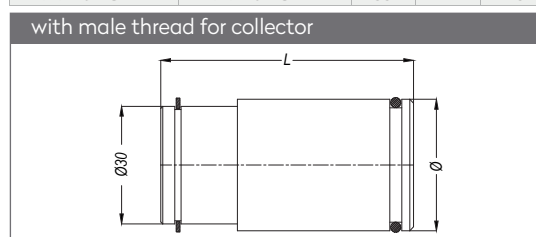

With Valve	Without Valve	SW	Ø	L
MM116 EGB 00	-	-	33.6	64.6

PLUGS STECKNIPPEL

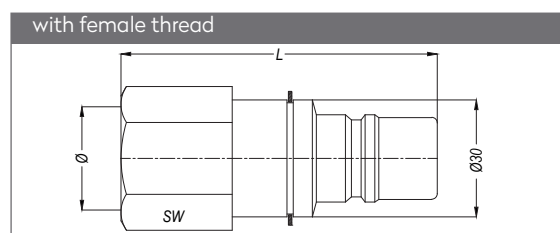

With Valve	Without Valve	SW	Ø	L
MK116 DUB 26	MK116 DUF 26	32	BSP 3/4"	81
MK116 NUB 26	MK116 NUF 26	34	NPT 3/4"	107

→*with adaptor

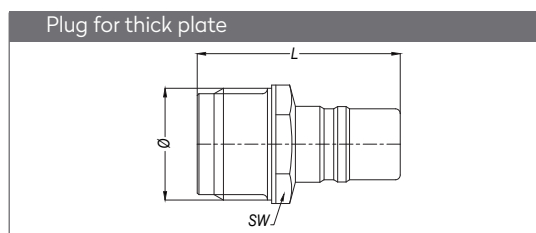

With Valve	Without Valve	SW	Ø	L
101.16 EUB 33	101.16 EUP 33	32	BSP 1"	60

ACCESSORIES ZUBEHÖR

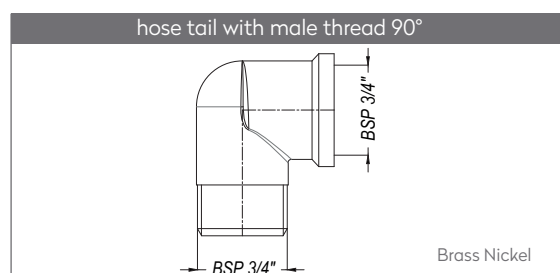

Part No.
116 EB 26

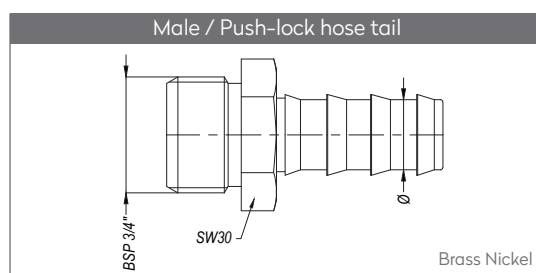

Part No.	Ø
EHF 26-16	16
EHF 26-19	19

SERIE 104.06 / 104.08

5 ↔ 5

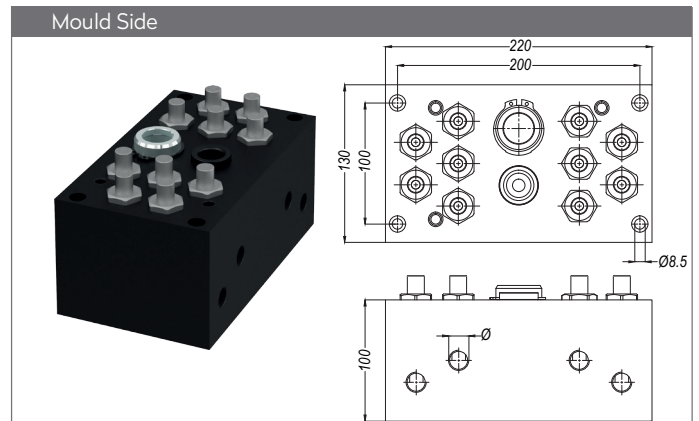
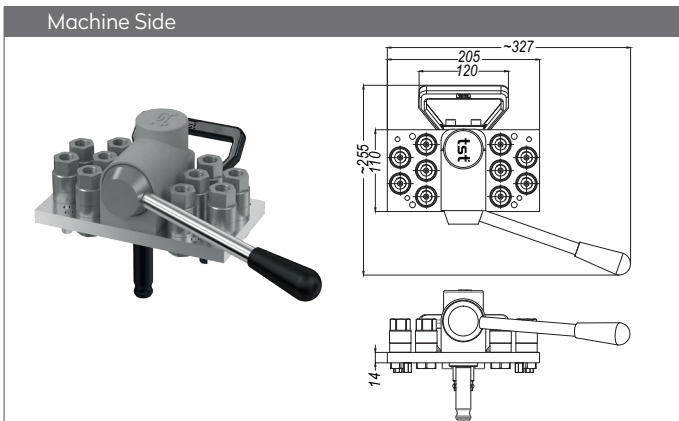

Part No.	Unit	Ø
	-	without plugs
MM104.06-10 DGB17	10	104.06 DGB 17MP (3/8" BSP)
MM104.06-10 NGB17	10	104.06 NGB 17MP (3/8" NPT)

Part No.	Unit	Ø
	-	without plugs
MK104.06-10 G17	10	104.06 EUBM 24MP (M24 male)
	10	3/8" BSP female thread holes on sides
MK104.06-10 N17	10	104.06 EUBM 24MP (M24 male)
	10	3/8" NPT female thread holes on sides

4 ↔ 4

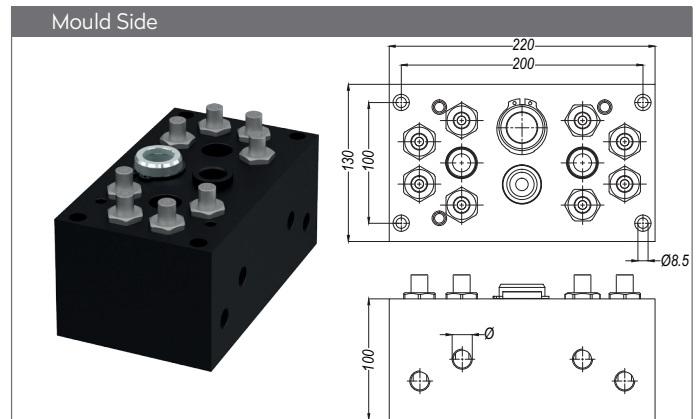
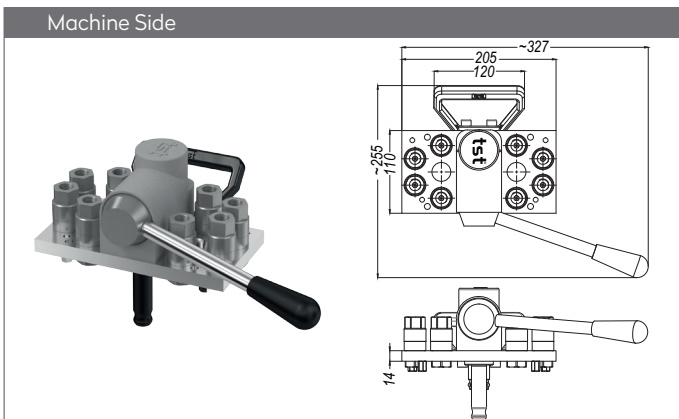

Part No.	Unit	Ø
	-	without plugs
MM104.06.08-10 DGB17	8	104.06 DGB 17MP (3/8" BSP)
MM104.06.08-10 NGB17	8	104.06 NGB 17MP (3/8" NPT)

Part No.	Unit	Ø
	-	without plugs
MK104.06.08-10 G17	8	104.06 EUBM 24MP (M24 male)
	10	3/8" BSP female thread holes on sides
MK104.06.08-10 N17	8	104.06 EUBM 24MP (M24 male)
	10	3/8" NPT female thread holes on sides

MULTICOUPLINGS
 MULTIKUPPLUNGEN

SERIE 104.06 / 104.08

QUICK COUPLINGS SCHNELLKUPPLUNGEN

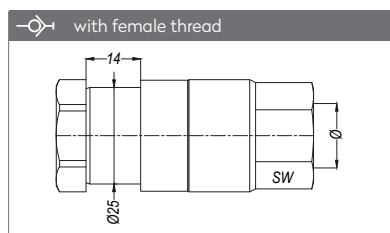

Part no.	Ø	SW
104.06 DGB 17 MP	BSP 3/8"	24
104.06 NGB 17 MP	NPT 3/8"	24

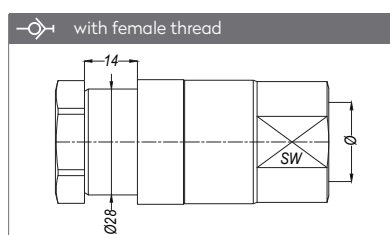

Part no.	Ø	SW
104.08 DGB 21 MP	BSP 1/2"	29
104.08 NGB 21 MP	NPT 1/2"	29

PLUGS STECKNIPPEL

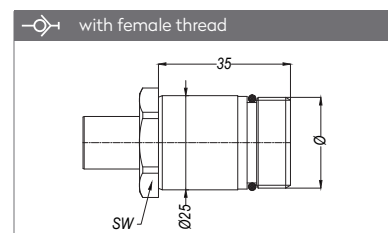

Part no.	Ø	SW
104.06 EUBM 24 MP	M24x1.5	26

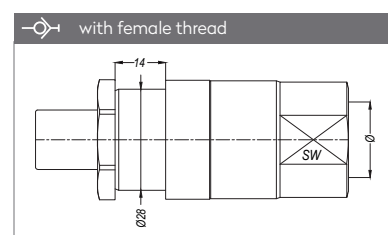

Part no.	Ø	SW
104.08 DUB 21 MP	BSP 1/2"	24
104.08 NUB 21 MP	NPT 1/2"	24

EF/ EM

ELECTRICAL CONNECTORS (Silvered)
 ELEKTROSTECKER (Versilbert)

High Pressure Hydraulic Flash Faced
 Multicoupling Systems with electrical connector
 Hydraulische Multikupplungen für
 Hochdruck in Leckgereier Ausführung mit Elektrostecker

Inserts	No of Pins	Ø Pins Or Socket mm	Current for each Pins in use (A)	Voltage (V)	Cross Section Of the connection Vire (mm ²)	Part no.	
						Socket Inserts & Carrier Body (EF)	Pins Inserts & Carrier Body (EM)
	5 4 + Earth	3	27 Per pin	400	2.5 - 4	36002FA - P014 - 0530	36002MA - P014 - 0530
	7 6 + Earth	3	27 Per pin	400	2.5 - 4	36002FA - P014 - 0730	36002MA - P014 - 0730
	16 15 + Earth	2	27 Per pin	250	0.5 - 1.5	36002FA - P014 - 1620	36002MA - P014 - 1620
	16 15 + Earth	1.5	16 Per pin	250	0.5 - 1.5	36002FA - P014 - 1615	36002MA - P014 - 1615

Materials

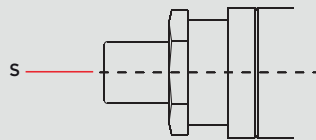
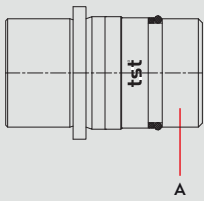

Material Code

A = AISI 303

S = AISI 420



0 - 180 bar



-26°C to + 200°C (FPM)

Shut Off Type



FF

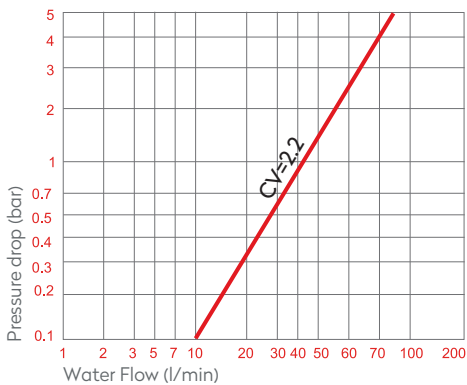

QUICK COUPLINGS SCHNELLKUPPLUNGEN

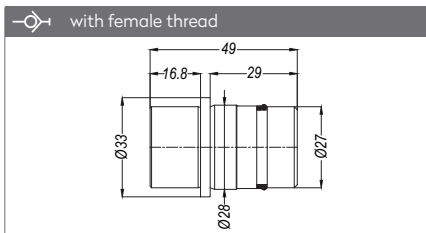

Part no.
MK104.08 DGB 00

PLUGS STECKNIPPEL

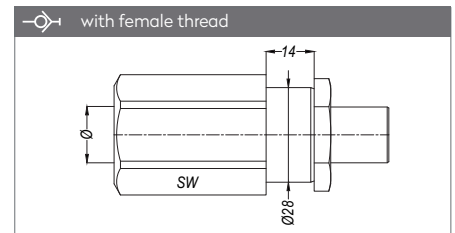

Part no.	Ø	SW
104.08 DUB 17 MP	BSP 3/8"	32
104.08 DUB 21 MP	BSP 1/2"	32
104.08 NUB 17 MP	NPT 3/8"	32
104.08 NUB 21 MP	NPT 1/2"	32

Options

PD

HF



MK COUPLING
MM PLUG

- OV 178 - 02195 - 88
- OV 200 - 00550 - 88
- OV 262 - 01715 - 88
- OV 262 - 01715 - 88
- OV 178 - 02195 - 88
- OV 200 - 00550 - 88

Applications

- Hydraulic Circuits

DN

8 mm

Compatible with

MULTICOUPLINGS
 MULTIKUPPLUNGEN

3 ↔ 3

SERIE 108M

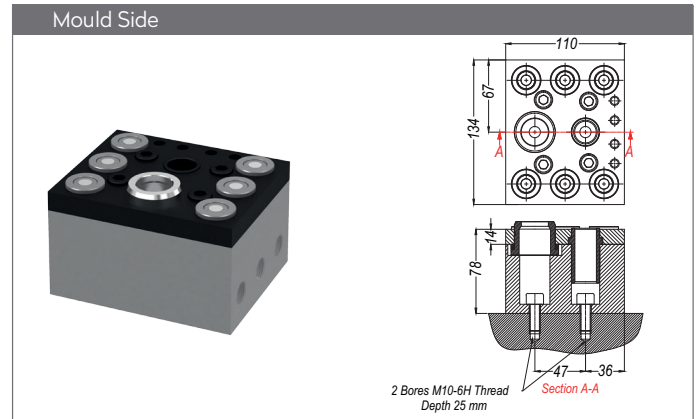
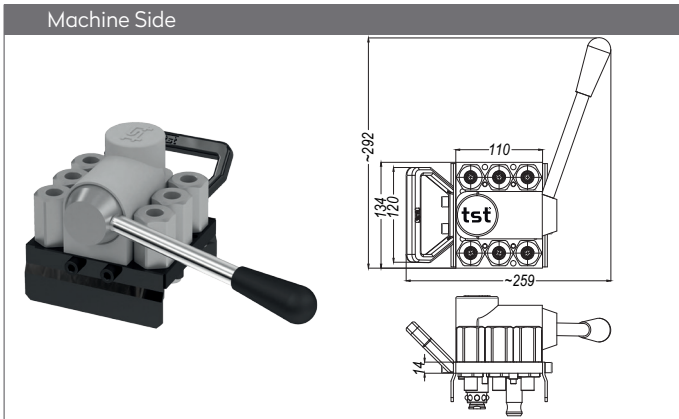

Part No.	Unit	Ø
	-	without plugs
MM108.06 G17	6	104.08 DUB 17MP (3/8" BSP)
MM108.06 G21	6	104.08 DUB 21MP (1/2" BSP)
MM108.06 N17	6	104.08 NUB 17MP (3/8" NPT)
MM108.06 N21	6	104.08 NUB 21MP (1/2" NPT)
MM108.06 U14	6	104.08 UUB 14MP (9/16" UNF)
MM108.06 U19	6	104.08 UUB 19MP (3/4" UNF)

Part No.	Unit	Ø
	-	without couplings
MK108.06 G17	6	MK104.08 DGB 00
	6	3/8" BSP female thread holes on sides
MK108.06 G21	6	MK104.08 DGB 00
	6	1/2" BSP female thread holes on sides
MK108.06 N17	6	104.08 NGB 17MP (3/8" NPT)
	6	3/8" NPT female thread holes on sides
MK108.06 N21	6	104.08 NGB 21MP (1/2" NPT)
	6	1/2" NPT female thread holes on sides
MK108.06 U14	6	104.08 UUB 14MP (9/16" UNF)
	6	9/16" UNF female thread holes on sides
MK108.06 U19	6	104.08 UUB 19MP (3/4" UNF)
	6	3/4" UNF female thread holes on sides

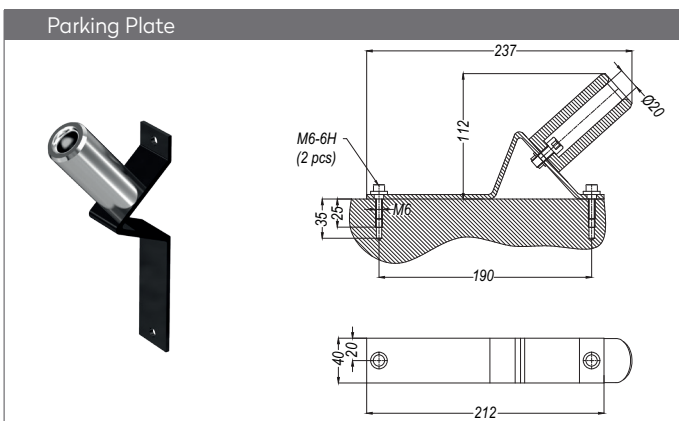

Part No.
MM108.06 P

SERIE 108M

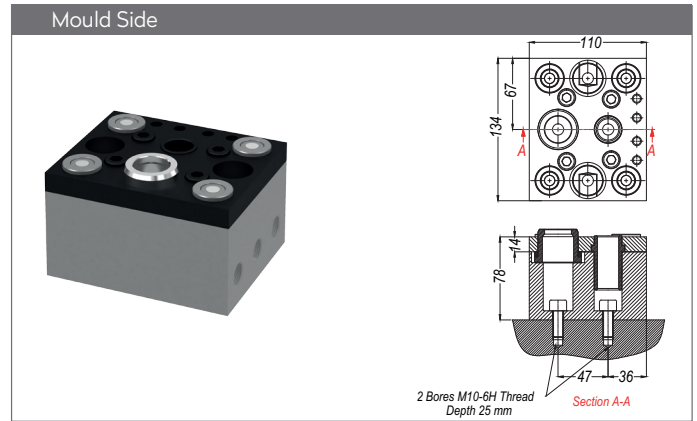
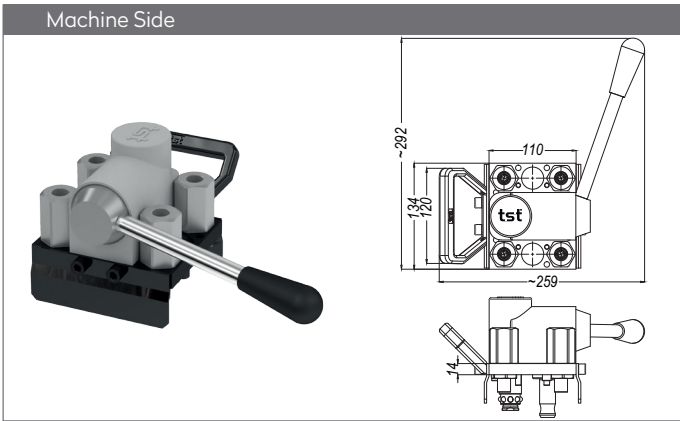

Part No.	Unit	Ø
	-	without plugs
MM108.04 G17	4	104.08 DUB 17MP (3/8" BSP)
MM108.04 G21	4	104.08 DUB 21MP (1/2" BSP)
MM108.04 N17	4	104.08 NUB 17MP (3/8" NPT)
MM108.04 N21	4	104.08 NUB 21MP (1/2" NPT)
MM108.04 U14	4	104.08 UUB 14MP (9/16" UNF)
MM108.04 U19	4	104.08 UUB 19MP (3/4" UNF)

Part No.	Unit	Ø
	-	without couplings
MK108.04 G17	4	MK104.08 DGB 00
	6	3/8" BSP female thread holes on sides
MK108.04 G21	4	MK104.08 DGB 00
	6	1/2" BSP female thread holes on sides
MK108.04 N17	4	104.08 NGB 17MP (3/8" NPT)
	6	3/8" NPT female thread holes on sides
MK108.04 N21	4	104.08 NGB 21MP (1/2" NPT)
	6	1/2" NPT female thread holes on sides
MK108.04 U14	4	104.08 UUB 14MP (9/16" UNF)
	6	9/16" UNF female thread holes on sides
MK108.04 U19	4	104.08 UUB 19MP (3/4" UNF)
	6	3/4" UNF female thread holes on sides

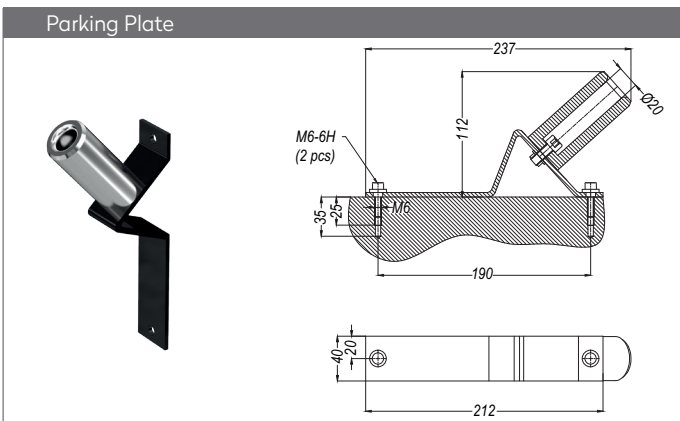

Part No.
MM108.06 P

MULTICOUPLINGS
 MULTIKUPPLUNGEN

1 ⇌ 1

SERIE 108M

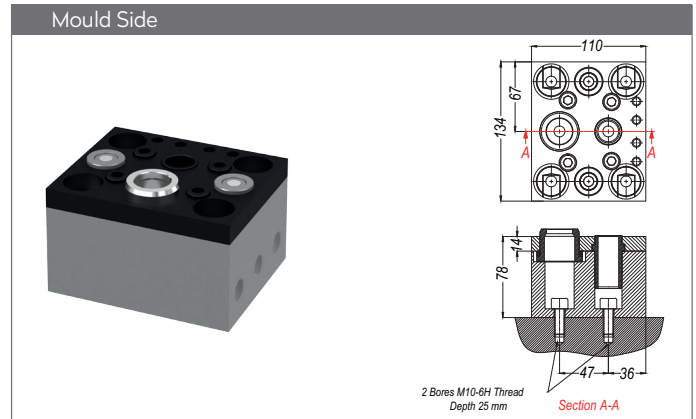
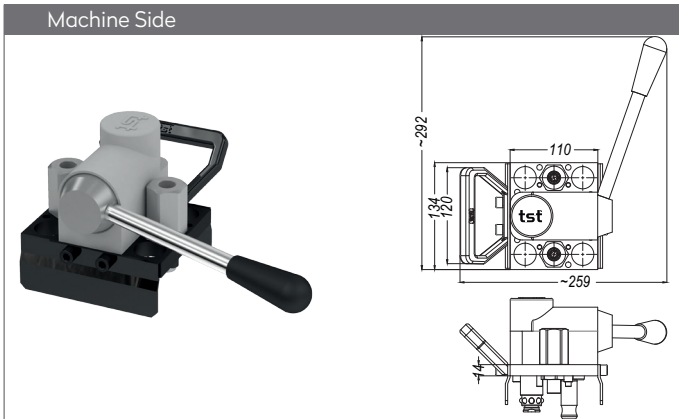

Part No.	Unit	Ø
	-	without plugs
MM108.02 G17	2	104.08 DUB 17MP (3/8" BSP)
MM108.02 G21	2	104.08 DUB 21MP (1/2" BSP)
MM108.02 N17	2	104.08 NUB 17MP (3/8" NPT)
MM108.02 N21	2	104.08 NUB 21MP (1/2" NPT)
MM108.02 U14	2	104.08 UUB 14MP (9/16" UNF)
MM108.02 U19	2	104.08 UUB 19MP (3/4" UNF)

Part No.	Unit	Ø
	-	without couplings
MK108.02 G17	2	MK104.08 DGB 00
	6	3/8" BSP female thread holes on sides
MK108.02 G21	2	MK104.08 DGB 00
	6	1/2" BSP female thread holes on sides
MK108.02 N17	2	104.08 NGB 17MP (3/8" NPT)
	6	3/8" NPT female thread holes on sides
MK108.02 N21	2	104.08 NGB 21MP (1/2" NPT)
	6	1/2" NPT female thread holes on sides
MK108.02 U14	2	104.08 UUB 14MP (9/16" UNF)
	6	9/16" UNF female thread holes on sides
MK108.02 U19	2	104.08 UUB 19MP (3/4" UNF)
	6	3/4" UNF female thread holes on sides

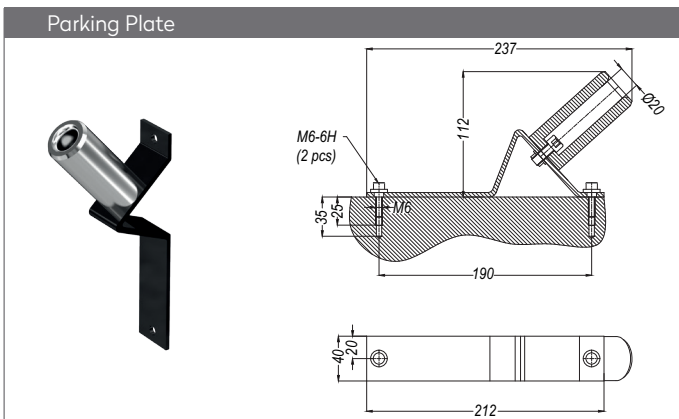

Part No.
MM108.06 P

Materials

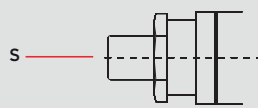
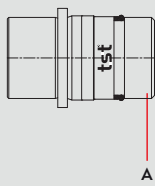

SCREW LOCKING

Material Code

A = AISI 303

S = AISI 420



0 - 180 bar



-26°C to + 200°C (FPM)

Shut Off Type



FF

Water 5m/sec. 20°C

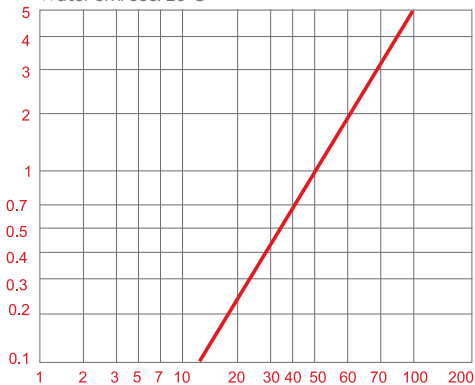

Water Flow l / min
Pressure Drop (bar)

QUICK COUPLINGS SCHNELLKUPPLUNGEN

with female thread

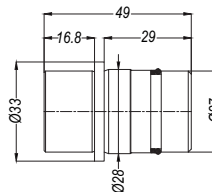

Part no.

MK104.10 DGB 00

PLUGS STECKNIPPEL

with female thread

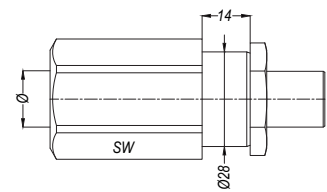

Part no.

Ø

SW

104.10 DUB 17 MP	BSP 3/8"	32
104.10 DUB 21 MP	BSP 1/2"	32
104.10 NUB 17 MP	NPT 3/8"	32
104.10 NUB 21 MP	NPT 1/2"	32

Options

PD



MMK
COUPLING
MM
PLUG

OV 262 - 01905 - 88
OV 178 - 01280 - 88
OV 178 - 02195 - 88
OV 190 - 00930 - 88
OV 178 - 02195 - 88
OV 262 - 01715 - 88

Applications

• Hydraulic Circuits

DN

10 mm

Compatible with

MULTICOUPLINGS

MULTIKUPPLUNGEN

3 ↔ 3

SERIE 108M-HF

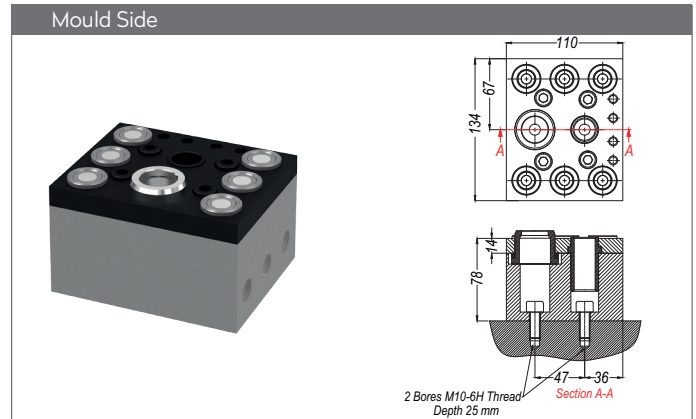
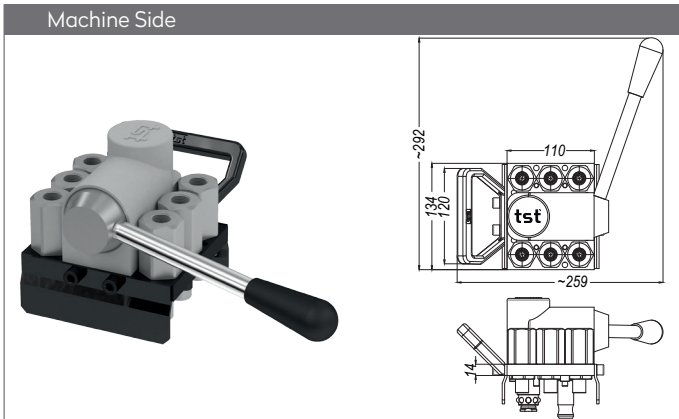

Part No.	Unit	Ø
	-	without plugs
MM108.06 G17-HF	6	104.10 DUB 17MP (3/8" BSP)
MM108.06 G21-HF	6	104.10 DUB 21MP (1/2" BSP)
MM108.06 N17-HF	6	104.10 NUB 17MP (3/8" NPT)
MM108.06 N21-HF	6	104.10 NUB 21MP (1/2" NPT)
MM108.06 U14-HF	6	104.10 UUB 14MP (9/16" UNF)
MM108.06 U19-HF	6	104.10 UUB 19MP (3/4" UNF)

Part No.	Unit	Ø
	-	without couplings
MK108.06 G17-HF	6	MK104.10 DGB 00
	6	3/8" BSP female thread holes on sides
MK108.06 G21-HF	6	MK104.10 DGB 00
	6	1/2" BSP female thread holes on sides
MK108.06 N17-HF	6	104.10 NGB 17MP (3/8" NPT)
	6	3/8" NPT female thread holes on sides
MK108.06 N21-HF	6	104.10 NGB 21MP (1/2" NPT)
	6	1/2" NPT female thread holes on sides
MK108.06 U14-HF	6	104.10 UUB 14MP (9/16" UNF)
	6	9/16" UNF female thread holes on sides
MK108.06 U19-HF	6	104.10 UUB 19MP (3/4" UNF)
	6	3/4" UNF female thread holes on sides

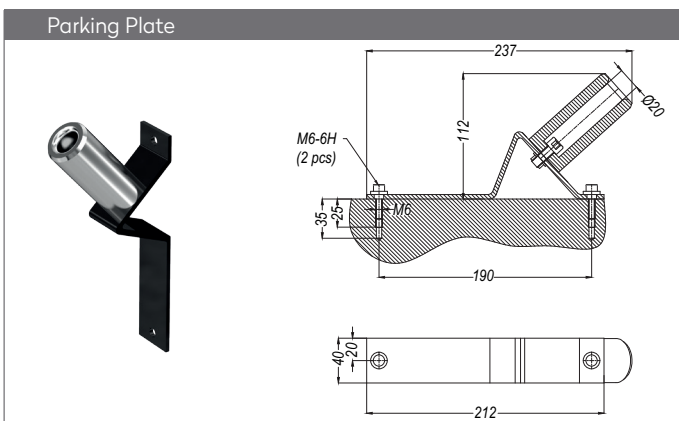

Part No.
MM108.06 P

SERIE 108M-HF

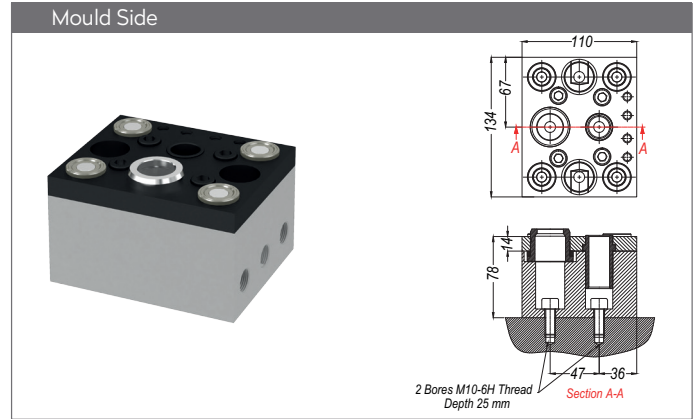
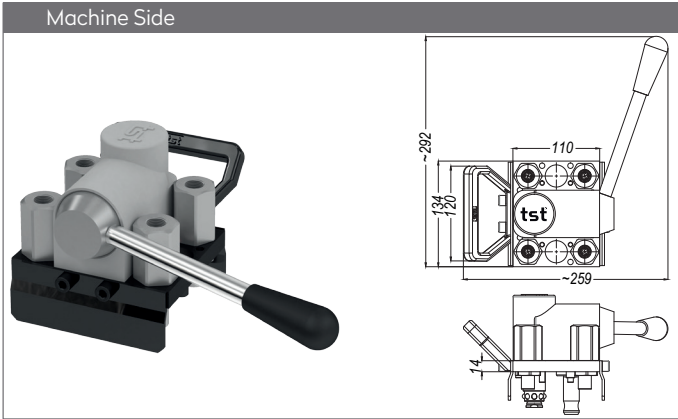

Part No.	Unit	Ø
	-	without plugs
MM108.04 G17-HF	4	104.10 DUB 17MP (3/8" BSP)
MM108.04 G21-HF	4	104.10 DUB 21MP (1/2" BSP)
MM108.04 N17-HF	4	104.10 NUB 17MP (3/8" NPT)
MM108.04 N21-HF	4	104.10 NUB 21MP (1/2" NPT)
MM108.04 U14-HF	4	104.10 UUB 14MP (9/16" UNF)
MM108.04 U19-HF	4	104.10 UUB 19MP (3/4" UNF)

Part No.	Unit	Ø
	-	without couplings
MK108.04 G17-HF	4	MK104.10 DGB 00
	6	3/8" BSP female thread holes on sides
MK108.04 G21-HF	4	MK104.10 DGB 00
	6	1/2" BSP female thread holes on sides
MK108.04 N17-HF	4	MK104.10 DGB 00
	6	3/8" NPT female thread holes on sides
MK108.04 N21-HF	4	MK104.10 DGB 00
	6	1/2" NPT female thread holes on sides
MK108.04 U14-HF	4	MK104.10 DGB 00
	6	9/16" UNF female thread holes on sides
MK108.04 U19-HF	4	MK104.10 DGB 00
	6	3/4" UNF female thread holes on sides

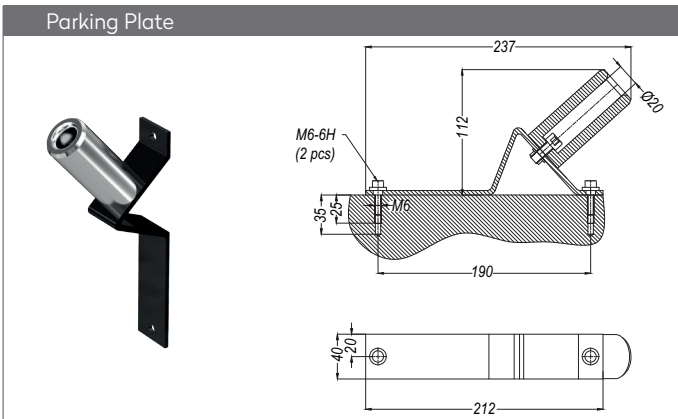

Part No.
MM108.06 P

MULTICOUPLINGS
 MULTIKUPPLUNGEN

1 ⇌ 1

SERIE 108M-HF

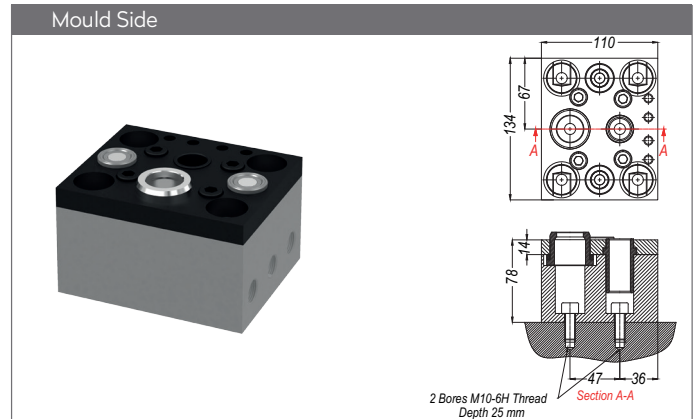
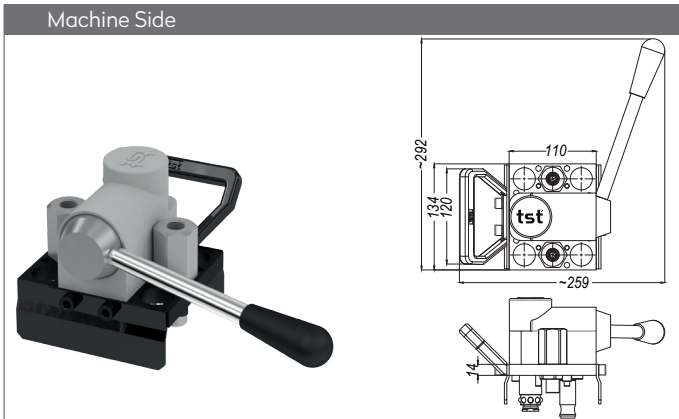

Part No.	Unit	Ø
	-	without plugs
MM108.02 G17-HF	2	104.10 DUB 17MP (3/8" BSP)
MM108.02 G21-HF	2	104.10 DUB 21MP (1/2" BSP)
MM108.02 N17-HF	2	104.10 NUB 17MP (3/8" NPT)
MM108.02 N21-HF	2	104.10 NUB 21MP (1/2" NPT)
MM108.02 U14-HF	2	104.10 UUB 14MP (9/16" UNF)
MM108.02 U19-HF	2	104.10 UUB 19MP (3/4" UNF)

Part No.	Unit	Ø
	-	without couplings
MK108.02 G17-HF	2	MK104.10 DGB 00
	6	3/8" BSP female thread holes on sides
MK108.02 G21-HF	2	MK104.10 DGB 00
	6	1/2" BSP female thread holes on sides
MK108.02 N17-HF	2	MK104.10 DGB 00
	6	3/8" NPT female thread holes on sides
MK108.02 N21-HF	2	MK104.10 DGB 00
	6	1/2" NPT female thread holes on sides
MK108.02 U14-HF	2	MK104.10 DGB 00
	6	9/16" UNF female thread holes on sides
MK108.02 U19-HF	2	MK104.10 DGB 00
	6	3/4" UNF female thread holes on sides

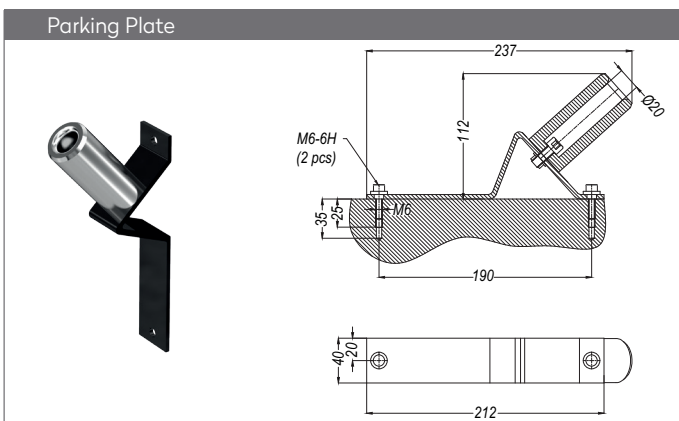

Part No.
MM108.06 P

MULTICOUPLINGS (ELECTRICAL)
MULTIKUPPLUNGEN (ELEKTRISCH)

SERIE 108ME

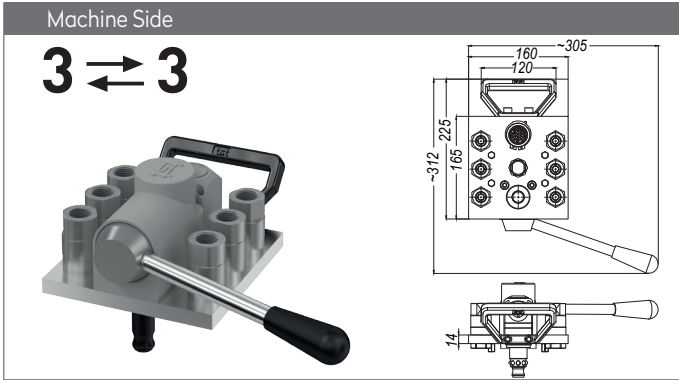

Part No.	Unit	Ø
	-	without couplings
MM104.08E-0706-Z14	6	104.08 DGB 21MP (1/2" BSP)
MM104.08E-0706-Z17	6	104.08 NGB 21MP (1/2" NPT)

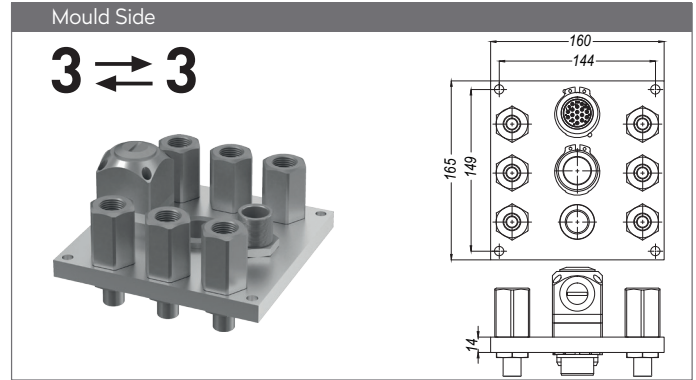

Part No.	Unit	Ø
	-	without plugs
MK104.08E-0706-Z14	6	104.08 DUB 21MP (1/2" BSP)
MK104.08E-0706-Z17	6	104.08 NUB 21MP (1/2" NPT)

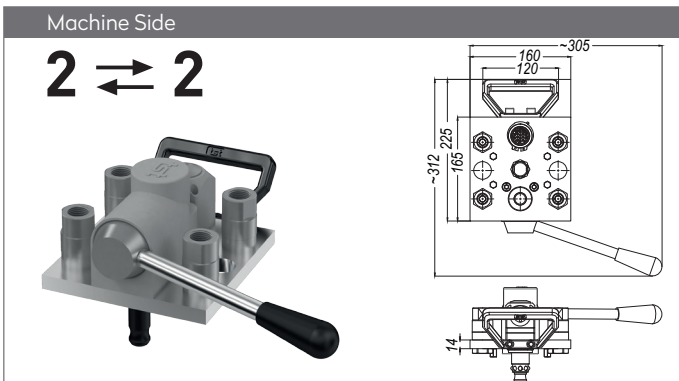

Part No.	Unit	Ø
	-	without couplings
MM104.08E-0706-Z15	4	104.08 DGB 21MP (1/2" BSP)
MM104.08E-0706-Z18	4	104.08 NGB 21MP (1/2" NPT)

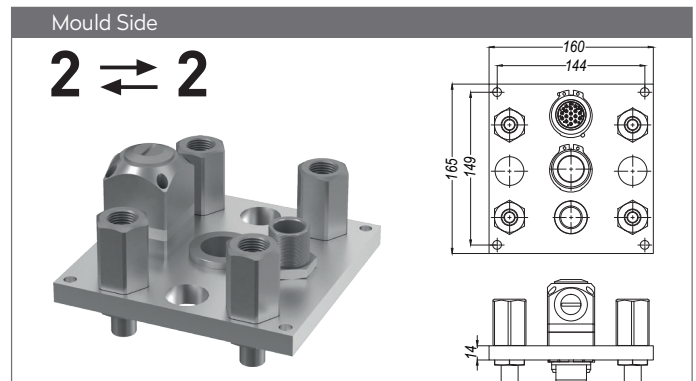

Part No.	Unit	Ø
	-	without plugs
MK104.08E-0706-Z15	4	104.08 DUB 21MP (1/2" BSP)
MK104.08E-0706-Z18	4	104.08 NUB 21MP (1/2" NPT)

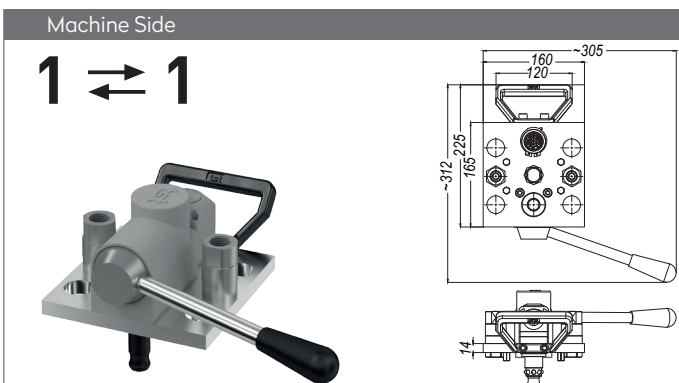

Part No.	Unit	Ø
	-	without couplings
MM104.08E-0706-Z16	2	104.08 DGB 21MP (1/2" BSP)
MM104.08E-0706-Z19	2	104.08 NGB 21MP (1/2" NPT)

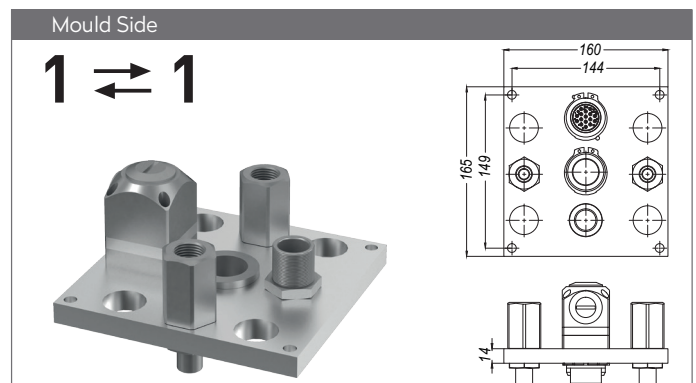

Part No.	Unit	Ø
	-	without plugs
MK104.08E-0706-Z16	2	104.08 DUB 21MP (1/2" BSP)
MK104.08E-0706-Z19	2	104.08 NUB 21MP (1/2" NPT)

DN3

MULTICOUPLINGS
MULTIKUPPLUNGEN

SERIE 115.03M

Materials

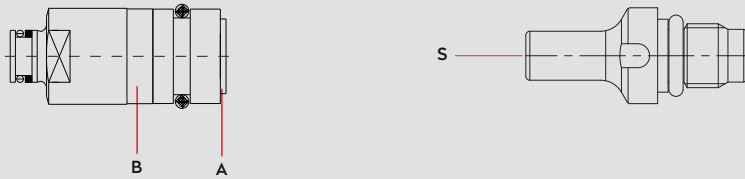

Material Code

A = AISI 303

B = AISI 303

S = AISI 420





0 - 100 bar



-26°C to + 200°C (FPM)

Shut Off Type



	COUPLING	OV 157 - 00600 OV 178 - 01000	OV 100 - 00400 - 88 OV 140 - 00850 - 88 OV 100 - 00180 - 88	TC 0865-0620-06 TC 0580-0440-07
	PLUG	OV 178 - 00975 - 88 OV 100 - 00180 - 88	OV 100 - 00700-88 OV 100 - 00400	TC 0840-0700-07 TC 0580-0440-07

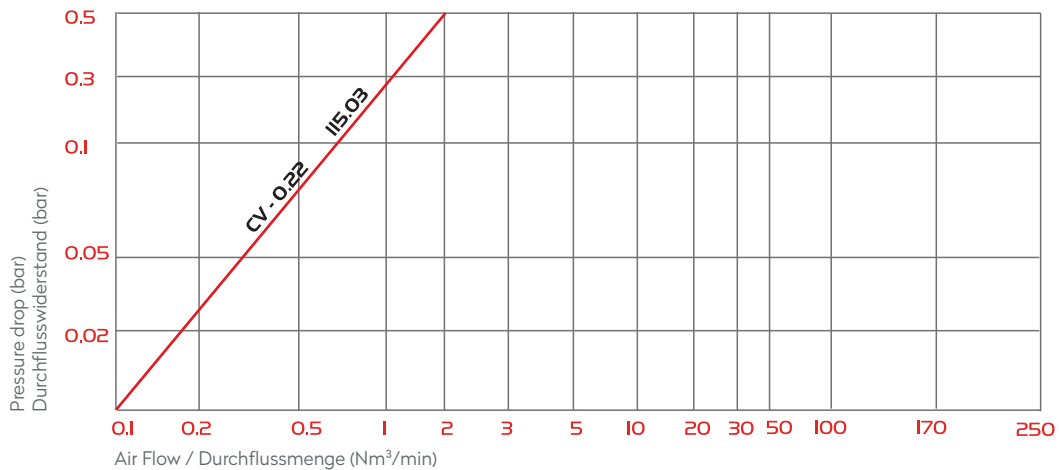

FF

Applications

- Quick mould change
- Hot runner systems

DN 3 mm

Compatible with

SERIE 115.03M

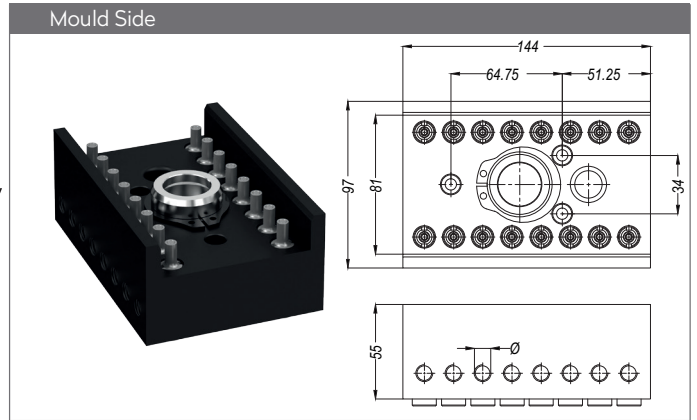
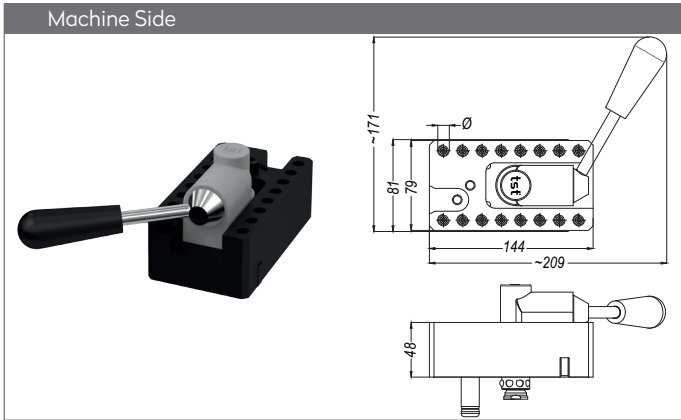

Part No.	Unit	Ø
MM115.03-00-16G10	-	without couplings
MM115.03-16 G 10	16	115.03 EGB 00 (FF)
	16	1/8" BSP female thread side holes empty
MM115.03-16 N 10	16	115.03 EGB 00 (FF)
	16	1/8" NPT female thread adaptors on sides
MM115.03-16 Q 10	16	115.03 EGB 00 (FF)
	16	1/8" BSPT female thread adaptors on sides

Part No.	Unit	Ø
MK115.03-00-16G10	-	without plugs
MK115.03-16 G 10	16	115.03 EUBM 08 (FF)
	16	1/8" BSP female thread side holes empty
MK115.03-16 N 10	16	115.03 EUBM 08 (FF)
	16	1/8" NPT female thread adaptors on sides
MK115.03-16 Q 10	16	115.03 EUBM 08 (FF)
	16	1/8" BSPT female thread adaptors on sides

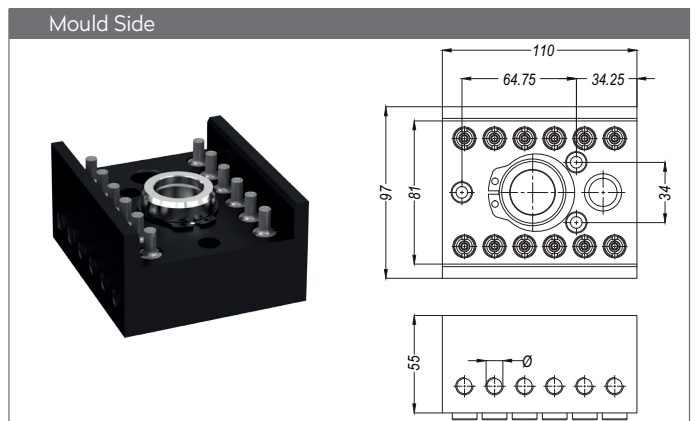
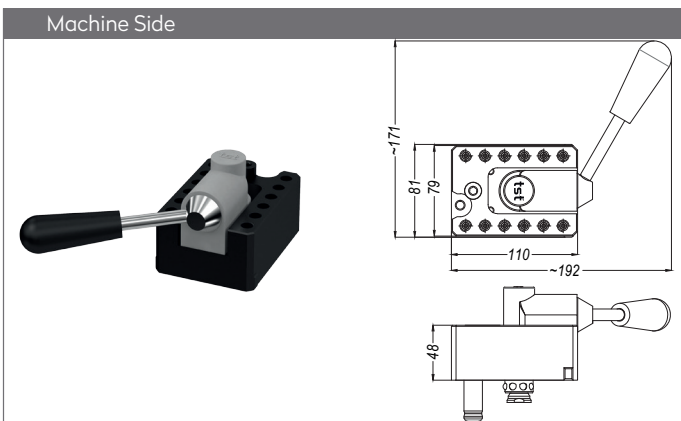

Part No.	Unit	Ø
MM115.03-00G10	-	without couplings
MM115.03-12 G 10	12	115.03 EGB 00 (FF)
	12	1/8" BSP female thread side holes empty
MM115.03-12 N 10	12	115.03 EGB 00 (FF)
	12	1/8" NPT female thread adaptors on sides
MM115.03-12 Q 10	12	115.03 EGB 00 (FF)
	12	1/8" BSPT female thread adaptors on sides

Part No.	Unit	Ø
MK115.03-00G10	-	without plugs
MK115.03-12 G 10	12	115.03 EUBM 08 (FF)
	12	1/8" BSP female thread side holes empty
MK115.03-12 N 10	12	115.03 EUBM 08 (FF)
	12	1/8" NPT female thread adaptors on sides
MK115.03-12 Q 10	12	115.03 EUBM 08 (FF)
	12	1/8" BSPT female thread adaptors on sides

MULTICOUPLINGS

MULTIKUPPLUNGEN

SERIE 115.03M

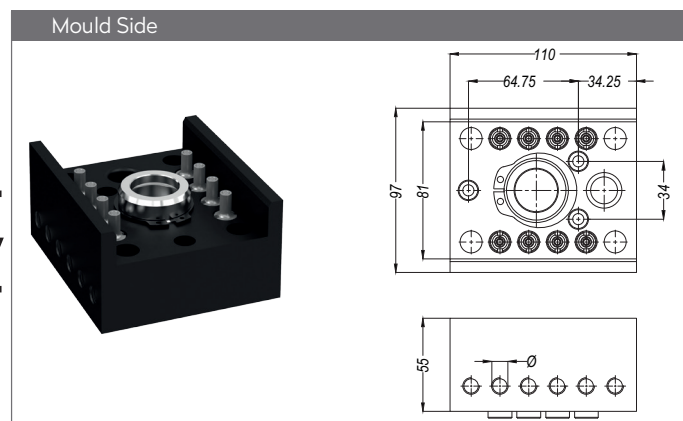
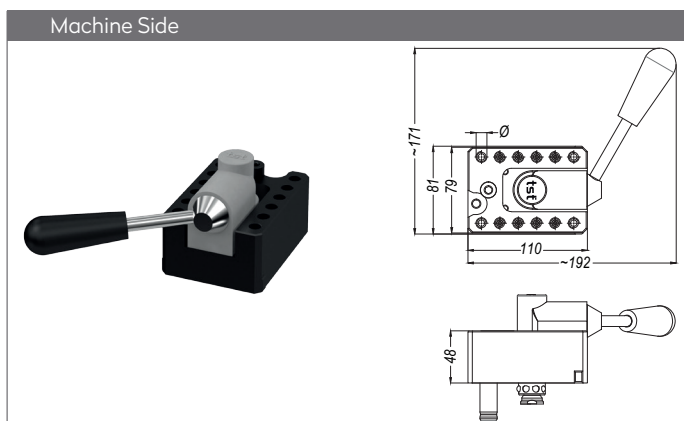

Part No.	Unit	Ø
MM115.03-00G10	-	without couplings
MM115.03-08 G 10	8	115.03 EGB 00 (FF)
	12	1/8" BSP female thread side holes empty
MM115.03-08 N 10	8	115.03 EGB 00 (FF)
	12	1/8" NPT female thread adaptors on sides
MM115.03-08 Q 10	8	115.03 EGB 00 (FF)
	12	1/8" BSPT female thread adaptors on sides

Part No.	Unit	Ø
MK115.03-00G10	-	without plugs
MK115.03-08 G 10	8	115.03 EUBM 08 (FF)
	12	1/8" BSP female thread side holes empty
MK115.03-08 N 10	8	115.03 EUBM 08 (FF)
	12	1/8" NPT female thread adaptors on sides
MK115.03-08 Q 10	8	115.03 EUBM 08 (FF)
	12	1/8" BSPT female thread adaptors on sides

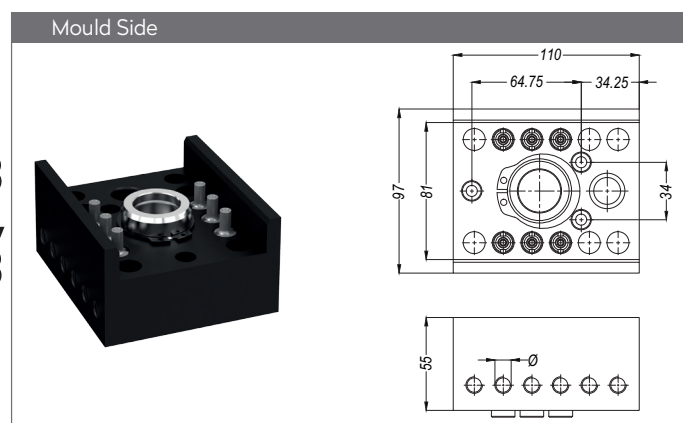
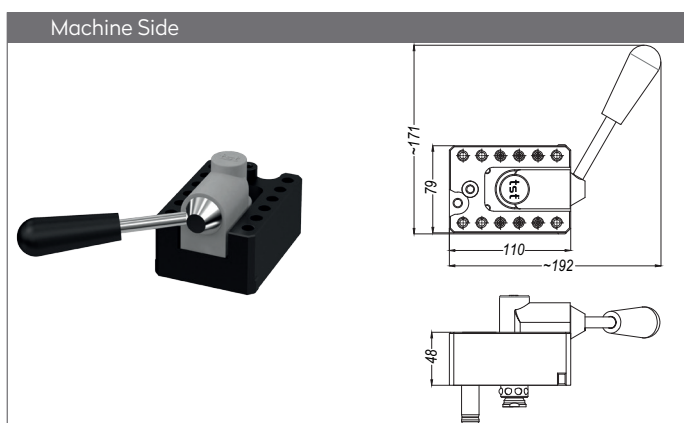

Part No.	Unit	Ø
MM115.03-00G10	-	without couplings
MM115.03-06 G 10	6	115.03 EGB 00 (FF)
	12	1/8" BSP female thread side holes empty
MM115.03-06 N 10	6	115.03 EGB 00 (FF)
	12	1/8" NPT female thread adaptors on sides
MM115.03-06 Q 10	6	115.03 EGB 00 (FF)
	12	1/8" BSPT female thread adaptors on sides

Part No.	Unit	Ø
MK115.03-00G10	-	without plugs
MK115.03-06 G 10	6	115.03 EUBM 08 (FF)
	12	1/8" BSP female thread side holes empty
MK115.03-06 N 10	6	115.03 EUBM 08 (FF)
	12	1/8" NPT female thread adaptors on sides
MK115.03-06 Q 10	6	115.03 EUBM 08 (FF)
	12	1/8" BSPT female thread adaptors on sides

MULTICOUPLINGS
MULTIKUPPLUNGEN

SERIE 115.03M

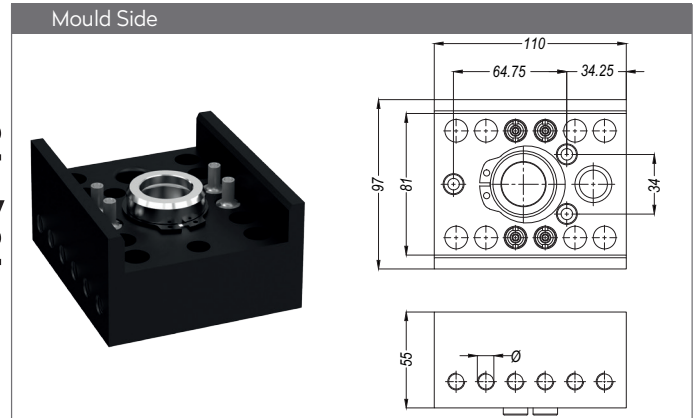
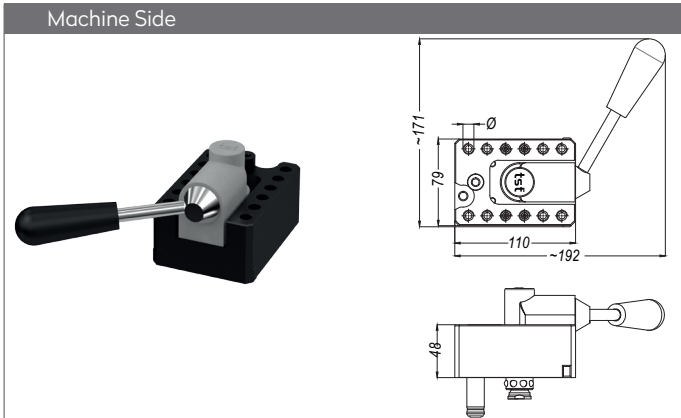

2
↕
2

Part No.	Unit	Ø
MM115.03-00G10	-	without couplings
MM115.03-04 G 10	4	115.03 EGB 00 (FF)
	12	1/8" BSP female thread side holes empty
MM115.03-04 N 10	4	115.03 EGB 00 (FF)
	12	1/8" NPT female thread adaptors on sides
MM115.03-04 Q 10	4	115.03 EGB 00 (FF)
	12	1/8" BSPT female thread adaptors on sides

Part No.	Unit	Ø
MK115.03-00G10	-	without plugs
MK115.03-04 G 10	4	115.03 EUBM 08 (FF)
	12	1/8" BSP female thread side holes empty
MK115.03-04 N 10	4	115.03 EUBM 08 (FF)
	12	1/8" NPT female thread adaptors on sides
MK115.03-04 Q 10	4	115.03 EUBM 08 (FF)
	12	1/8" BSPT female thread adaptors on sides

QUICK COUPLINGS SCHNELLKUPPLUNGEN

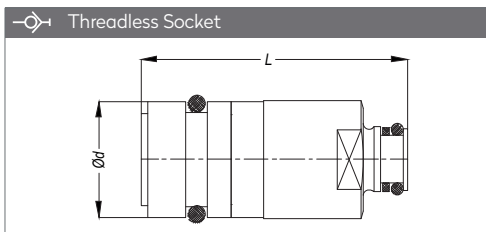

Part no.	DN	Ø	L	ØD
115.03 EGB 00	Ø 3 mm	Ring Special	32.6	13



Part no.
115.03 ATS 00



Part no.
115.03 ATS 08

VALVED PLUGS VERSCHLUßNIPPEL

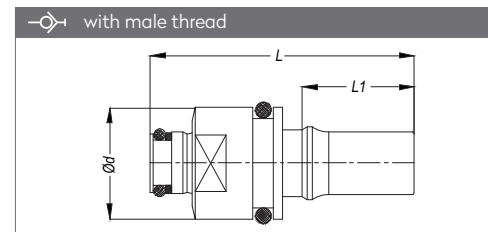

Part no.	DN	Ø	L	L1	ØD
115.03 EUBM 08	Ø 3 mm	M 8x1	27.8	16.5	12

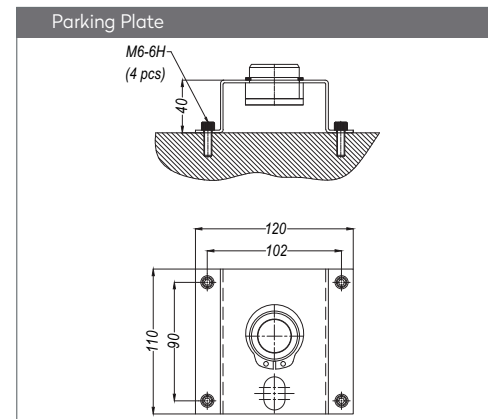

Part No.
MM115.03-12 P

DN5

MULTICOUPLINGS
MULTIKUPPLUNGEN

SERIE 115.05M

Materials



Material Code

A = AISI 303

B = AISI 303

S = AISI 420





0 - 100 bar



-26°C to + 200°C (FPM)

Shut Off Type



	COUPLING	OV 200 - 01000 - 88 OV 178 - 0720 - 88	OV 157 - 01300 - 88 OV 190 - 00580 - 88 OV 262 - 01435	TC 1360 - 1035 - 06 TC 1000 - 0740 - 10
	PLUG	OV 100 - 00180 - 88 OV 178 - 00605 - 88		

FF

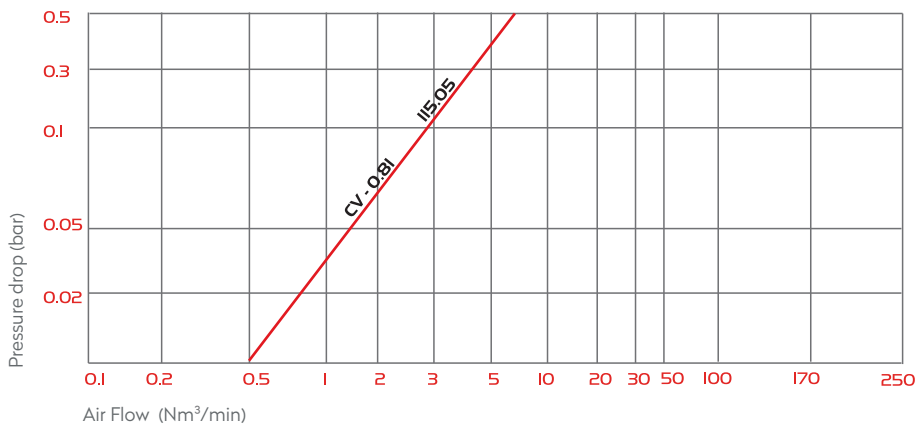

Options

LS
(Screw type)

Applications

- Quick mould change
- Hot runner systems

DN **5** mm

SERIE **115.05M****115.05**

Nominal / Nennweite	Ø(mm)	5
Cross section / Querschnitt	(mm)	19.6
Max. working pressure / Max. Betriebsdruck	(bar)	300
Weight of socket / Gewicht der Kupplung	(g)	48.5
Weight of plug in house Gewicht der gesteckten Verschlussnippel	(g)	32
Weight of threaded plug Gewicht der eingeschraubten Verschlussnippel	(g)	22.5
Air Introducing at Connection Lufteingang bei der Einkuppelung	(cm ³)	0.024
Water spillage at disconnection Wasserverlust bei der Auskuppelung	(cm ³)	0.014
Connection force Kuppelkraft	(N)	59

MULTICOUPLINGS

MULTIKUPPLUNGEN

8 ↔ 8

SERIE 115.05M

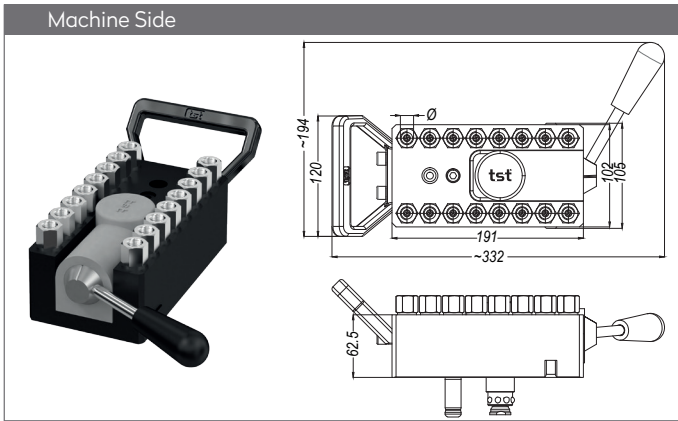

Part No.	Unit	Ø
MM115.05-00-16G13	-	without couplings
MM115.05-16 G 13	16	115.05 EGB 00 (FF)
	16	1/4" BSP female thread side holes empty
MM115.05-16 N 13	16	115.05 EGB 00 (FF)
	16	1/4" NPT female thread adaptors on sides
MM115.05-16 Q 13	16	115.05 EGB 00 (FF)
	16	1/4" BSPT female thread adaptors on sides
MM115.05-16 U 14	16	115.05 EGB 00 (FF)
	16	9/16" UNF female thread adaptors on sides

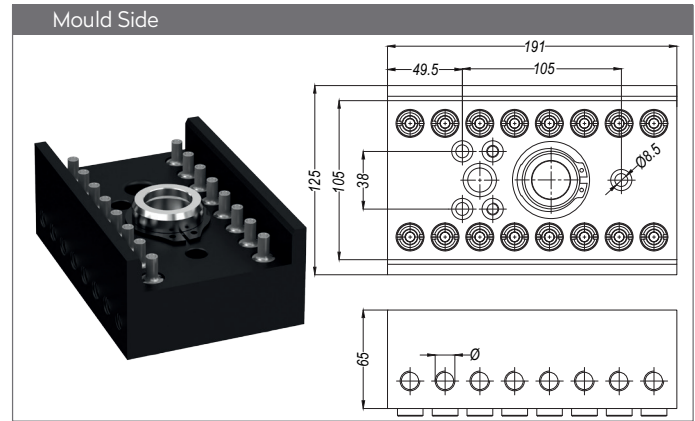

Part No.	Unit	Ø
MK115.05-00-16G13	-	without plugs
MK115.05-16 G 13	16	115.05 EUBM 14 (FF)
	16	1/4" BSP female thread side holes empty
MK115.05-16 N 13	16	115.05 EUBM 14 (FF)
	16	1/4" NPT female thread adaptors on sides
MK115.05-16 Q 13	16	115.05 EUBM 14 (FF)
	16	1/4" BSPT female thread adaptors on sides
MK115.05-16 U 14	16	115.05 EUBM 14 (FF)
	16	9/16" UNF female thread adaptors on sides

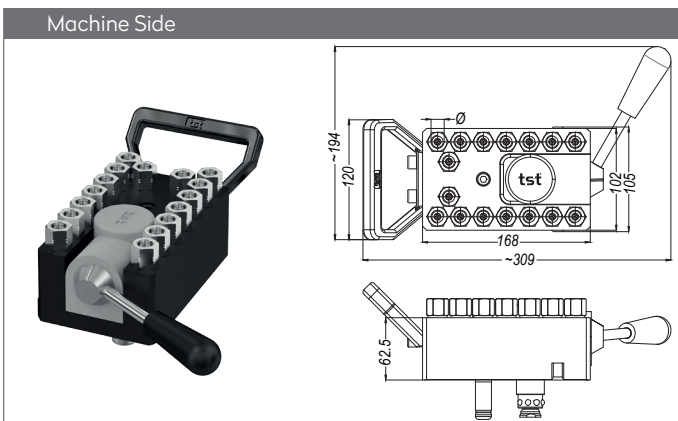

Part No.	Unit	Ø
MM115.05-00-16G13-SP01	-	without couplings
MM115.05-16 G 13-SP01	16	115.05 EGB 00 (FF)
	16	1/4" BSP female thread side holes empty
MM115.05-16 N 13-SP01	16	115.05 EGB 00 (FF)
	16	1/4" NPT female thread adaptors on sides
MM115.05-16 Q 13-SP01	16	115.05 EGB 00 (FF)
	16	1/4" BSPT female thread adaptors on sides
MM115.05-16 U 14-SP01	16	115.05 EGB 00 (FF)
	16	9/16" UNF female thread adaptors on sides

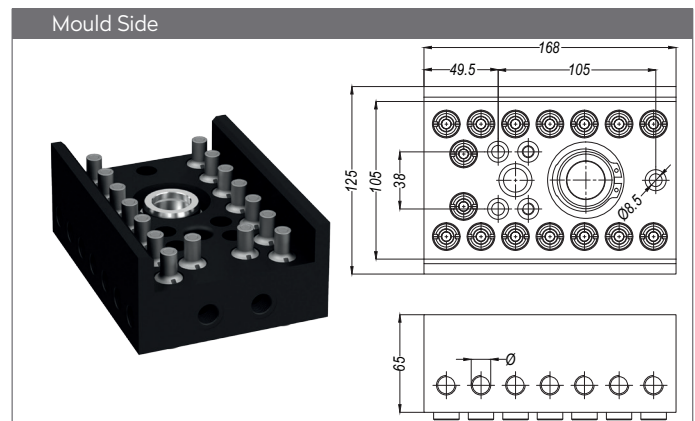

Part No.	Unit	Ø
MK115.05-00-16G13-SP01	-	without plugs
MK115.05-16 G 13-SP01	16	115.05 EUBM 14 (FF)
	16	1/4" BSP female thread side holes empty
MK115.05-16 N 13-SP01	16	115.05 EUBM 14 (FF)
	16	1/4" NPT female thread adaptors on sides
MK115.05-16 Q 13-SP01	16	115.05 EUBM 14 (FF)
	16	1/4" BSPT female thread adaptors on sides
MK115.05-16 U 14-SP01	16	115.05 EUBM 14 (FF)
	16	9/16" UNF female thread adaptors on sides

MULTICOUPLINGS
MULTIKUPPLUNGEN

SERIE 115.05M

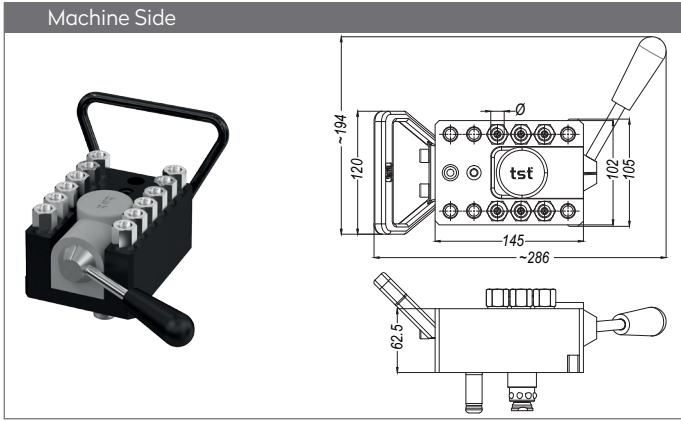

Part No.	Unit	Ø
MM115.05-00G13	-	without couplings
MM115.05-12 G 13	12	115.05 EGB 00 (FF)
	12	1/4" BSP female thread side holes empty
MM115.05-12 N 13	12	115.05 EGB 00 (FF)
	12	1/4" NPT female thread adaptors on side
MM115.05-12 Q 13	12	115.05 EGB 00 (FF)
	12	1/4" BSPT female thread adaptors on side
MM115.05-12 U 14	12	115.05 EGB 00 (FF)
	12	9/16" UNF female thread adaptors on side

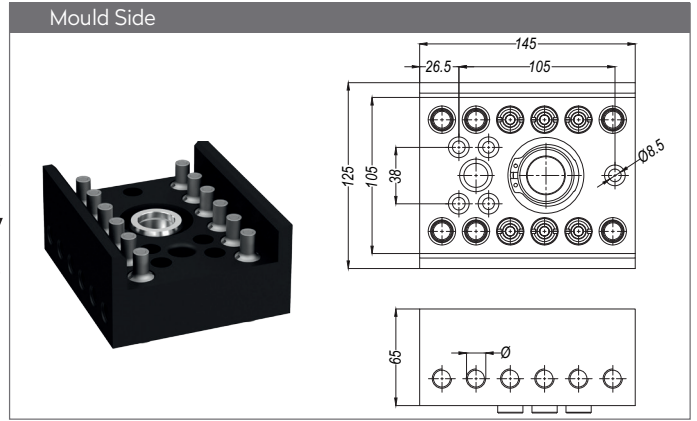

Part No.	Unit	Ø
MK115.05-00G13	-	without plugs
MK115.05-12 G 13	12	115.05 EUBM 14 (FF)
	12	1/4" BSP female thread side holes empty
MK115.05-12 N 13	12	115.05 EUBM 14 (FF)
	12	1/4" NPT female thread adaptors on side
MK115.05-12 Q 13	12	115.05 EUBM 14 (FF)
	12	1/4" BSPT female thread adaptors on side
MK115.05-12 U 14	12	115.05 EUBM 14 (FF)
	12	9/16" UNF female thread adaptors on side

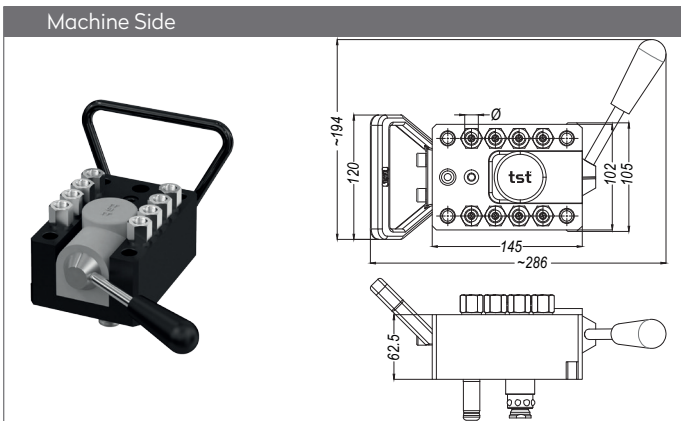

Part No.	Unit	Ø
MM115.05-00G13	-	without couplings
MM115.05-08 G 13	8	115.05 EGB 00 (FF)
	8	1/4" BSP female thread side holes empty
MM115.05-08 N 13	8	115.05 EGB 00 (FF)
	8	1/4" NPT female thread adaptors on side
MM115.05-08 Q 13	8	115.05 EGB 00 (FF)
	8	1/4" BSPT female thread adaptors on side
MM115.05-08 U 14	8	115.05 EGB 00 (FF)
	8	9/16" UNF female thread adaptors on side

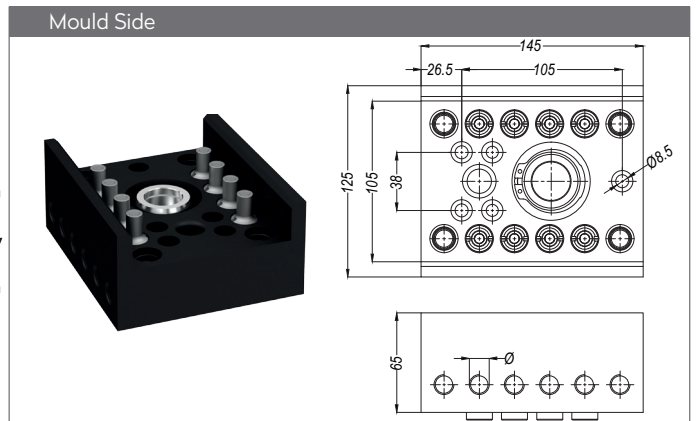

Part No.	Unit	Ø
MK115.05-00G13	-	without plugs
MK115.05-08 G 13	8	115.05 EUBM 14 (FF)
	8	1/4" BSP female thread side holes empty
MK115.05-08 N 13	8	115.05 EUBM 14 (FF)
	8	1/4" NPT female thread adaptors on side
MK115.05-08 Q 13	8	115.05 EUBM 14 (FF)
	8	1/4" BSPT female thread adaptors on side
MK115.05-08 U 14	8	115.05 EUBM 14 (FF)
	8	9/16" UNF female thread adaptors on side

MULTICOUPLINGS
 MULTIKUPPLUNGEN

SERIE 115.05M

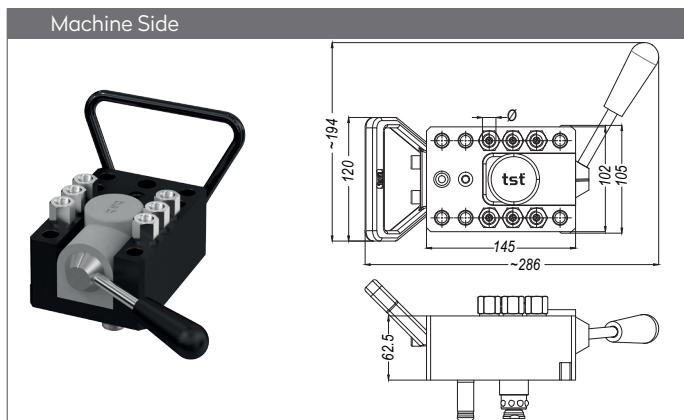
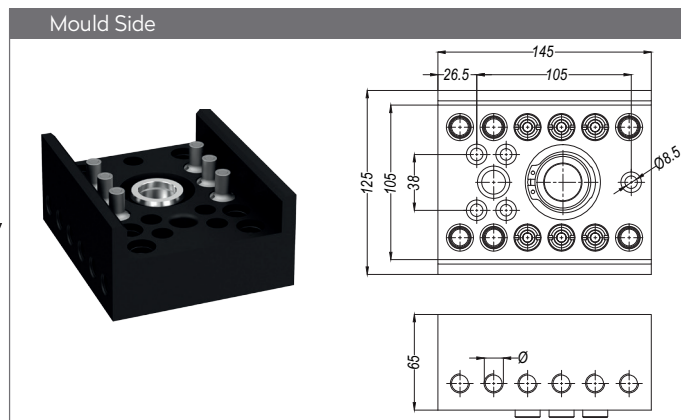
 3
 ↑
 ↓
 3

Part No.	Unit	Ø
MM115.05-00G13	-	without couplings
MM115.05-06 G 13	6	115.05 EGB 00 (FF)
	6	1/4" BSP female thread side holes empty
MM115.05-06 N 13	6	115.05 EGB 00 (FF)
	6	1/4" NPT female thread adaptors on side
MM115.05-06 Q 13	6	115.05 EGB 00 (FF)
	6	1/4" BSPT female thread adaptors on side
MM115.05-06 U 14	6	115.05 EGB 00 (FF)
	6	9/16" UNF female thread adaptors on side

Part No.	Unit	Ø
MK115.05-00G13	-	without plugs
MK115.05-06 G 13	6	115.05 EUBM 14 (FF)
	6	1/4" BSP female thread side holes empty
MK115.05-06 N 13	6	115.05 EUBM 14 (FF)
	6	1/4" NPT female thread adaptors on side
MK115.05-06 Q 13	6	115.05 EUBM 14 (FF)
	6	1/4" BSPT female thread adaptors on side
MK115.05-06 U 14	6	115.05 EUBM 14 (FF)
	6	9/16" UNF female thread adaptors on side

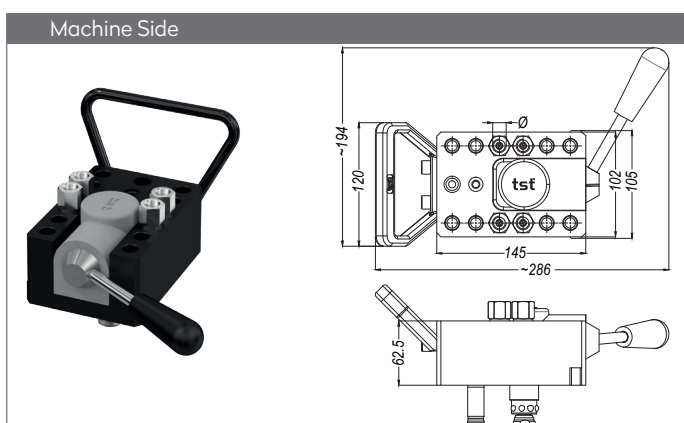
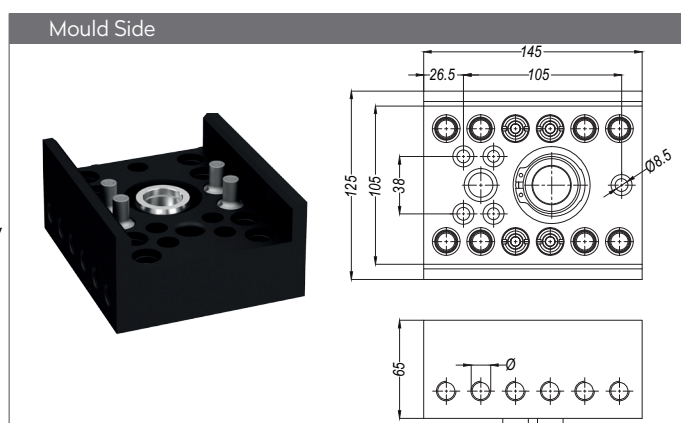
 2
 ↑
 ↓
 2

Part No.	Unit	Ø
MM115.05-00G13	-	without couplings
MM115.05-04 G 13	4	115.05 EGB 00 (FF)
	4	1/4" BSP female thread holes empty
MM115.05-04 N 13	4	115.05 EGB 00 (FF)
	4	1/4" NPT female thread adaptors
MM115.05-04 Q 13	4	115.05 EGB 00 (FF)
	4	1/4" BSPT female thread adaptors
MM115.05-04 U 14	4	115.05 EGB 00 (FF)
	4	9/16" UNF female thread adaptors

Part No.	Unit	Ø
MK115.05-00G13	-	without plugs
MK115.05-04 G 13	4	115.05 EUBM 14 (FF)
	4	1/4" BSP female thread holes empty
MK115.05-04 N 13	4	115.05 EUBM 14 (FF)
	4	1/4" NPT female thread adaptors
MK115.05-04 Q 13	4	115.05 EUBM 14 (FF)
	4	1/4" BSPT female thread adaptors
MK115.05-04 U 14	4	115.05 EUBM 14 (FF)
	4	9/16" UNF female thread adaptors

MULTICOUPLINGS
MULTIKUPPLUNGEN

SERIE 115.05M

QUICK COUPLINGS SCHNELLKUPPLUNGEN

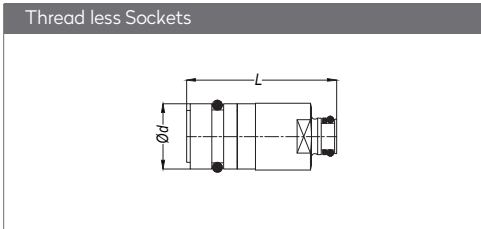

Part no.	DN	Ø	L	ØD
115.05 EGB 00	Ø 5 mm	Ring DIN-472	41.5	18.5



Part no.
115.05 ATS 00

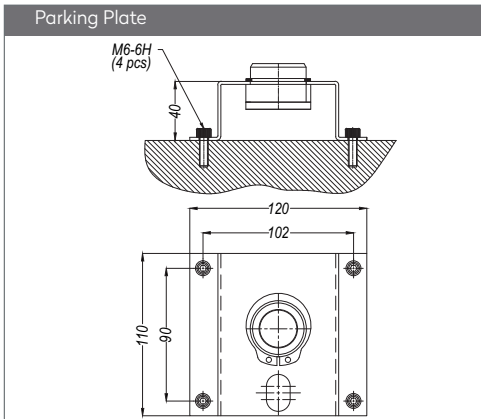

Part No.
MM115.05-12 P

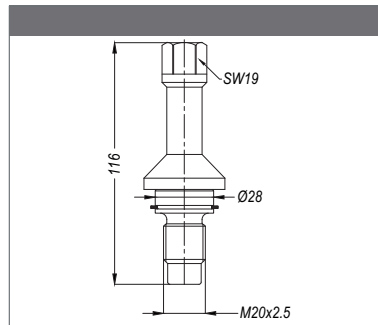
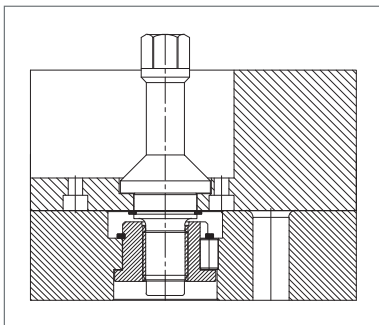

Part No.	Ø
MKV 2025 - 011	M20 x 2.5

PLUGS STECKNIPPEL

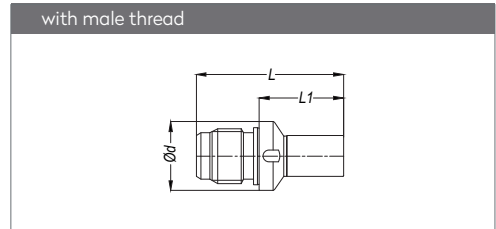

Part no.	DN	Ø	L	L1	ØD
115.05 EUBM 14	Ø 5 mm	M 14x1.5	37.5	21.5	17.5



Part no.
115.05 ATS 14

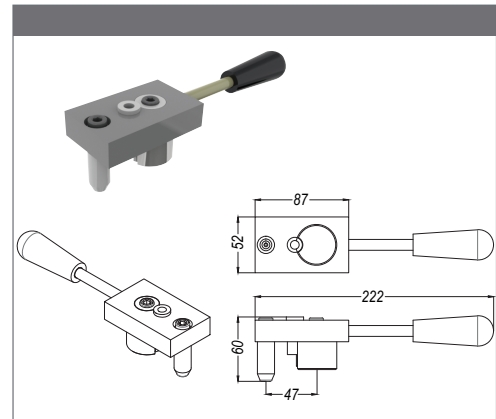

Part No.
MK115.05 VKDA 00

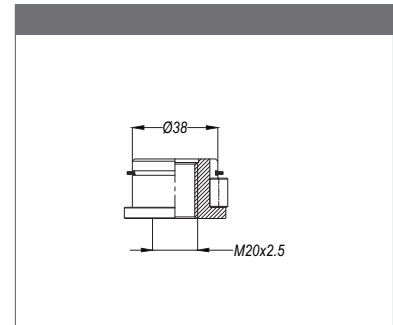

Part No.	Ø
MKS 2025 - 011	M20 x 2.5

HYDRAULIC COUPLINGS
 HYDRAULISCHE KUPPLUNGEN

SERIE 115mono

DN 3-20

Materials

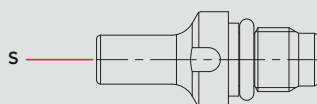
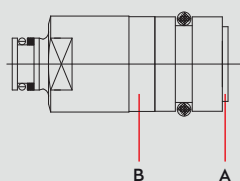

Material Code

A = AISI 303

B = AISI 303

S = AISI 420



TST 115.03 → 0 - 450 bar
 TST 115.05 → 0 - 300 bar
 TST 115.08 → 0 - 250 bar
 TST 115.12 → 0 - 160 bar
 TST 115.20 → 0 - 160 bar



-26°C to + 200°C (FPM)

Shut Off Type



Applications

- Quick mould change
- Hot runner systems

FF

DN 3-20 mm

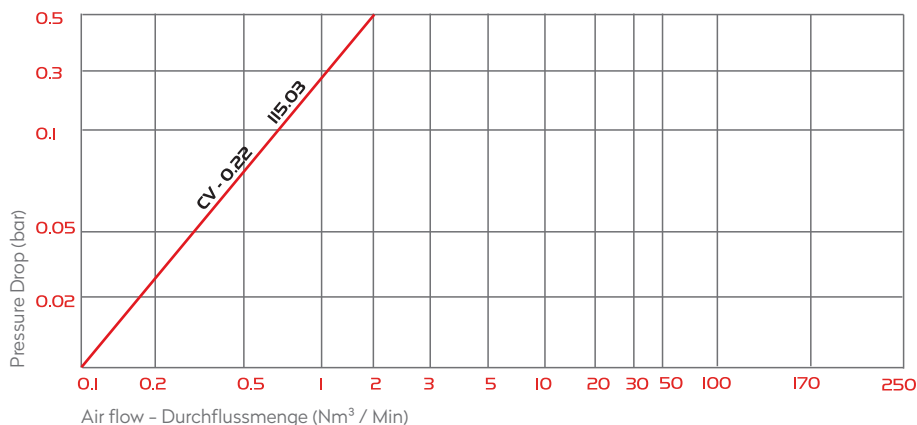

QUICK COUPLINGS SCHNELLKUPPLUNGEN PLUGS STECKNIPPEL

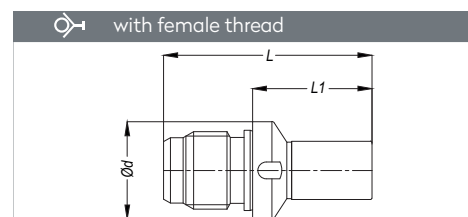
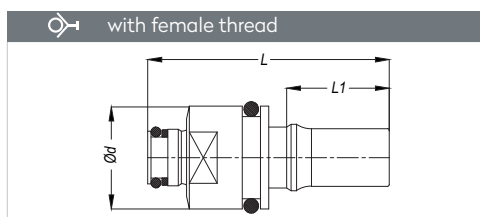
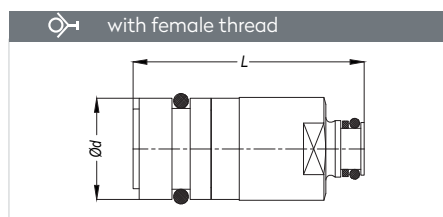

Part no.	DN	Ø	L	ØD
115.03 EGB 00	Ø 3 mm	Ring Special	32.6	13
115.05 EGB 00	Ø 5 mm	Ring DIN-472	41.5	18.5
115.08 EGB 00	Ø 8 mm	Ring DIN-472	46	23.5
115.12 EGB 00	Ø 12 mm	Ring DIN-472	67.3	31.5
115.20 EGB 00	Ø 20 mm	Ring DIN-472	82	47.9

Part no.	DN	Ø	L	L1	ØD
115.03 EUB 00	Ø 3 mm	Ring Special	32.8	13.5	13.3
115.05 EUB 00	Ø 5 mm	Ring DIN-472	43.5	18.5	18.5
115.08 EUB 00	Ø 8 mm	Ring DIN-472	49.3	21	23.5
115.12 EUB 00	Ø 12 mm	Ring DIN-472	64	29.5	31.5
115.20 EUB 00	Ø 20 mm	Ring DIN-472	82.5	42.6	45.9

Part no.	DN	Ø	L	L1	ØD
115.03 EUBM 08	Ø 3 mm	M8 x 1	27.8	16.5	12
115.05 EUBM 14	Ø 5 mm	M14 x 1.5	37.5	21.5	17.5
115.08 EUBM 18	Ø 8 mm	M18 x 1.5	43	24.5	22
115.12 EUBM 24	Ø 12 mm	M24 x 1.5	55	32	28.5
115.20 EUBM 38	Ø 20 mm	M38 x 1.5	75	47.1	46

Materials

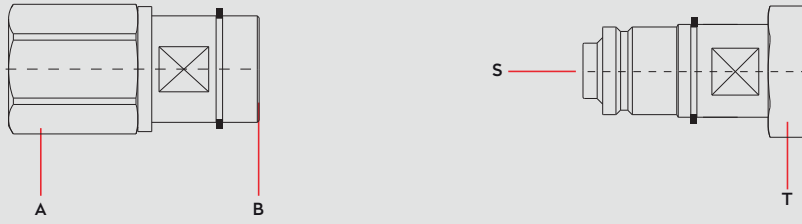

Material Code

- A = Brass
- B = Brass
- S = Brass
- T = Brass



0 - 16 bar



-26°C to + 200°C (FPM)

Shut Off Type

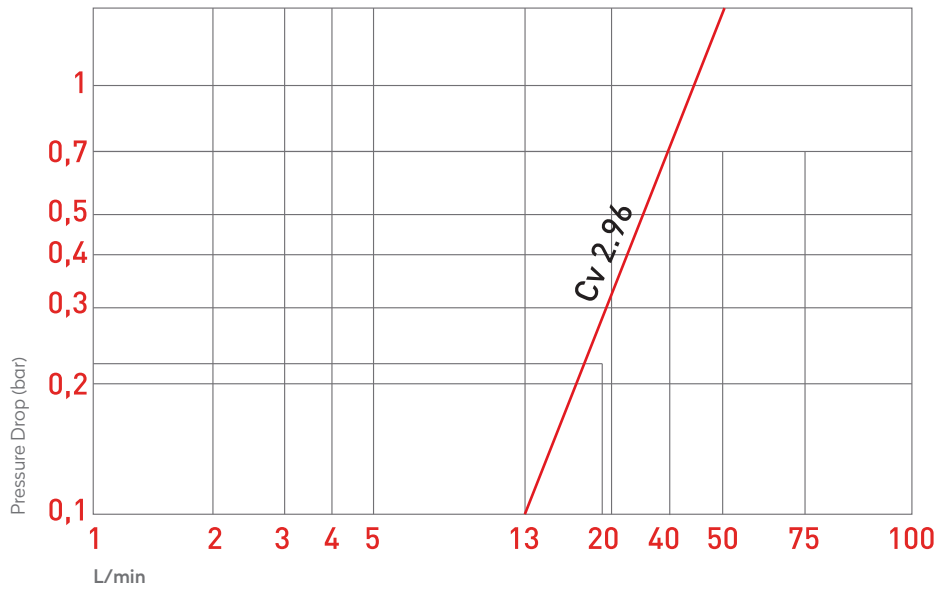
FF



COUPLING	OV 262- 01235 OV 262 - 01435 OV 178 - 01660
PLUG	OV 178 - 00605 OV 178 - 01660

Applications

- Temperature controlling

DN 9 mm

Compatible with EAS

9 ↔ 9

SERIE 150.09M

Multi Couplings Systems for quick changing of injection moulding and die cast equipments

Multikupplungensysteme für schnelles Wechseln und Verbinden der Kokillen und Spritzgußformen

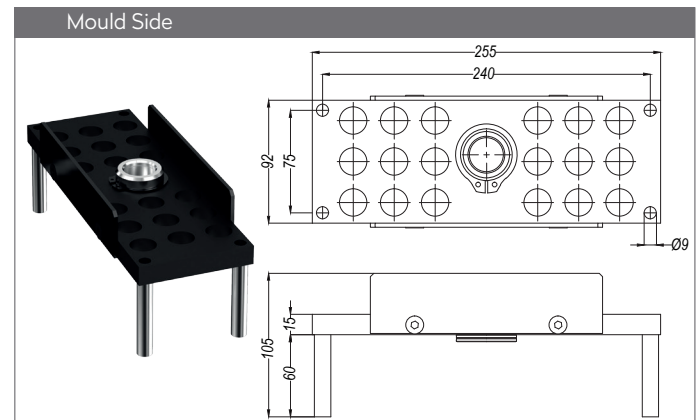
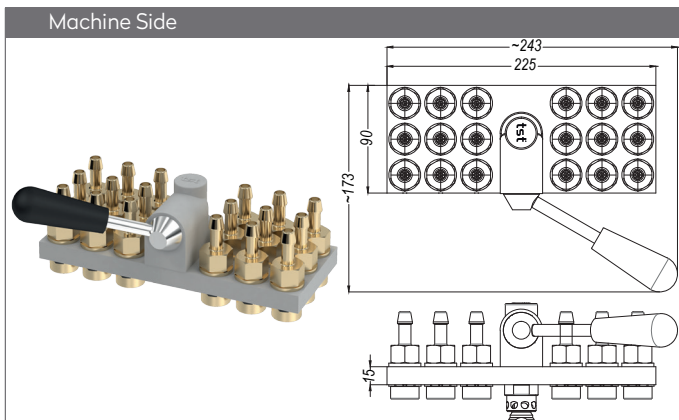

Part No.	Unit	Ø
MM150.09-18	-	without couplings
MM150.09-18 HGB 10	18	Hose tail 10 mm
MM150.09-18 HGB 13	18	Hose tail 13 mm
MM150.09-18 FGB 10	18	Push-Lock Hose tail 10 mm
MM150.09-18 FGB 13	18	Push-Lock Hose tail 13 mm
MM150.09-18 DGB 17	18	BSP female 3/8"
MM150.09-18 NGB 17	18	NPT female 3/8"

Part No.	Unit	Ø
MK150.09-18	-	without plugs
MK150.09-18 DUB 17	18	BSP female 3/8" with valve
MK150.09-18 NUB 17	18	NPT female 3/8" with valve
MK150.09-18 DU 17	18	BSP female 3/8" without valve
MK150.09-18 NU 17	18	NPT female 3/8" without valve

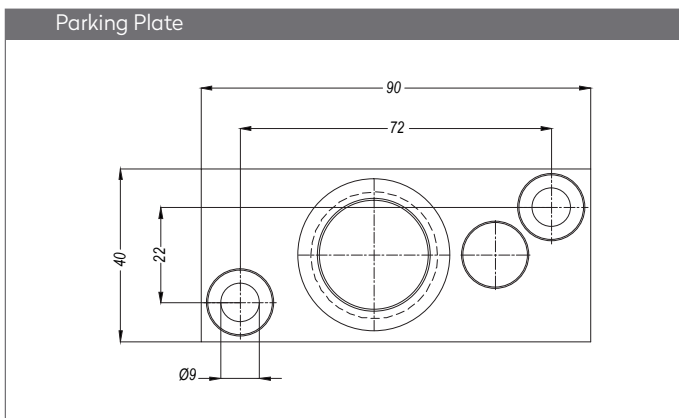

Part No.
MM150.09 P

SERIE 150.09M

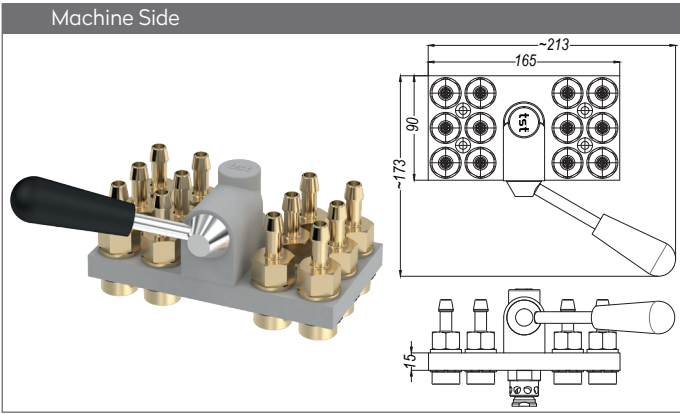

Part No.	Unit	Ø
MM150.09-12	-	without couplings
MM150.09-12 HGB 10	12	Hose tail 10 mm
MM150.09-12 HGB 13	12	Hose tail 13 mm
MM150.09-12 FGB 10	12	Push-Lock Hose tail 10 mm
MM150.09-12 FGB 13	12	Push-Lock Hose tail 13 mm
MM150.09-12 DGB 17	12	BSP female 3/8"
MM150.09-12 NGB 17	12	NPT female 3/8"

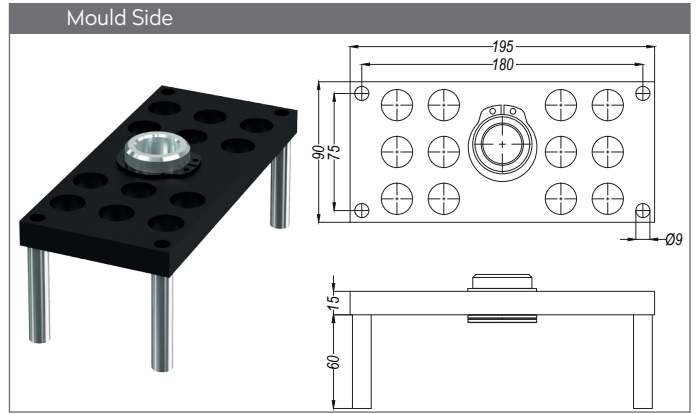

Part No.	Unit	Ø
MK150.09-12	-	without plugs
MK150.09-12 DUB 17	12	BSP female 3/8" with valve
MK150.09-12 NUB 17	12	NPT female 3/8" with valve
MK150.09-12 DU 17	12	BSP female 3/8" without valve
MK150.09-12 NU 17	12	NPT female 3/8" without valve

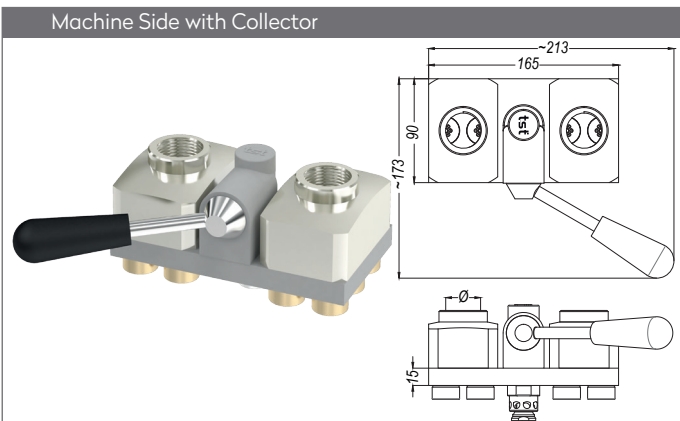

Part No.	Unit	Ø
MM150.09-12C	12	BSP female 1"
MM150.09-12CN	12	NPT female 1"

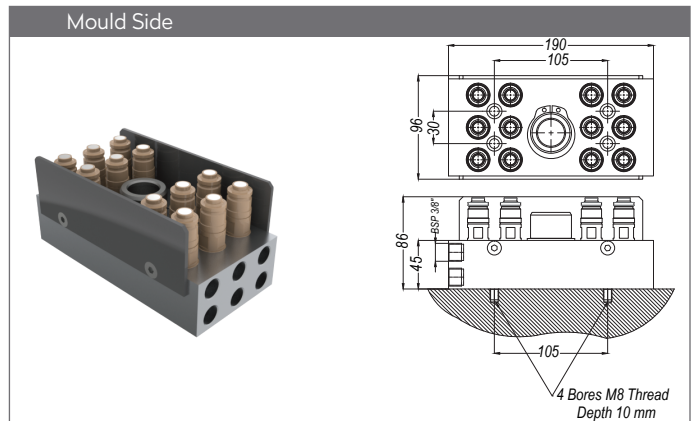

Part No.	Unit	Ø
MK150.09 - 12V	12	BSP 3/8"

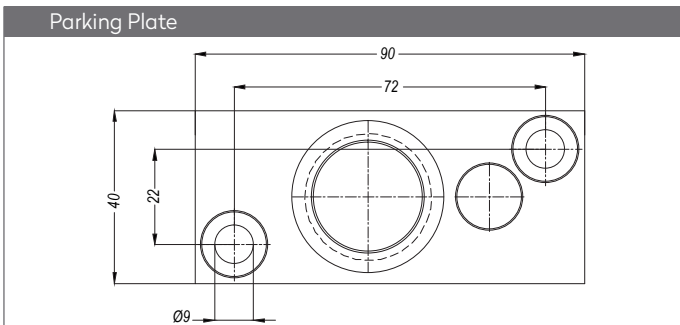

Part No.
MM150.09 P

5 ↔ 5

SERIE 150.09M

Multi Couplings Systems for quick changing of injection moulding and die cast equipments

Multikupplungensysteme für schnelles Wechseln und Verbinden der Kokillen und Spritzgußformen

Machine Side

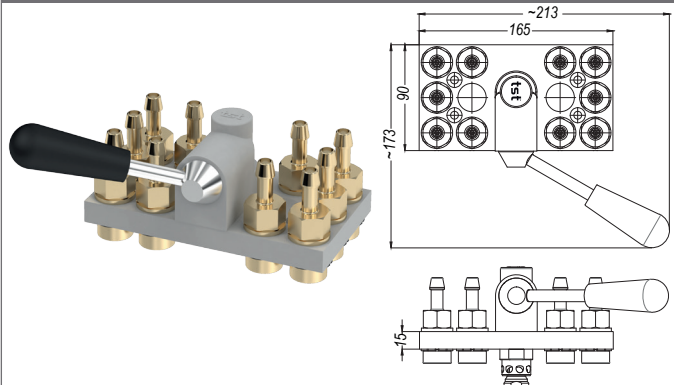

Mould Side

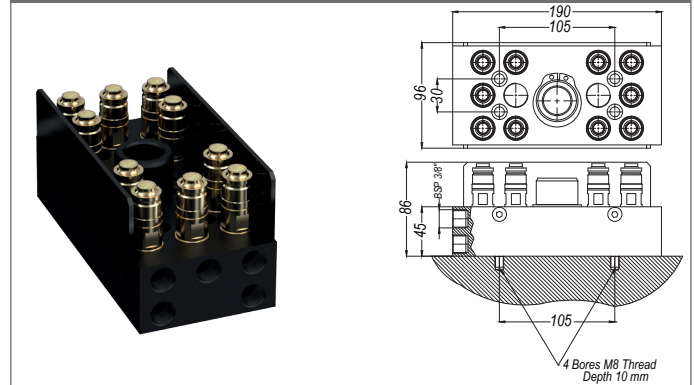

Part No.	Unit	Ø
MM150.09-12	-	without couplings
MM150.09-10 HGB 10	10	Hose tail 10 mm
MM150.09-10 HGB 13	10	Hose tail 13 mm
MM150.09-10 FGB 10	10	Push-Lock Hose tail 10 mm
MM150.09-10 FGB 13	10	Push-Lock Hose tail 13 mm
MM150.09-10 DGB 17	10	BSP female 3/8"
MM150.09-10 NGB 17	10	NPT female 3/8"

Part No.	Unit	Ø
MK150.09-10	10	Metric male M22x1 without valve
MK150.09-10V	10	Metric male M22x1 with valve

Parking Plate

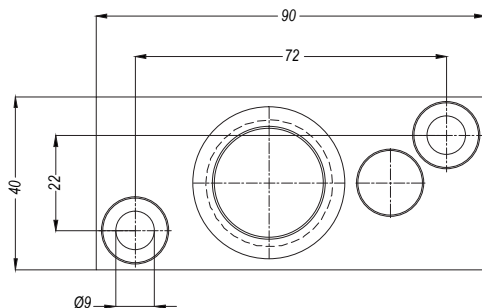

Part No.

MM150.09 P

SERIE 150.09M

Multi Couplings Systems for quick changing of injection moulding and die cast equipments

Multikupplungensysteme für schnelles Wechseln und Verbinden der Kokillen und Spritzgußformen

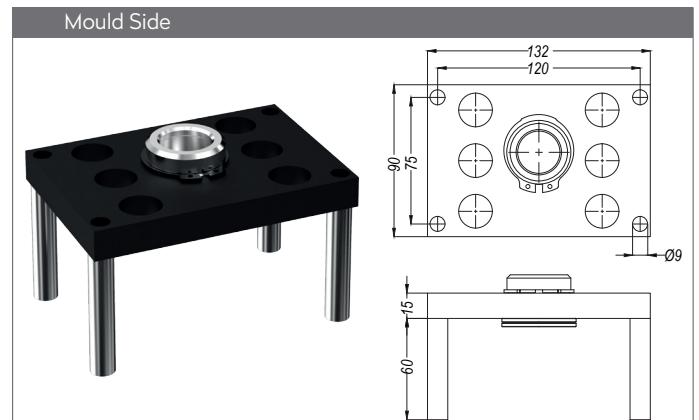
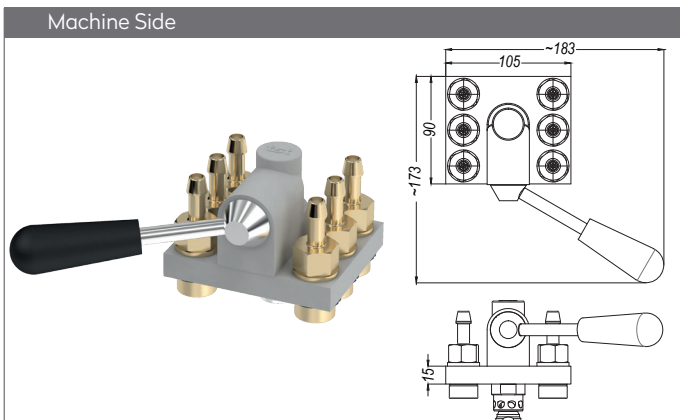

Part No.	Unit	Ø
MM150.09-06	-	without couplings
MM150.09-06 HGB 10	6	Hose tail 10 mm
MM150.09-06 HGB 13	6	Hose tail 13 mm
MM150.09-06 FGB 10	6	Push-Lock Hose tail 10 mm
MM150.09-06 FGB 13	6	Push-Lock Hose tail 13 mm
MM150.09-06 DGB 17	6	BSP female 3/8"
MM150.09-06 NGB 17	6	NPT female 3/8"

Part No.	Unit	Ø
MK150.09-06	-	without plugs
MK150.09-06 DUB 17	6	BSP female 3/8" with valve
MK150.09-06 NUB 17	6	NPT female 3/8" with valve
MK150.09-06 DU 17	6	BSP female 3/8" without valve
MK150.09-06 NU 17	6	NPT female 3/8" without valve

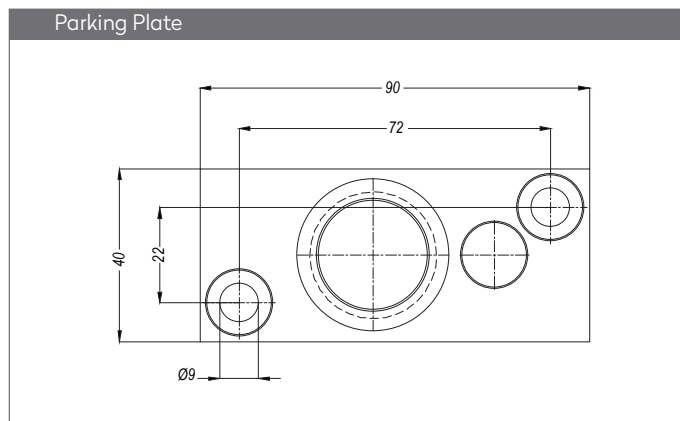

Part No.
MM150.09 P

MULTICOUPLINGS
 MULTIKUPPLUNGEN

SERIE 150.09M

QUICK COUPLINGS SCHNELLKUPPLUNGEN

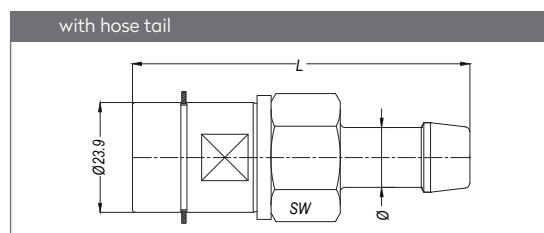

With Valve	Without Valve	SW	Ø	L
MM150.09 HGB 06	MM150.09 HGF 06	24	6	73
MM150.09 HGB 13	MM150.09 HGF 13	24	13	73

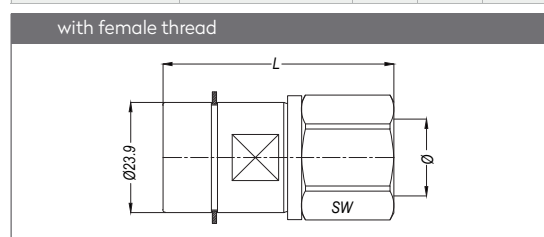

With Valve	Without Valve	SW	Ø	L
MM150.09 DGB 17	MM150.09 DGF 17	24	BSP 3/8"	50
MM150.09 NGB 17	MM150.09 NGF 17	24	NPT 3/8"	55

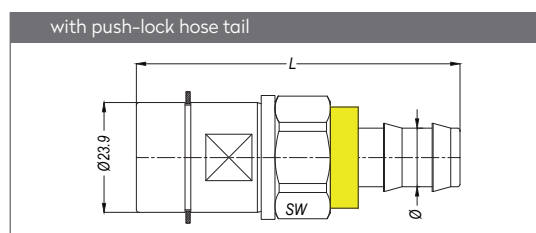

With Valve	Without Valve	SW	Ø	L
MM150.09 FGB 09	MM150.09 FGF 09	24	9	70
MM150.09 FGB 13	MM150.09 FGF 13	24	13	70

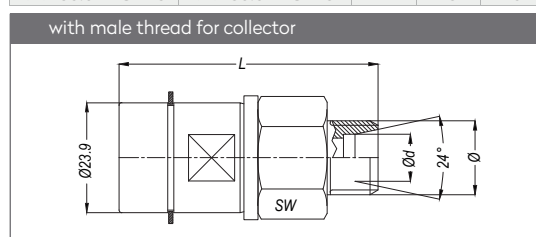

With Valve	Without Valve	Ø	Ød	SW	L
MM109 EGBM 16-10	-	M16x1.5	10.2	24	56
MM109 EGBM 18-12	-	M18x1.5	10.2	24	57

PLUGS STECKNIPPEL

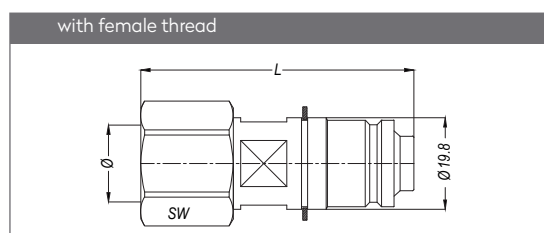

With Valve	Without Valve	SW	Ø	L
MK150.09 DUB 17	MK150.09 DUF 17	24	BSP 3/8"	59.1
MK150.09 NUB 17	MK150.09 NUF 17	24	NPT 3/8"	64.1

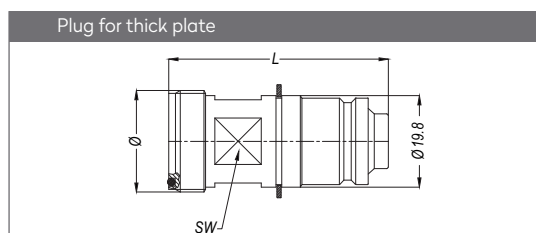

With Valve	Without Valve	SW	Ø	L
150.09 EUBM 22x1	-	18	M22x1	47.5

ACCESSORIES ZUBEHÖR

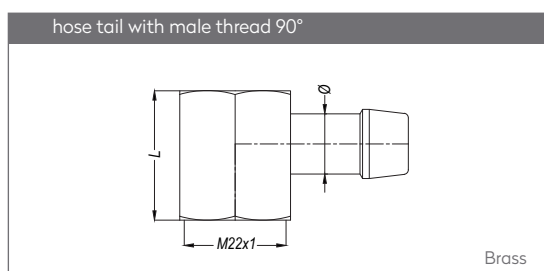

Part No.	L	Ø
150.09 DB 13 x 28	28	13
150.09 DB 13 x 52	52	13

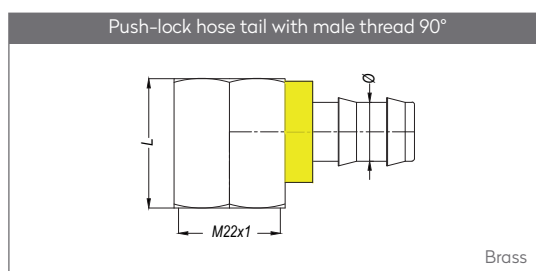

Part No.	L	Ø
150.09 DF 13 x 28	28	12.8
150.09 DF 13 x 52	52	12.8

Materials

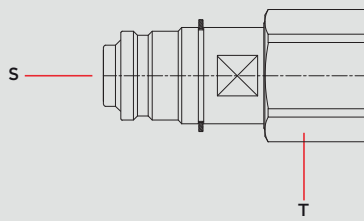
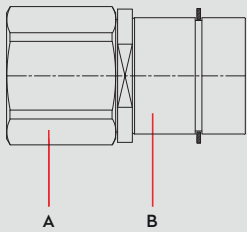

Material Code

A = Brass

B = Brass

S = Brass

T = Brass



0 - 16 bar



-26°C to + 200°C (FPM)

Shut Off
Type



COUPLING
PLUG

OV 262- 01715
OV 262 - 01510
OV 178 - 02035
07210VC00V
OV 178 - 00925
OV 178 - 02035

DN

12 mm

FF

Applications

- Temperature controlling

Compatible with

EAS

MULTICOUPLINGS

MULTIKUPPLUNGEN

6 ↔ 6

SERIE 150.12M

Multi Couplings Systems for quick changing of injection moulding and die cast equipments

Multikupplungensysteme für schnelles Wechseln und Verbinden der Kokillen und Spritzgußformen

Machine Side

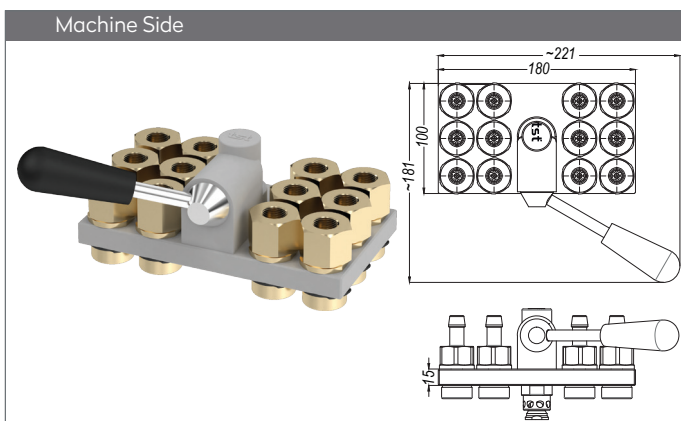

Mould Side

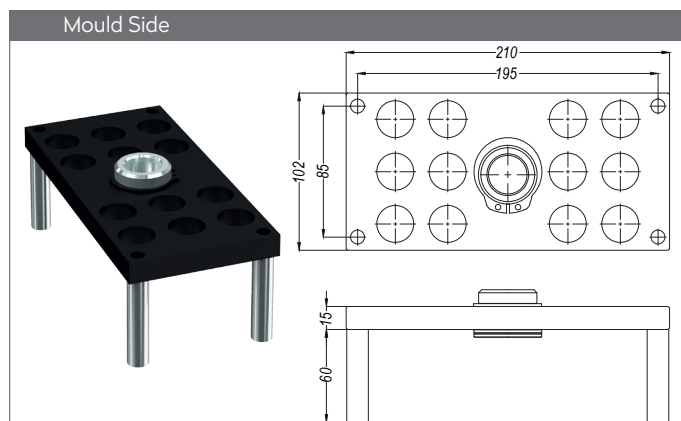

Part No.	Unit	Ø
MM150.12-12	-	without couplings
MM150.12-12 HGB 10	12	Hose tail 10 mm
MM150.12-12 HGB 13	12	Hose tail 13 mm
MM150.12-12 FGB 10	12	Push-Lock Hose tail 10 mm
MM150.12-12 FGB 13	12	Push-Lock Hose tail 13 mm
MM150.12-12 DGB 17	12	BSP female 3/8"
MM150.12-12 NGB 17	12	NPT female 3/8"

Part No.	Unit	Ø
MK150.12-12	-	without plugs
MK150.12-12 DUB 17	12	BSP female 3/8" with valve
MK150.12-12 NUB 17	12	NPT female 3/8" with valve
MK150.12-12 DU 17	12	BSP female 3/8" without valve
MK150.12-12 NU 17	12	NPT female 3/8" without valve

Mould Side

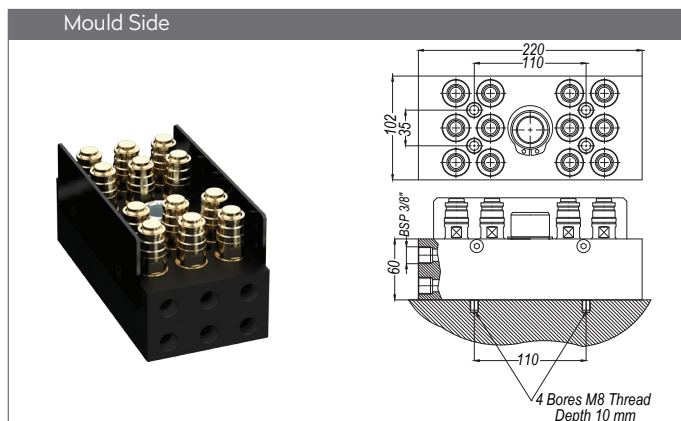

Parking Plate

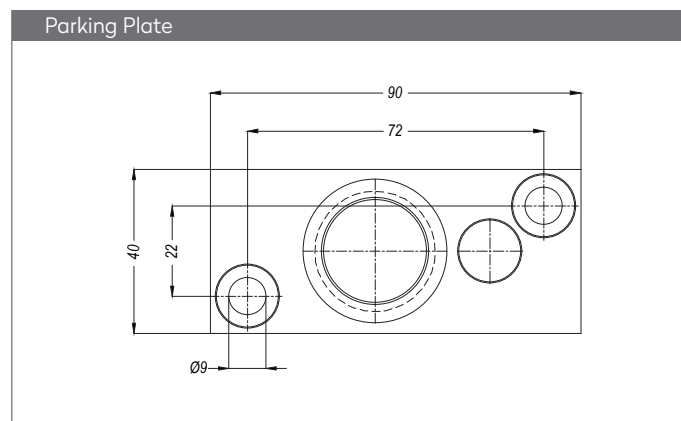

Part No.	Unit	Ø
MK150.12-12V	12	Metric male M27x1

Part No.
MM150.09 P

MULTICOUPLINGS
MULTIKUPPLUNGEN

SERIE 150.12M

QUICK COUPLINGS SCHNELLKUPPLUNGEN

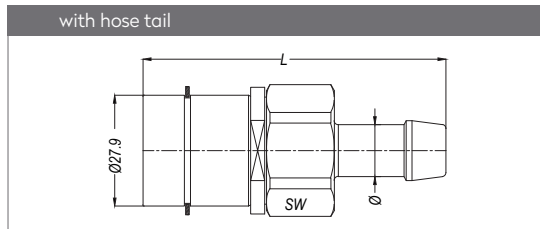

↻	←	SW	Ø	L
With Valve	Without Valve			
150.12 HGB 12	150.12 HGF 12	30	12	76
150.12 HGB 13	150.12 HGF 13	30	13	76
150.12 HGB 16	150.12 HGF 16	30	16	76
150.12 HGB 19	150.12 HGF 19	30	19	76

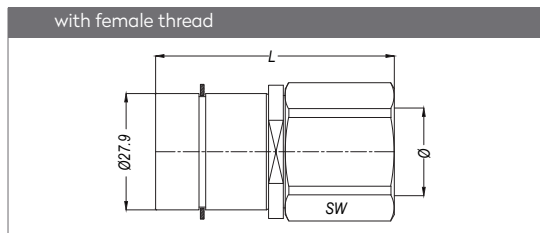

↻	←	SW	Ø	L
With Valve	Without Valve			
150.12 DGB 21	150.12 DGF 21	30	BSP 1/2"	57
150.12 NGB 21	150.12 NGF 21	30	NPT 1/2"	62

PLUGS STECKNIPPEL

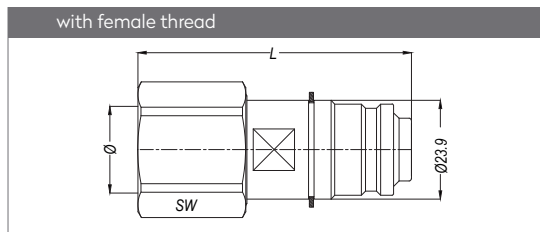

↻	←	SW	Ø	L
With Valve	Without Valve			
150.12 DUB 21	150.12 DUF 21	30	BSP 1/2"	66
150.12 NUB 21	150.12 NUF 21	30	NPT 1/2"	71

ACCESSORIES ZUBEHÖR

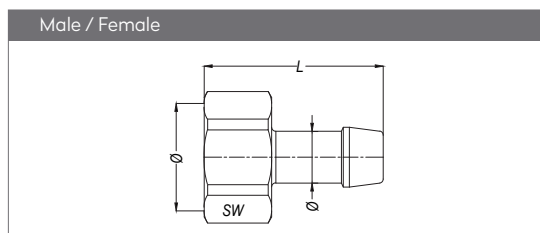

Part No.	Ød	SW	Ø	L
150.12 FA 10	10	30	M27x1	41
150.12 FA 16	16	30	M27x1	55
150.12 FA 19	19	30	M27x1	55

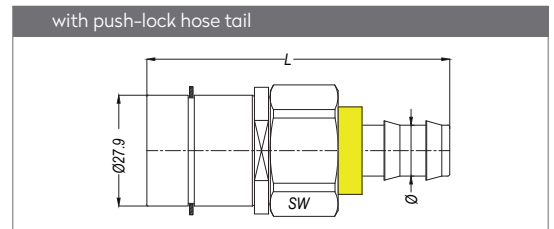

↻	←	SW	Ø	L
With Valve	Without Valve			
150.12 FGB 16	150.12 FGF 16	30	16	76
150.12 FGB 19	150.12 FGF 19	30	19	76

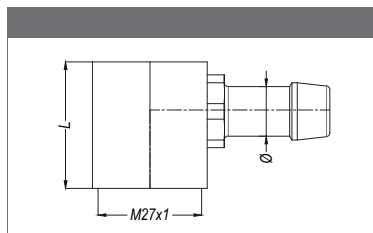

Part No.	Ød	L
150.12 DB 13x33	13	33
150.12 DB 13x57	13	57
150.12 DB 16x33	16	33
150.12 DB 16x57	16	57

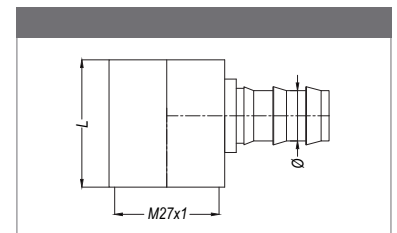

Part No.	Ød	L
150.12 DF 13x33	13	33
150.12 DF 13x57	13	57
150.12 DF 16x33	16	33
150.12 DF 16x57	16	57

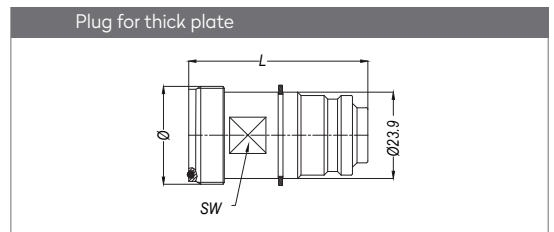

↻	←	SW	Ø	L
With Valve	Without Valve			
150.12 EUBM27x1	-	22	M27x1	49.5

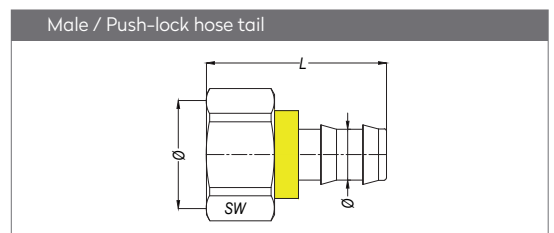

Part No.	Ød	SW	Ø	L
150.12 HA 12	12	30	M27x1	45
150.12 HA 13	13	30	M27x1	45
150.12 HA 16	16	30	M27x1	45
150.12 HA 17	17	30	M27x1	45
150.12 HA 19	19	30	M27x1	45

DN10

MULTICOUPLINGS
MULTIKUPPLUNGEN

SERIE 152.10M

Materials

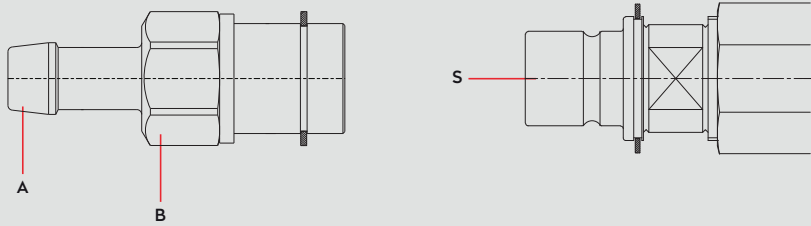

Material Code

A = Brass
B = Brass
S = AISI 303



0 - 16 bar



-26°C to + 200°C (FPM)

Shut Off Type



COUPLING
OV 200 - 01700
OV 200 - 00600
OV 157 - 02100
PLUG
OV 200 - 00600
OV 178 - 01875
OV 157 - 02100

FF

DN 10 mm

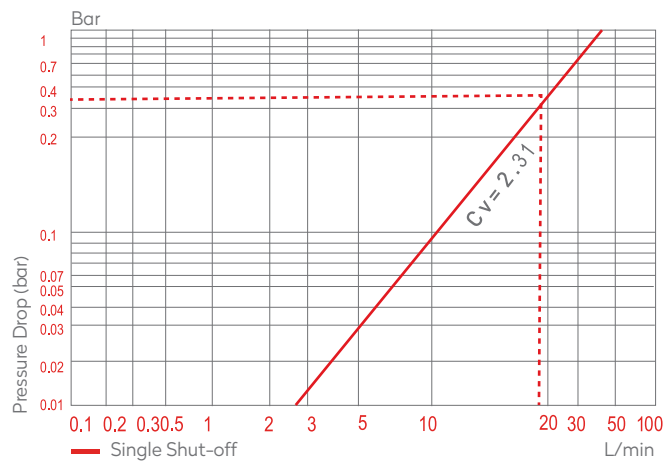

Options

EPDM

COLOURED
PLATE

Applications

- Temperature controlling

Compatible with

TST Design

12 ⇄ 12

SERIE 152.10M

Multi Couplings Systems for quick changing of injection moulding and die cast equipments

Multikupplungensysteme für schnelles Wechseln und Verbinden der Kokillen und Spritzgußformen

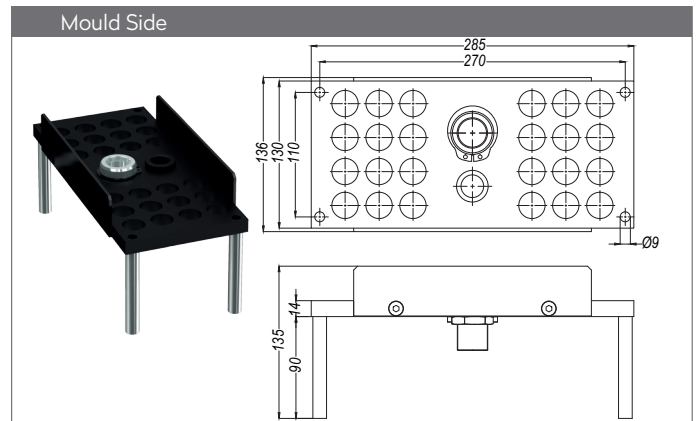
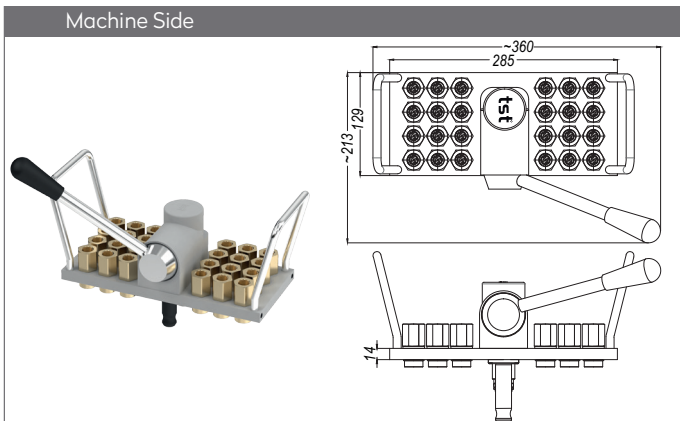

Part No.	Unit	Ø
MM152.10-24	-	without couplings
MM152.10-24 HGB 10	24	Hose tail 10 mm
MM152.10-24 HGB 13	24	Hose tail 13 mm
MM152.10-24 FGB 10	24	Push-Lock Hose tail 10 mm
MM152.10-24 FGB 13	24	Push-Lock Hose tail 13 mm
MM152.10-24 DGB 17	24	BSP female 3/8"
MM152.10-24 NGB 17	24	NPT female 3/8"

Part No.	Unit	Ø
MK152.10-24	-	without plugs
MK152.10-24 DUB 17	24	BSP female 3/8" with valve
MK152.10-24 NUB 17	24	NPT female 3/8" with valve
MK152.10-24 DU 17	24	BSP female 3/8" without valve
MK152.10-24 NU 17	24	NPT female 3/8" without valve

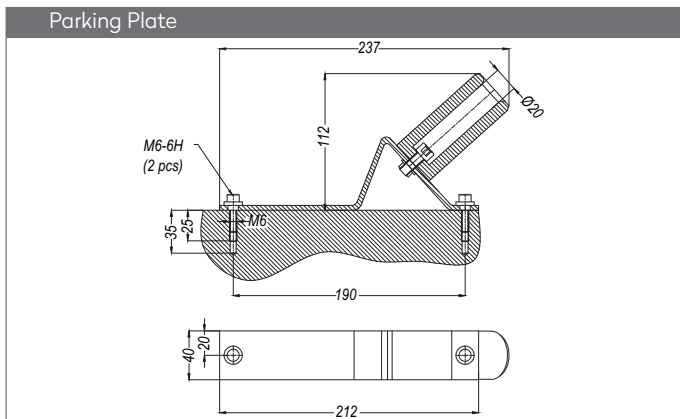

Part No.
MM108.06 P

MULTICOUPLINGS

MULTIKUPPLUNGEN

10 ↔ 10

SERIE 152.10M

Multi Couplings Systems for quick changing of injection moulding and die cast equipments

Multikupplungensysteme für schnelles Wechseln und Verbinden der Kokillen und Spritzgußformen

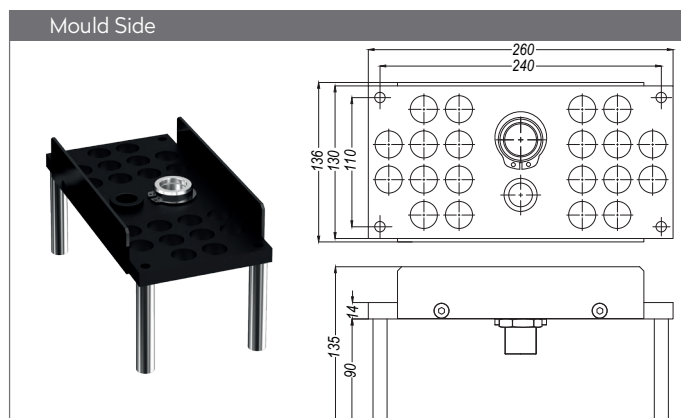
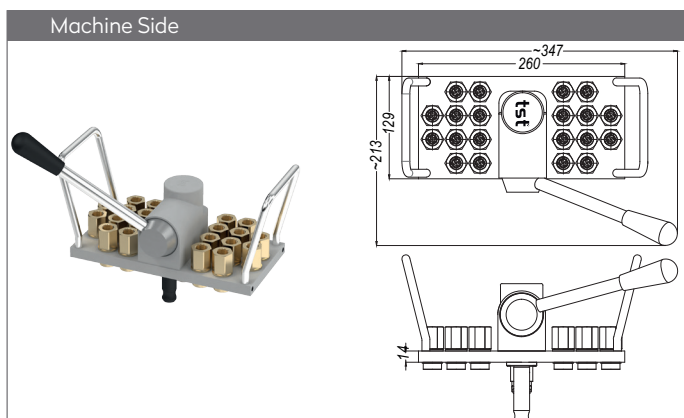

Part No.	Unit	Ø
MM152.10-20	-	without couplings
MM152.10-20 HGB 10	20	Hose tail 10 mm
MM152.10-20 HGB 13	20	Hose tail 13 mm
MM152.10-20 FGB 10	20	Push-Lock Hose tail 10 mm
MM152.10-20 FGB 13	20	Push-Lock Hose tail 13 mm
MM152.10-20 DGB 17	20	BSP female 3/8"
MM152.10-20 NGB 17	20	NPT female 3/8"

Part No.	Unit	Ø
MK152.10-20	-	without plugs
MK152.10-20 DUB 17	20	BSP female 3/8" with valve
MK152.10-20 NUB 17	20	NPT female 3/8" with valve
MK152.10-20 DU 17	20	BSP female 3/8" without valve
MK152.10-20 NU 17	20	NPT female 3/8" without valve

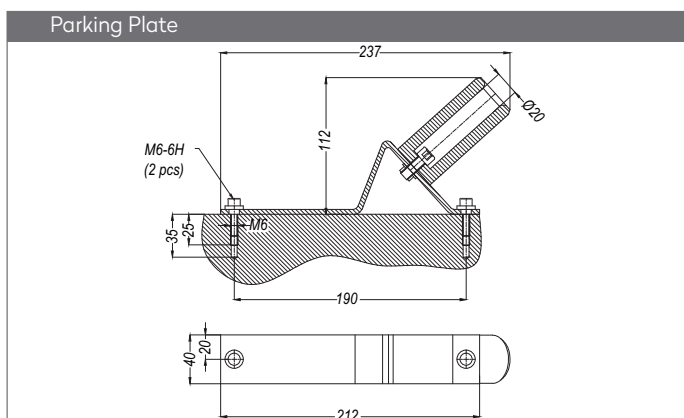

Part No.
MM108.06 P



SERIE 152.10M

Multi Couplings Systems for quick changing of injection moulding and die cast equipments

Multikupplungensysteme für schnelles Wechseln und Verbinden der Kokillen und Spritzgußformen

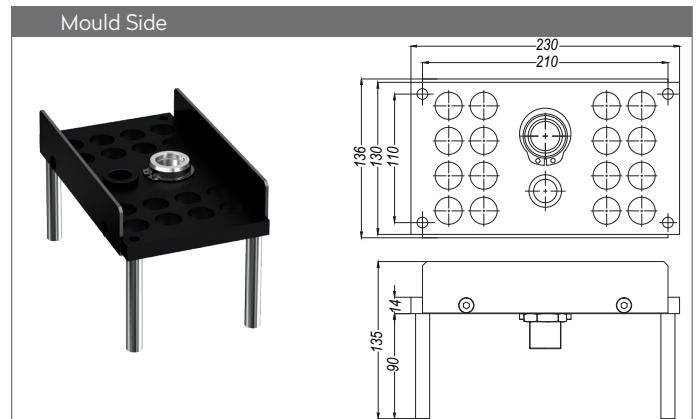
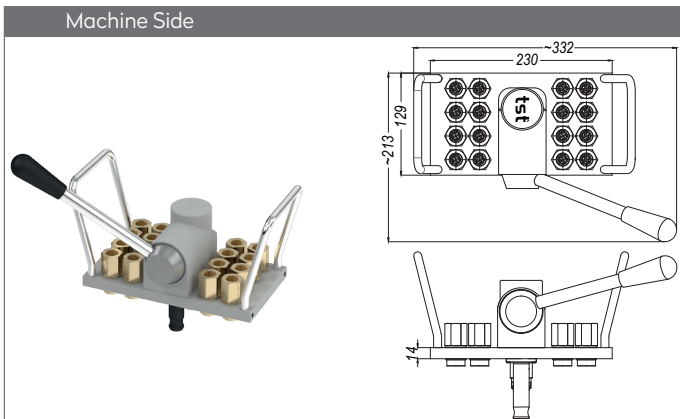

Part No.	Unit	Ø
MM152.10-16	-	without couplings
MM152.10-16 HGB 10	16	Hose tail 10 mm
MM152.10-16 HGB 13	16	Hose tail 13 mm
MM152.10-16 FGB 10	16	Push-Lock Hose tail 10 mm
MM152.10-16 FGB 13	16	Push-Lock Hose tail 13 mm
MM152.10-16 DGB 17	16	BSP female 3/8"
MM152.10-16 NGB 17	16	NPT female 3/8"

Part No.	Unit	Ø
MK152.10-16	-	without plugs
MK152.10-16 DUB 17	16	BSP female 3/8" with valve
MK152.10-16 NUB 17	16	NPT female 3/8" with valve
MK152.10-16 DU 17	16	BSP female 3/8" without valve
MK152.10-16 NU 17	16	NPT female 3/8" without valve

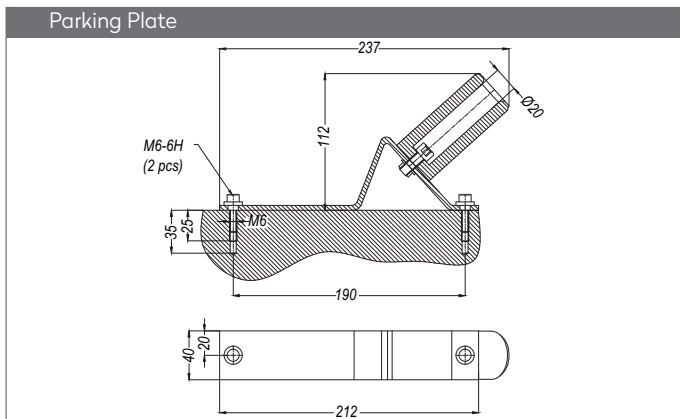

Part No.
MM108.06 P

MULTICOUPLINGS

MULTIKUPPLUNGEN

6 ↔ 6

SERIE 152.10M

Multi Couplings Systems for quick changing of injection moulding and die cast equipments

Multikupplungensysteme für schnelles Wechseln und Verbinden der Kokillen und Spritzgußformen

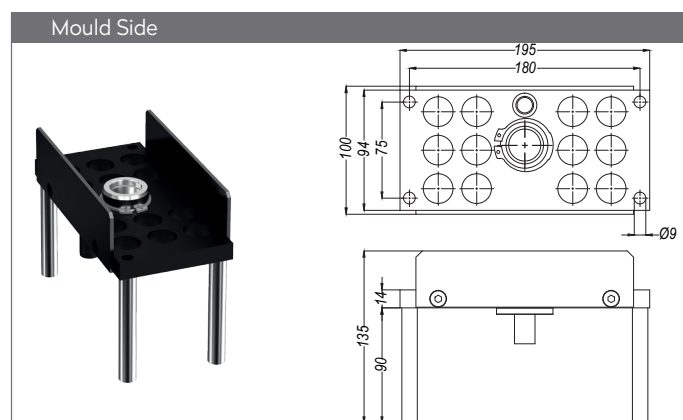
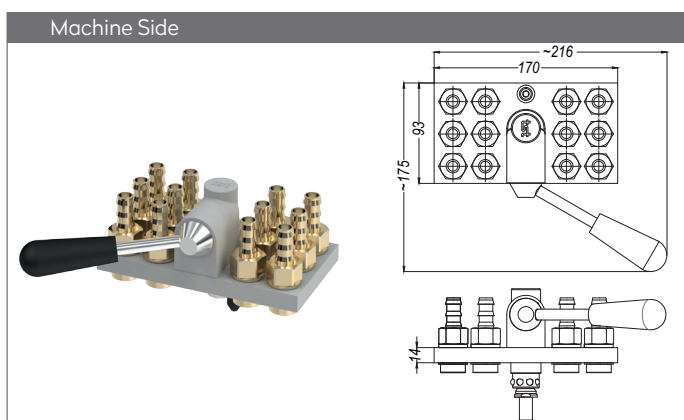

Part No.	Unit	Ø
MM152.10-12	-	without couplings
MM152.10-12 HGB 10	12	Hose tail 10 mm
MM152.10-12 HGB 13	12	Hose tail 13 mm
MM152.10-12 FGB 10	12	Push-Lock Hose tail 10 mm
MM152.10-12 FGB 13	12	Push-Lock Hose tail 13 mm
MM152.10-12 DGB 17	12	BSP female 3/8"
MM152.10-12 NGB 17	12	NPT female 3/8"

Part No.	Unit	Ø
MK152.10-12	-	without plugs
MK152.10-12 DUB 17	12	BSP female 3/8" with valve
MK152.10-12 NUB 17	12	NPT female 3/8" with valve
MK152.10-12 DU 17	12	BSP female 3/8" without valve
MK152.10-12 NU 17	12	NPT female 3/8" without valve

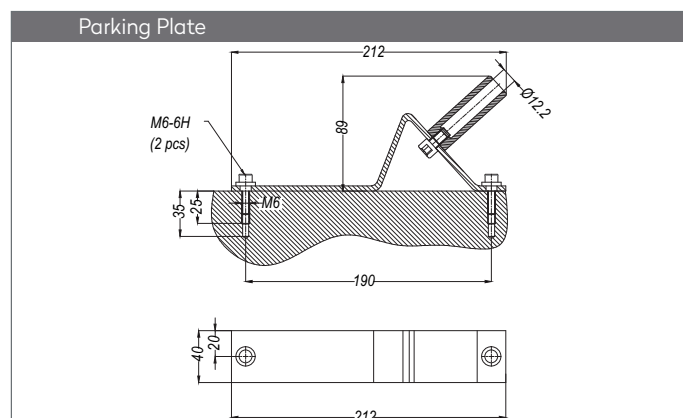
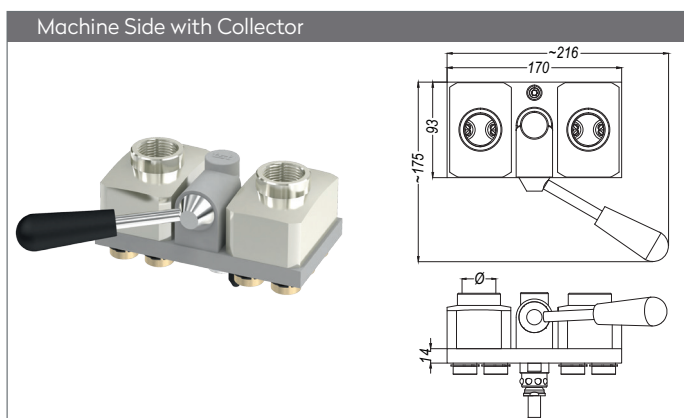

Part No.	Unit	Ø
MM152.10-12C	12	BSP female 1"
MM152.10-12CN	12	NPT female 1"

Part No.
MM152.10 P

SERIE 152.10M

Multi Couplings Systems for quick changing of injection moulding and die cast equipments

Multikupplungensysteme für schnelles Wechseln und Verbinden der Kokillen und Spritzgußformen

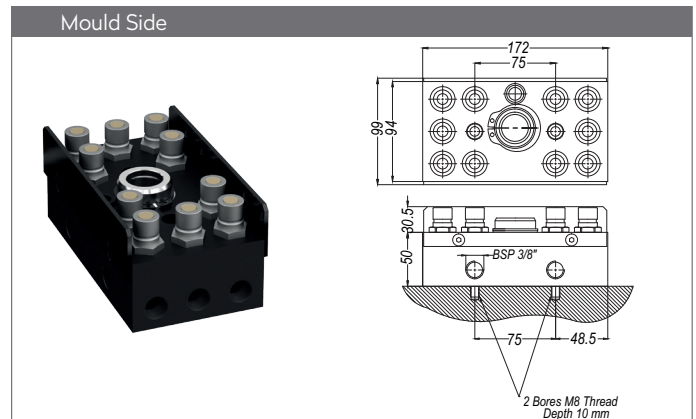
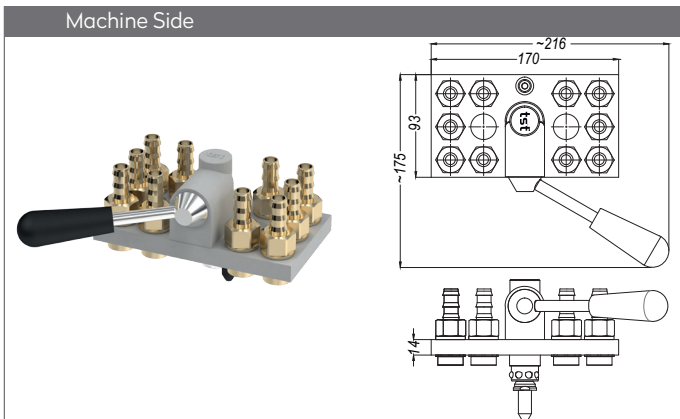

Part No.	Unit	Ø
MM152.10-12	-	without couplings
MM152.10-10 HGB 10	10	Hose tail 10 mm
MM152.10-10 HGB 12	10	Hose tail 12 mm
MM152.10-10 FGB 10	10	Push-Lock Hose tail 10 mm
MM152.10-10 FGB 13	10	Push-Lock Hose tail 13 mm
MM152.10-10 DGB 17	10	BSP female 3/8"
MM152.10-10 NGB 17	10	NPT female 3/8"

Part No.	Unit	Ø
MK152.10-10	10	BSP male 1/2" without valve
MK152.10-10 V	10	BSP male 1/2" with valve

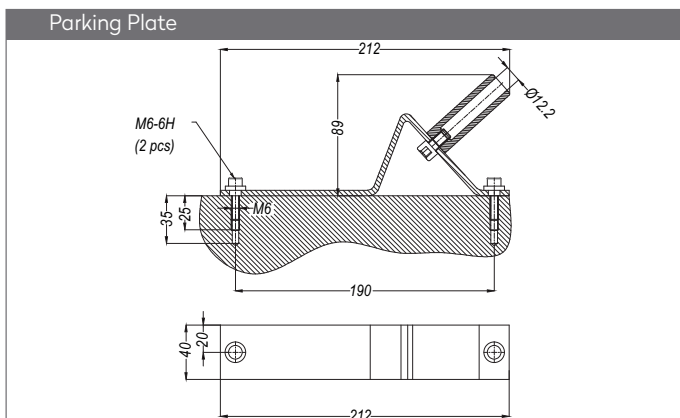

Part No.
MM152.10 P

4 ↔ 4

SERIE 152.10M

Multi Couplings Systems for quick changing of injection moulding and die cast equipments

Multikupplungensysteme für schnelles Wechseln und Verbinden der Kokillen und Spritzgußformen

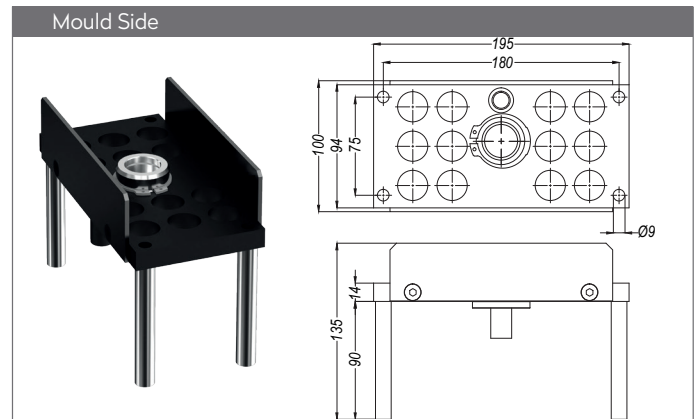
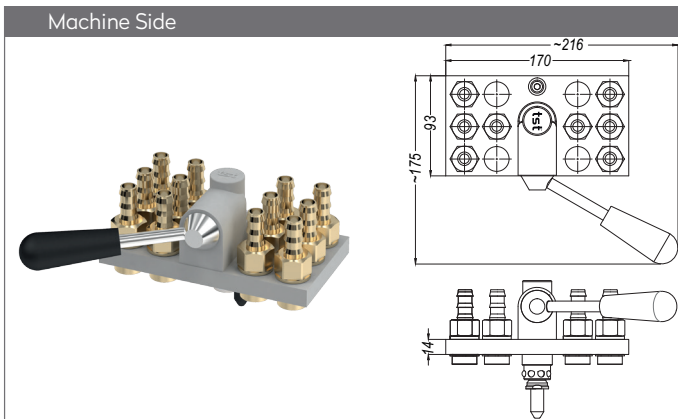

Part No.	Unit	Ø
MM152.10-12	-	without couplings
MM152.10-08 HGB 10	8	Hose tail 10 mm
MM152.10-08 HGB 12	8	Hose tail 12 mm
MM152.10-08 FGB 10	8	Push-Lock Hose tail 10 mm
MM152.10-08 FGB 13	8	Push-Lock Hose tail 13 mm
MM152.10-08 DGB 17	8	BSP female 3/8"
MM152.10-08 NGB 17	8	NPT female 3/8"

Part No.	Unit	Ø
MK152.10-12	-	without plugs
MK152.10-08 DUB 17	8	BSP female 3/8" with valve
MK152.10-08 NUB 17	8	NPT female 3/8" with valve
MK152.10-08 DU 17	8	BSP female 3/8" without valve
MK152.10-08 NU 17	8	NPT female 3/8" without valve

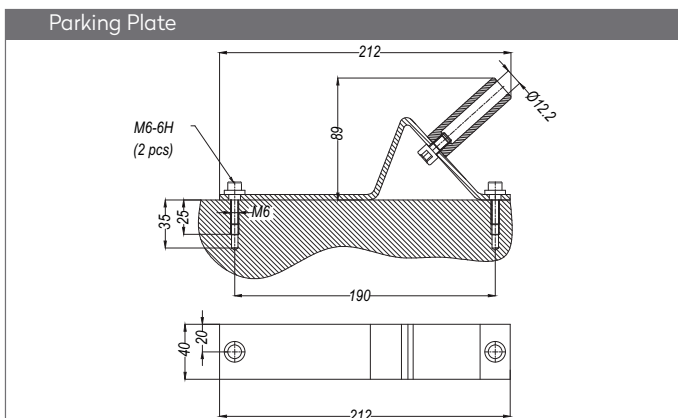

Part No.
MM152.10 P

SERIE 152.10M

Multi Couplings Systems for quick changing of injection moulding and die cast equipments

Multikupplungensysteme für schnelles Wechseln und Verbinden der Kokillen und Spritzgußformen

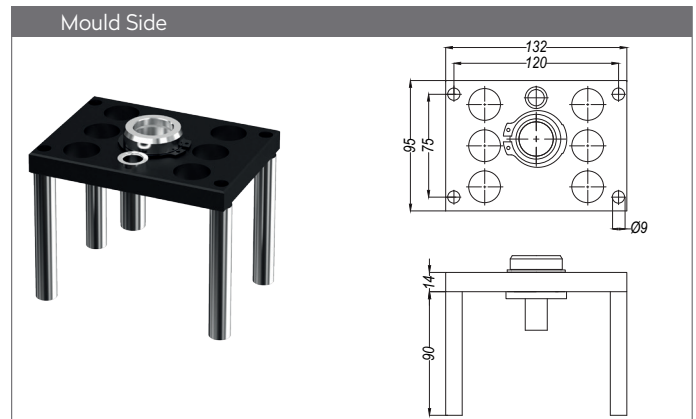
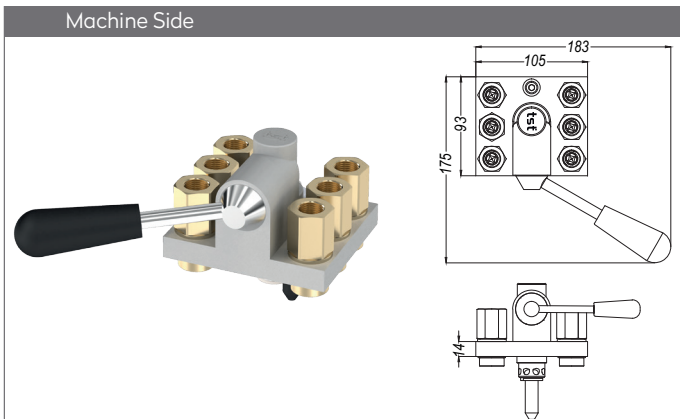

Part No.	Unit	Ø
MM152.10-06	-	without couplings
MM152.10-06 HGB 10	6	Hose tail 10 mm
MM152.10-06 HGB 12	6	Hose tail 12 mm
MM152.10-06 FGB 10	6	Push-Lock Hose tail 10 mm
MM152.10-06 FGB 13	6	Push-Lock Hose tail 13 mm
MM152.10-06 DGB 17	6	BSP female 3/8"
MM152.10-06 NGB 17	6	NPT female 3/8"

Part No.	Unit	Ø
MK152.10-06	-	without plugs
MK152.10-06 DUB 17	6	BSP female 3/8" with valve
MK152.10-06 NUB 17	6	NPT female 3/8" with valve
MK152.10-06 DU 17	6	BSP female 3/8" without valve
MK152.10-06 NU 17	6	NPT female 3/8" without valve

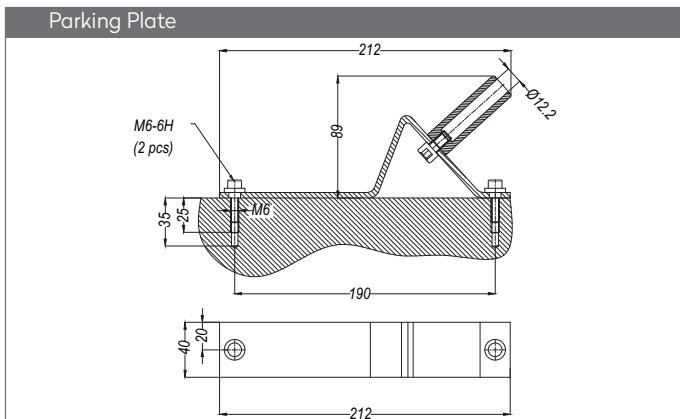

Part No.
MM152.10 P

MULTICOUPLINGS
 MULTIKUPPLUNGEN

SERIE 152.10M

QUICK COUPLINGS SCHNELLKUPPLUNGEN

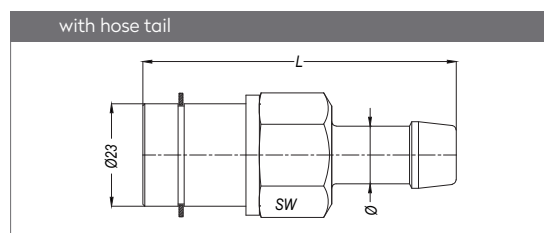

With Valve	Without Valve	SW	Ø	L
MM152.10 HGB 10	MM152.10 HGF 10	25	10	69.7
MM152.10 HGB 13	MM152.10 HGF 13	25	13	69.7

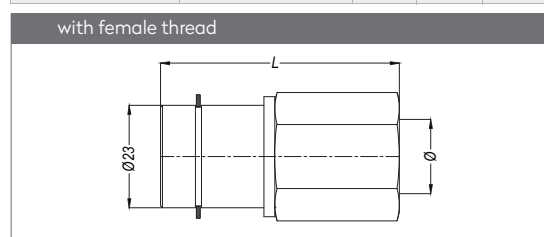

With Valve	Without Valve	SW	Ø	L
MM152.10 DGB 17	MM152.10 DGF 17	25	BSP 3/8"	53.7
MM152.10 NGB 17	MM152.10 NGF 17	25	NPT 3/8"	54.7

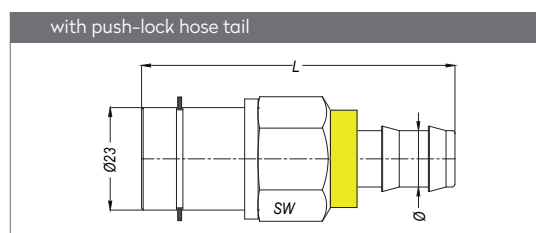

With Valve	Without Valve	SW	Ø	L
MM152.10 FGB 10	MM152.10 FGF 10	25	10	67.7
MM152.10 FGB 13	MM152.10 FGF 13	25	12.8	70

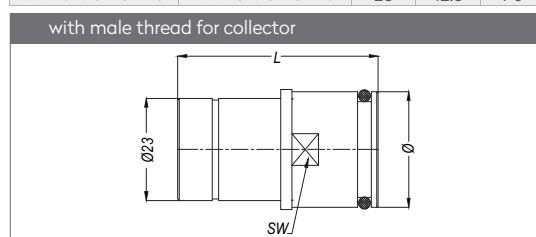

With Valve	Without Valve	SW	Ø	L
MM152.10 EGB 00	-	25	26	45.1

PLUGS STECKNIPPEL

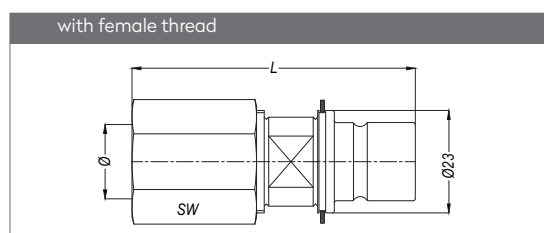

With Valve	Without Valve	SW	Ø	L
MK152.10 DUB 17	MK152.10 DUF 17	25	BSP 3/8"	63.7
MK152.10 NUB 17	MK152.10 NUF 17	25	NPT 3/8"	64.7

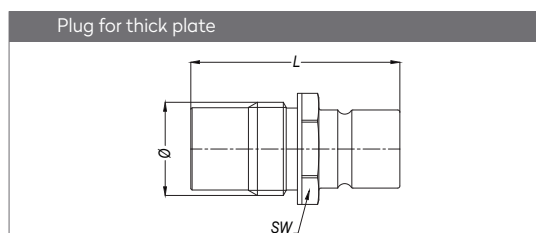

With Valve	Without Valve	SW	Ø	L
MK152.10 EUB 21	-	22	BSP 1/2"	47

ACCESSORIES ZUBEHÖR

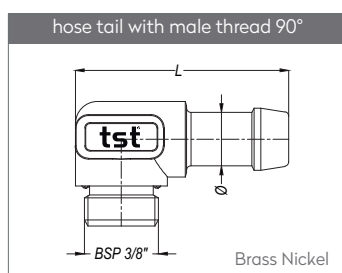

Part No.	Ø
109 EB 17.10	10
109 EB 17.13	13

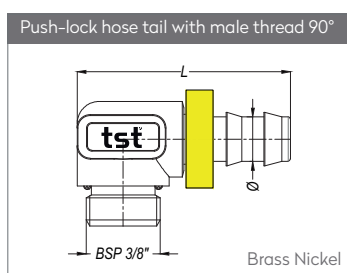

Part No.	Ø
109 EF 17.10	10
109 EF 17.13	13

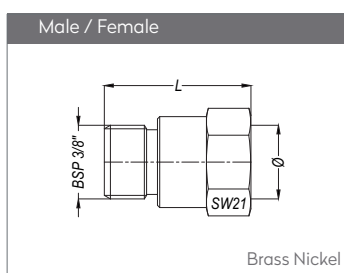

Part No.	Ø
109 EN 17	BSP 3/8"
109 NN 17	NPT 3/8"

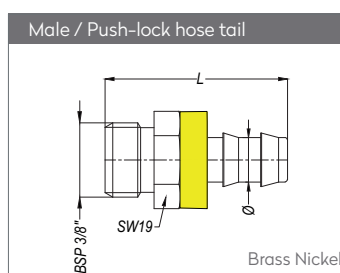

Part No.	Ø
EHF 17-10	10
EHF 17-13	13

Materials

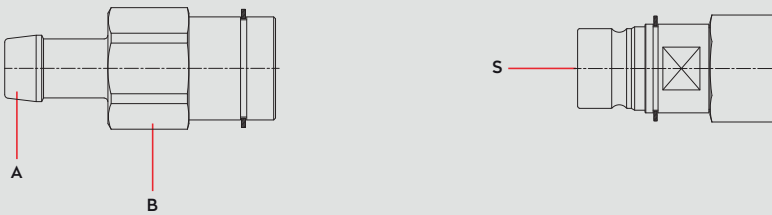

Material Code

A = Brass

B = Brass

S = AISI 303



0 - 16 bar



-26°C to + 200°C (FPM)

Shut Off Type



PLUG	COUPLING	OV 262 - 02150 OV 157 - 02600 OV 200 - 00900
	PLUG	OV 200 - 00900 OV 157 - 02100

FF

DN 12 mm

Multi Couplings Systems for quick changing of injection moulding and die cast equipments

Multikupplungensysteme für schnelles Wechseln und Verbinden der Kokillen und Spritzgußformen

Options

AISI303
Stainless Steel

Applications

- Temperature controlling

Compatible with

TST Design

MULTICOUPLINGS

MULTIKUPPLUNGEN

6 ↔ 6

SERIE 152.12M

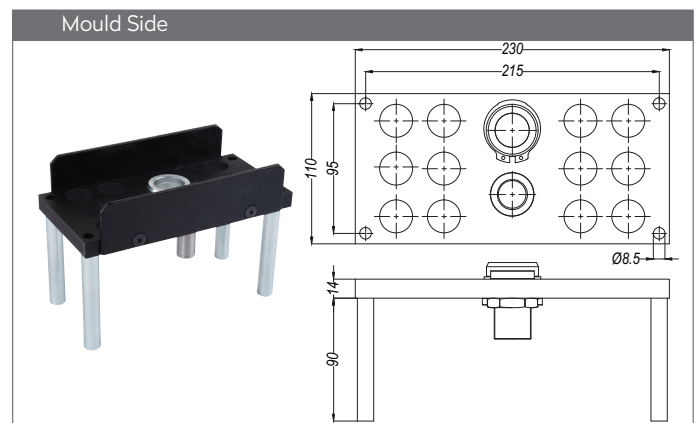
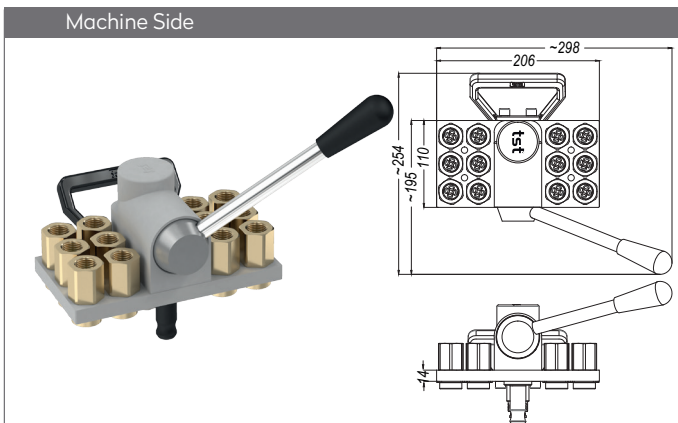

Part No.	Unit	Ø
MM152.12-12	-	without couplings
MM152.12-12 HGB 10	12	Hose tail 10 mm
MM152.12-12 HGB 13	12	Hose tail 13 mm
MM152.12-12 FGB 10	12	Push-Lock Hose tail 10 mm
MM152.12-12 FGB 13	12	Push-Lock Hose tail 13 mm
MM152.12-12 DGB 17	12	BSP female 3/8"
MM152.12-12 NGB 17	12	NPT female 3/8"

Part No.	Unit	Ø
MK152.12-12	-	without plugs
MK152.12-12 DUB 17	12	BSP female 3/8" with valve
MK152.12-12 NUB 17	12	NPT female 3/8" with valve
MK152.12-12 DU 17	12	BSP female 3/8" without valve
MK152.12-12 NU 17	12	NPT female 3/8" without valve

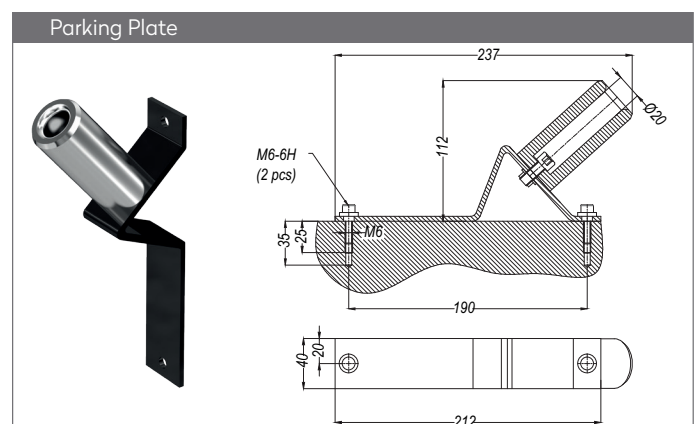
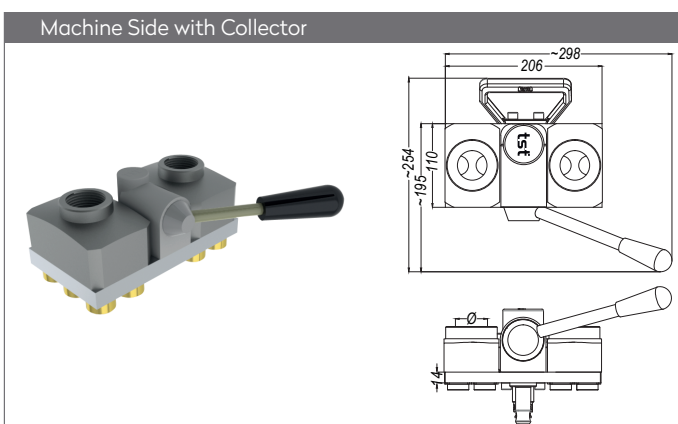

Part No.	Unit	Ø
MM152.12-12C	12	BSP female 1 1/4"
MM152.12-12CN	12	NPT female 1 1/4"

Part No.
MM108.06 P

MULTICOUPLINGS
MULTIKUPPLUNGEN

SERIE 152.12M

QUICK COUPLINGS SCHNELLKUPPLUNGEN

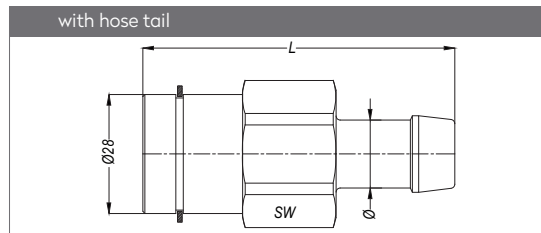

With Valve	Without Valve	SW	Ø	L
MM152.12 HGB 13	MM152.12 HGF 13	30	12.5	73.5
MM152.12 HGB 16	MM152.12 HGF 16	30	15.5	73.5

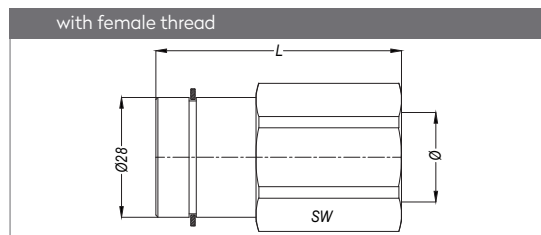

With Valve	Without Valve	SW	Ø	L
MM152.12 DGB 21	MM152.12 DGF 21	30	BSP 1/2"	57.5
MM152.12 NGB 21	MM152.12 NGF 21	30	NPT 1/2"	57.5

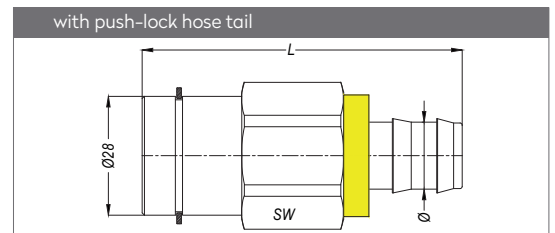

With Valve	Without Valve	SW	Ø	L
MM152.12 FGB 13	MM152.12 FGF 13	30	12.8	73.5
MM152.12 FGB 16	MM152.12 FGF 16	30	15.8	73.5

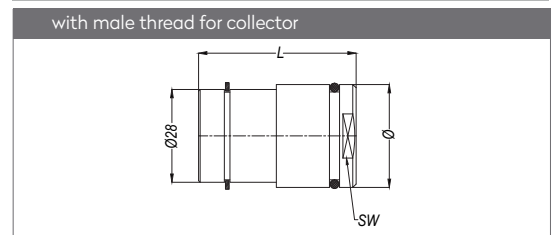

With Valve	Without Valve	SW	Ø	L
MM152.12 EGB 00	-	28	31	47.5

PLUGS STECKNIPPEL

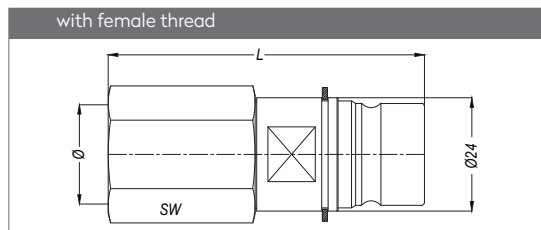

With Valve	Without Valve	SW	Ø	L
MK152.12 DUB 21	MK152.12 DUF 21	25	BSP 1/2"	66.7
MK152.12 NUB 21	MK152.12 NUF 21	25	NPT 1/2"	66.7

ACCESSORIES ZUBEHÖR

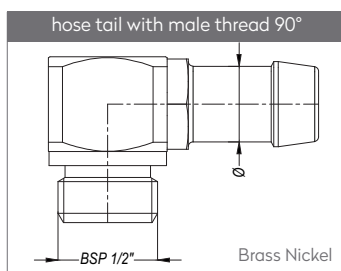

Part No.	Ø
112 EB 21.13	13
112 EB 21.16	16

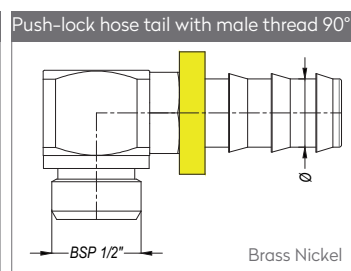

Part No.	Ø
112 EF 21.13	12.8
112 EF 21.16	16

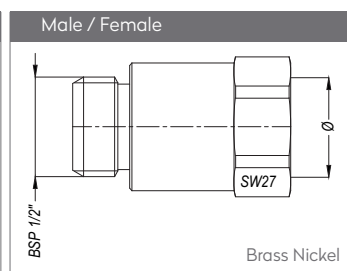

Part No.	Ø
112 EN 21	BSP 1/2"
112 NN 21	NPT 1/2"

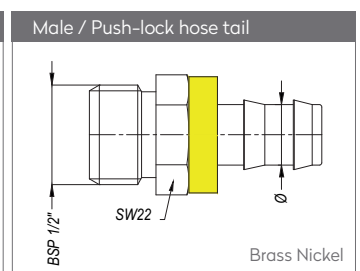

Part No.	Ø
EHF 21-13	13
EHF 21-16	16

DN9

MULTICOUPLINGS
MULTIKUPPLUNGEN

SERIE 155.09M

Materials

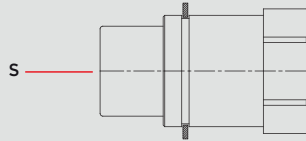
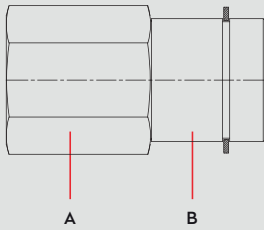

Material Code

A = Brass

B = Brass

S = AISI 303



0 - 16 bar



-26°C to + 200°C (FPM)

Shut Off
Type

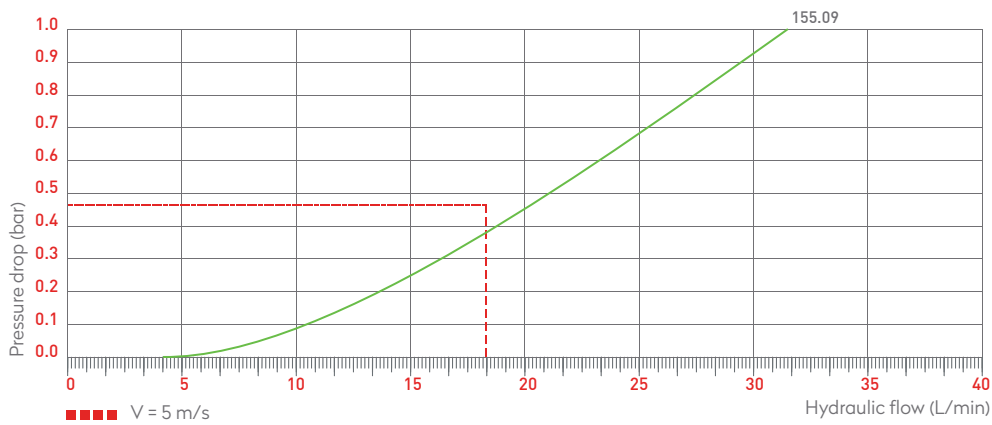

Options

HT

COLOURED
PLATE

EPDM



COUPLING

OV 157 - 02100
OV 157 - 00700
OV 200 - 01700

PLUG

OV 157 - 00600

Applications

- Temperature controlling

DN

9 mm

Compatible with

10 ↔ 10

SERIE 155.09M

Multi Couplings Systems for quick changing of injection moulding and die cast equipments

Multikupplungensysteme für schnelles Wechseln und Verbinden der Kokillen und Spritzgußformen

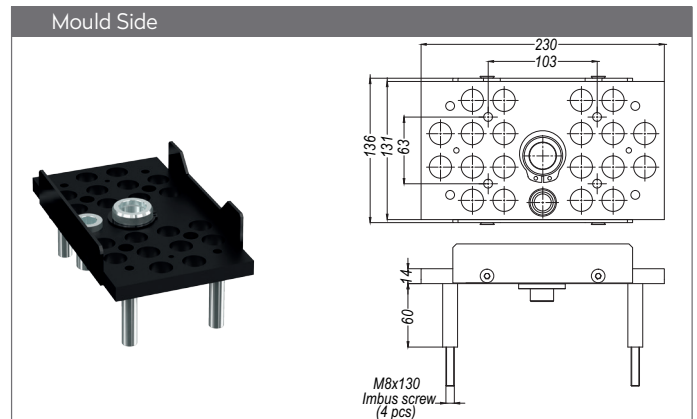
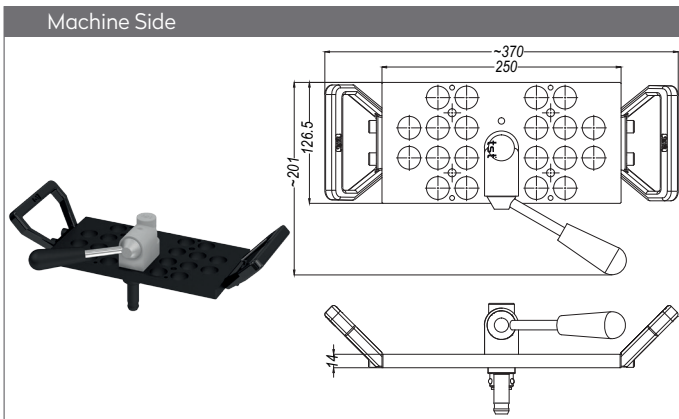

Part No.	Unit	Ø
MM155.09-20-SP01	-	without couplings
MM155.09-20 HGB 10-SP01	20	Hose tail 10 mm
MM155.09-20 HGB 13-SP01	20	Hose tail 13 mm
MM155.09-20 FGB 10-SP01	20	Push-Lock Hose tail 10 mm
MM155.09-20 FGB 13-SP01	20	Push-Lock Hose tail 13 mm
MM155.09-20 DGB 17-SP01	20	BSP female 3/8"
MM155.09-20 NGB 17-SP01	20	NPT female 3/8"

Part No.	Unit	Ø
MK155.09-20-SP01	-	without plugs
MK155.09-20 DUB 17-SP01	20	BSP female 3/8" with valve
MK155.09-20 NUB 17-SP01	20	NPT female 3/8" with valve
MK155.09-20 DU 17-SP01	20	BSP female 3/8" without valve
MK155.09-20 NU 17-SP01	20	NPT female 3/8" without valve

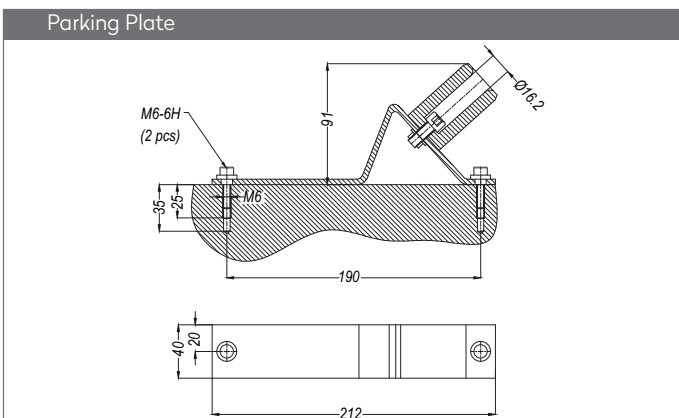

Part No.
MM155.09-12P

MULTICOUPLINGS

MULTIKUPPLUNGEN

6 ↔ 6

SERIE 155.09M

Multi Couplings Systems for quick changing of injection moulding and die cast equipments

Multikupplungensysteme für schnelles Wechseln und Verbinden der Kokillen und Spritzgußformen

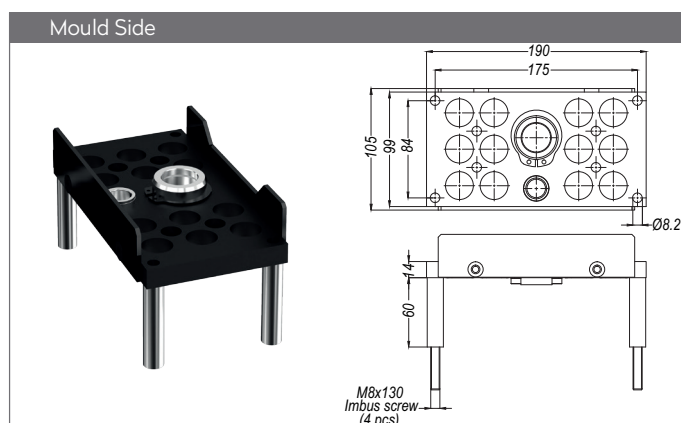
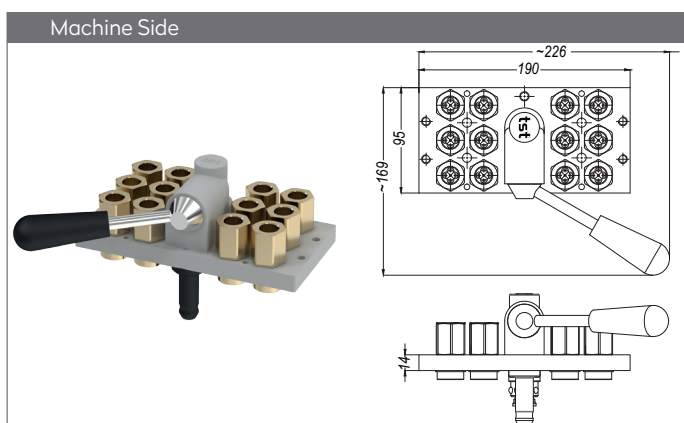

Part No.	Unit	Ø
MM155.09-12-SP01	-	without couplings
MM155.09-12 HGB 10-SP01	12	Hose tail 10 mm
MM155.09-12 HGB 13-SP01	12	Hose tail 13 mm
MM155.09-12 FGB 10-SP01	12	Push-Lock Hose tail 10 mm
MM155.09-12 FGB 13-SP01	12	Push-Lock Hose tail 13 mm
MM155.09-12 DGB 17-SP01	12	BSP female 3/8"
MM155.09-12 NGB 17-SP01	12	NPT female 3/8"

Part No.	Unit	Ø
MK155.09-12-SP01	-	without plugs
MK155.09-12 DUB 17-SP01	12	BSP female 3/8" with valve
MK155.09-12 NUB 17-SP01	12	NPT female 3/8" with valve
MK155.09-12 DU 17-SP01	12	BSP female 3/8" without valve
MK155.09-12 NU 17-SP01	12	NPT female 3/8" without valve

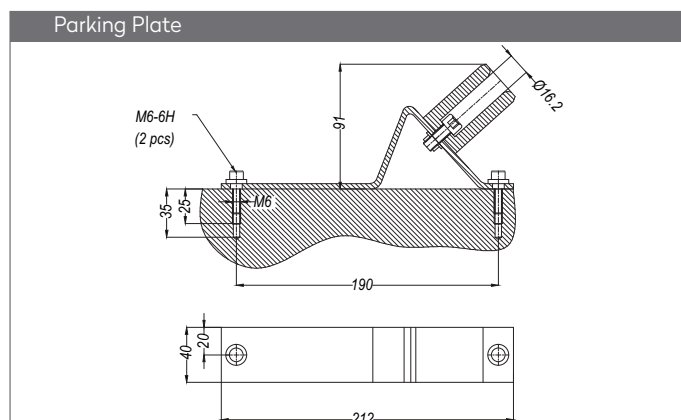
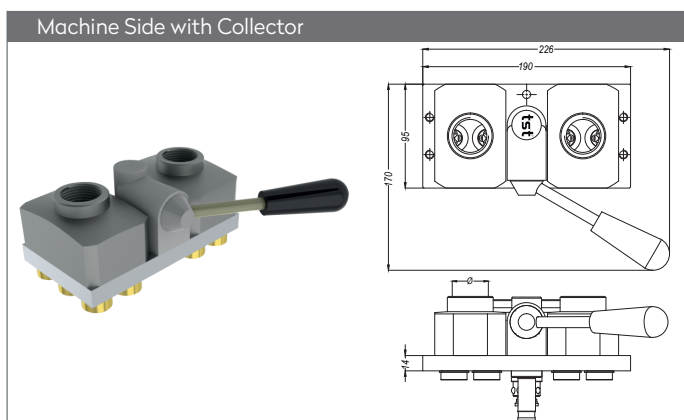

Part No.	Unit	Ø
MM155.09-12C-SP01	12	BSP female 1"
MM155.09-12CN-SP01	12	NPT female 1"

Part No.
MM155.09-12P

SERIE 155.09M

Multi Couplings Systems for quick changing of injection moulding and die cast equipments

Multikupplungensysteme für schnelles Wechseln und Verbinden der Kokillen und Spritzgußformen

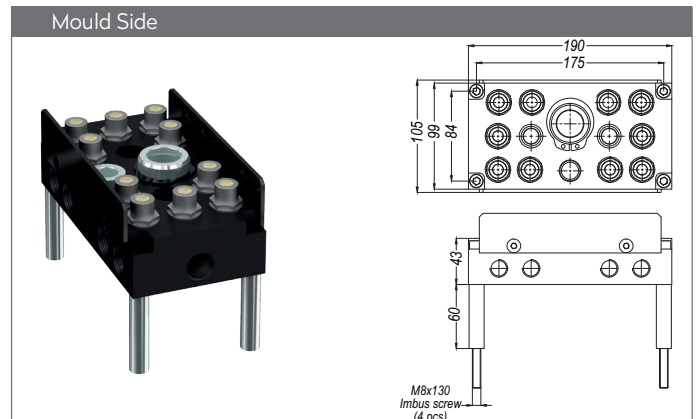
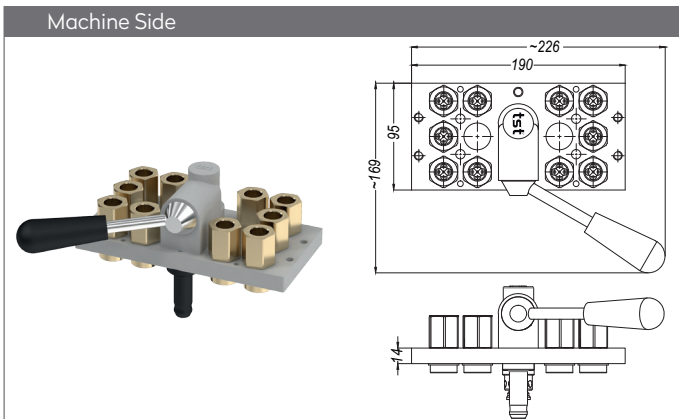

Part No.	Unit	Ø
MM155.09-12-SP01	-	without couplings
MM155.09-10 HGB 10-SP01	10	Hose tail 9 mm
MM155.09-10 HGB 12-SP01	10	Hose tail 12 mm
MM155.09-10 FGB 10-SP01	10	Push-Lock Hose tail 10 mm
MM155.09-10 FGB 13-SP01	10	Push-Lock Hose tail 13 mm
MM155.09-10 DGB 17-SP01	10	BSP female 3/8"
MM155.09-10 NGB 17-SP01	10	NPT female 3/8"

Part No.	Unit	Ø
MK155.09-10	10	BSP male 1/2" without valve
MK155.09-10 V	10	BSP male 1/2" with valve

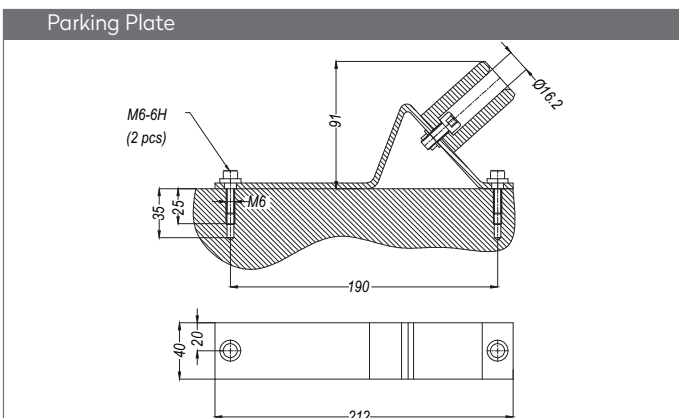

Part No.
MM155.09-12P

4 ↔ 4

SERIE 155.09M

Multi Couplings Systems for quick changing of injection moulding and die cast equipments

Multikupplungensysteme für schnelles Wechseln und Verbinden der Kokillen und Spritzgußformen

Machine Side

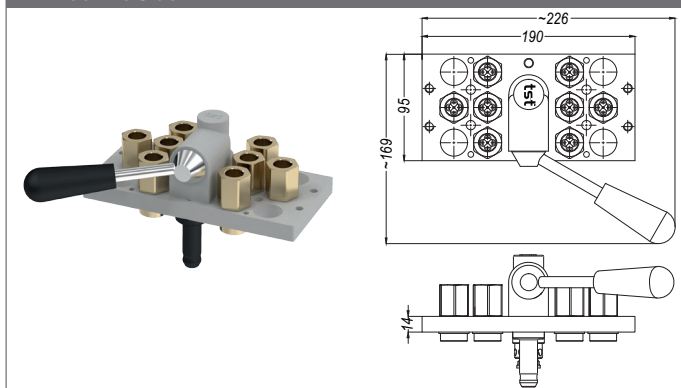

Mould Side

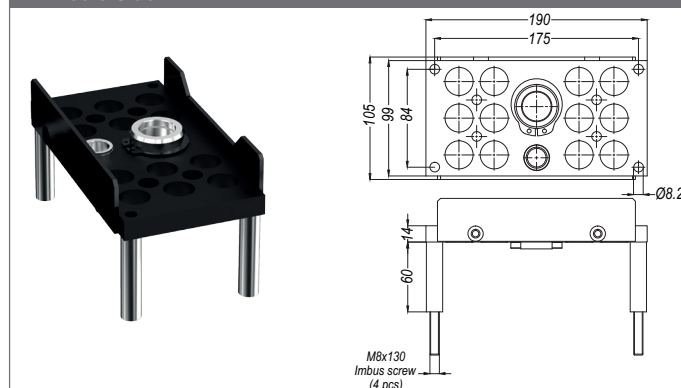

Part No.	Unit	Ø
MM155.09-08-SP01	-	without couplings
MM155.09-08 HGB 10-SP01	8	Hose tail 10 mm
MM155.09-08 HGB 12-SP01	8	Hose tail 12 mm
MM155.09-08 FGB 10-SP01	8	Push-Lock Hose tail 10 mm
MM155.09-08 FGB 13-SP01	8	Push-Lock Hose tail 13 mm
MM155.09-08 DGB 17-SP01	8	BSP female 3/8"
MM155.09-08 NGB 17-SP01	8	NPT female 3/8"

Part No.	Unit	Ø
MK155.09-08-SP01	-	without plugs
MK155.09-08 DUB 17-SP01	8	BSP female 3/8" with valve
MK155.09-08 NUB 17-SP01	8	NPT female 3/8" with valve
MK155.09-08 DU 17-SP01	8	BSP female 3/8" without valve
MK155.09-08 NU 17-SP01	8	NPT female 3/8" without valve

Parking Plate

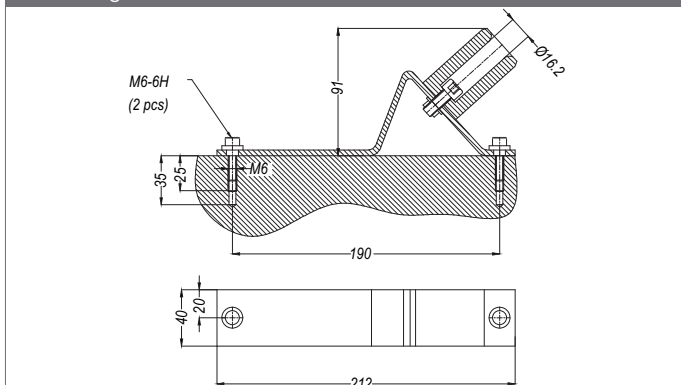

Part No.

MM155.09-12P

SERIE 155.09M

Multi Couplings Systems for quick changing of injection moulding and die cast equipments

Multikupplungensysteme für schnelles Wechseln und Verbinden der Kokillen und Spritzgußformen

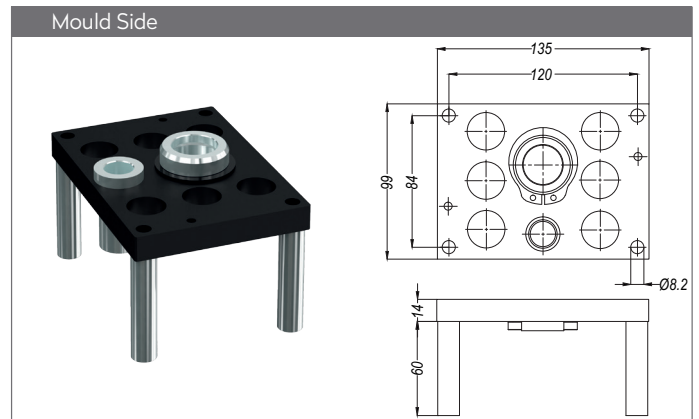
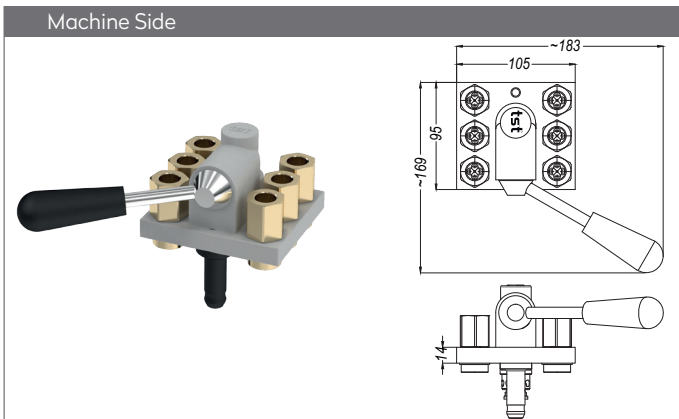

Part No.	Unit	Ø
MM155.09-06-SP01	-	without couplings
MM155.09-06 HGB 10-SP01	6	Hose tail 10 mm
MM155.09-06 HGB 12-SP01	6	Hose tail 12 mm
MM155.09-06 FGB 10-SP01	6	Push-Lock Hose tail 10 mm
MM155.09-06 FGB 13-SP01	6	Push-Lock Hose tail 13 mm
MM155.09-06 DGB 17-SP01	6	BSP female 3/8"
MM155.09-06 NGB 17-SP01	6	NPT female 3/8"

Part No.	Unit	Ø
MK155.09-06-SP01	-	without plugs
MK155.09-06 DUB 17-SP01	6	BSP female 3/8" with valve
MK155.09-06 NUB 17-SP01	6	NPT female 3/8" with valve
MK155.09-06 DU 17-SP01	6	BSP female 3/8" without valve
MK155.09-06 NU 17-SP01	6	NPT female 3/8" without valve

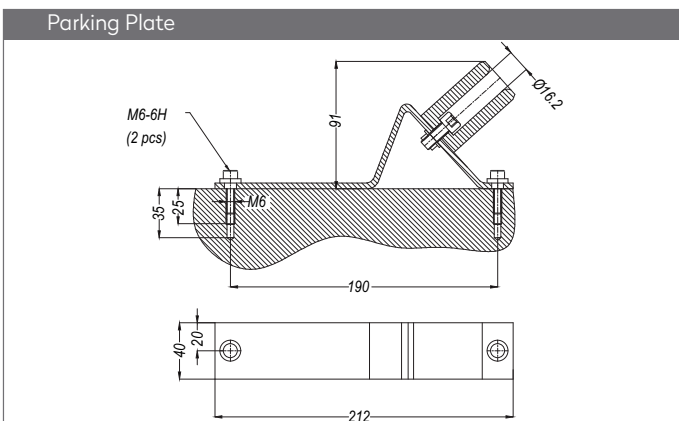

Part No.
MM155.09-12P

MULTICOUPLINGS
 MULTIKUPPLUNGEN

SERIE 155.09M

QUICK COUPLINGS SCHNELLKUPPLUNGEN

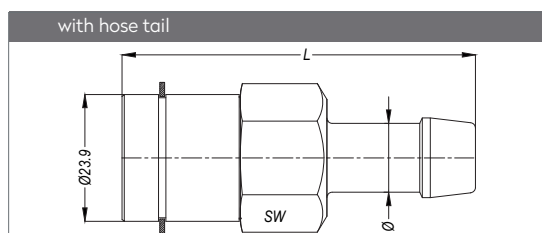

With Valve	Without Valve	SW	Ø	L
MM155.09 HGB 10	MM155.09 HGF 10	25	10	66.3
MM155.09 HGB 13	MM155.09 HGF 13	25	13	66.3

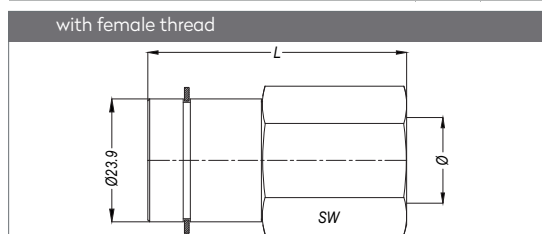

With Valve	Without Valve	SW	Ø	L
MM155.09 DGB 17	MM155.09 DGF 17	25	BSP 3/8"	50.3
MM155.09 NGB 17	MM155.09 NGF 17	25	NPT 3/8"	51.3

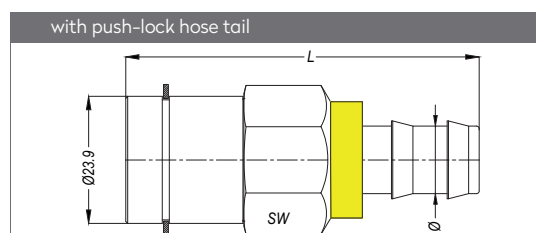

With Valve	Without Valve	SW	Ø	L
MM155.09 FGB 10	MM155.09 FGF 10	25	10	64.3
MM155.09 FGB 13	MM155.09 FGF 13	25	13	66.6

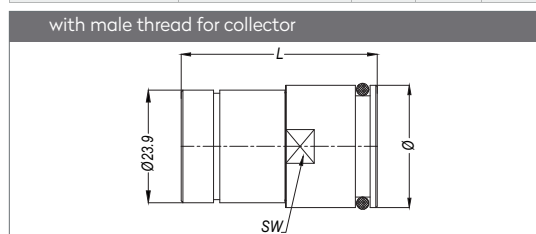

With Valve	Without Valve	SW	Ø	L
MM155.09 EGB 00	-	25	26	41.7

PLUGS STECKNIPPEL

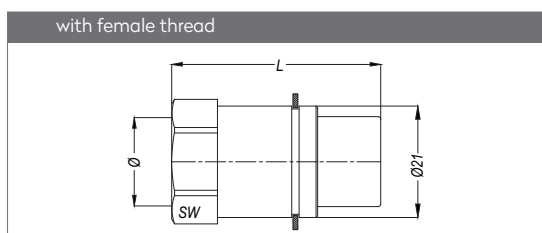

With Valve	Without Valve	SW	Ø	L
MK155.09 DUB 17	MK155.09 DUF 17	21	BSP 3/8"	39.4
MK155.09 NUB 17	MK155.09 NUF 17	21	NPT 3/8"	40.4

ACCESSORIES ZUBEHÖR

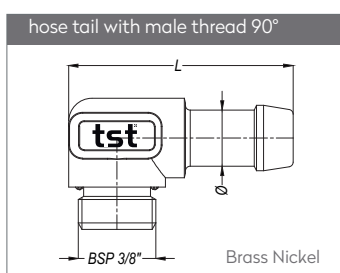

Part No.	Ø
109 EB 17.10	10
109 EB 17.13	13

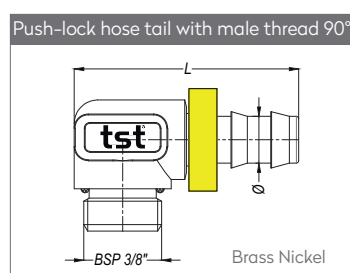

Part No.	Ø
109 EF 17.10	10
109 EF 17.13	13

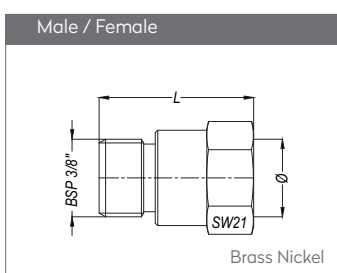

Part No.	Ø
109 EN 17	BSP 3/8"
109 NN 17	NPT 3/8"

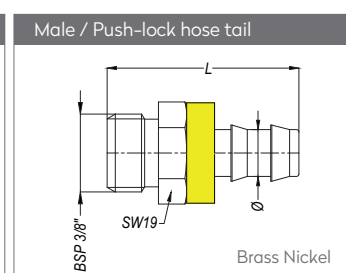

Part No.	Ø
EHF 17-10	10
EHF 17-13	13

Materials

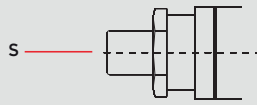
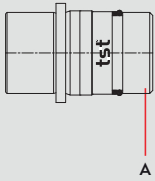

SCREW LOCKING

Material Code

A = AISI 303

S = AISI 420



0 - 180 bar



-26°C to + 200°C (FPM)

Shut Off Type

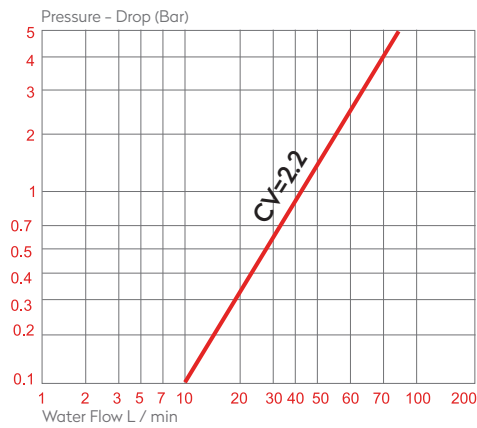

QUICK COUPLINGS SCHNELLKUPPLUNGEN

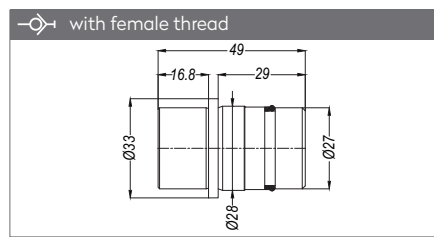

Part no.
MK104.08 DGB 00

PLUGS STECKNIPPEL

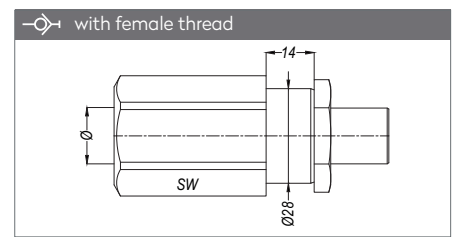

Part no.	Ø	SW
104.08 DUB 17 MP	BSP 3/8"	32
104.08 DUB 21 MP	BSP 1/2"	32
104.08 NUB 17 MP	NPT 3/8"	32
104.08 NUB 21 MP	NPT 1/2"	32

Options



	MK COUPLING	OV 178 - 02195 - 88
		OV 200 - 00550 - 88
		OV 262 - 01715 - 88
	MM PLUG	OV 262 - 01715 - 88
		OV 178 - 02195 - 88
		OV 200 - 00550 - 88

Applications

- Hydraulic Circuits



Compatible with

MULTICOUPLINGS
 MULTIKUPPLUNGEN

3 ↔ 3

SERIE 208M

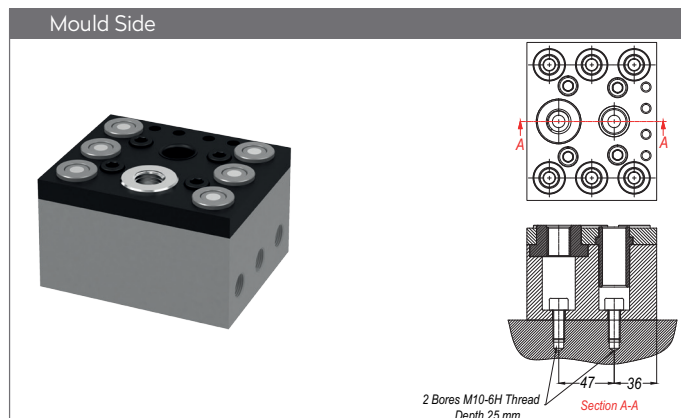
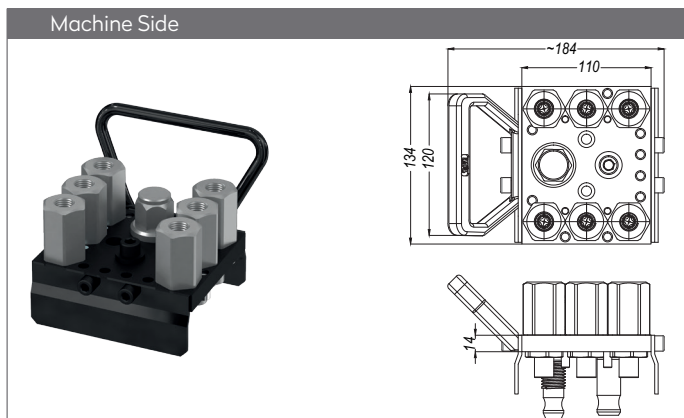

Part No.	Unit	Ø
MM208.06	-	without plugs
MM208.06 G17	6	104.08 DUB 17MP (3/8" BSP)
MM208.06 G21	6	104.08 DUB 21MP (1/2" BSP)
MM208.06 N17	6	104.08 NUB 17MP (3/8" NPT)
MM208.06 N21	6	104.08 NUB 21MP (1/2" NPT)
MM208.06 U14	6	104.08 UUB 14MP (9/16" UNF)
MM208.06 U19	6	104.08 UUB 19MP (3/4" UNF)

Part No.	Unit	Ø
	-	without couplings
MK208.06 G17	6	MK104.08 DGB 00
	6	3/8" BSP female thread holes on sides
MK208.06 G21	6	MK104.08 DGB 00
	6	1/2" BSP female thread holes on sides
MK208.06 N17	6	MK104.08 DGB 00
	6	3/8" NPT female thread holes on sides
MK208.06 N21	6	MK104.08 DGB 00
	6	1/2" NPT female thread holes on sides
MK208.06 U14	6	MK104.08 DGB 00
	6	9/16" UNF female thread holes on sides
MK208.06 U19	6	MK104.08 DGB 00
	6	3/4" UNF female thread holes on sides

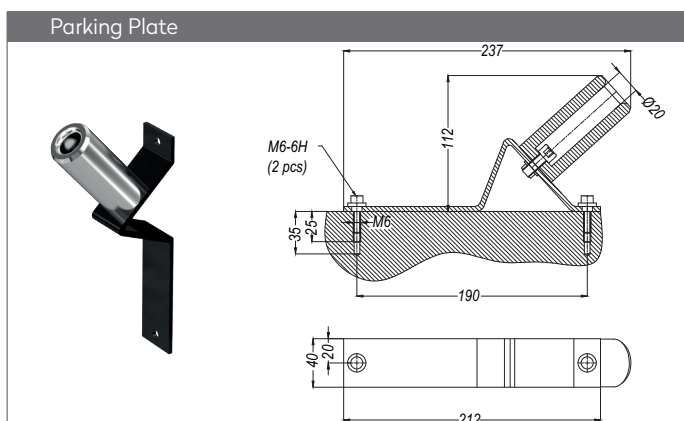

Part No.
MM108.06 P

SERIE 208M

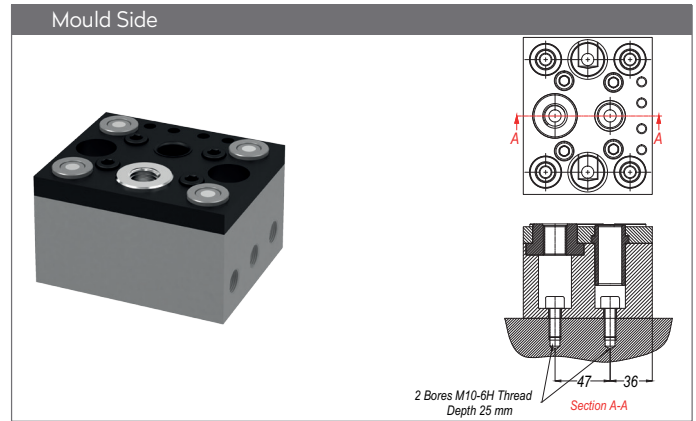
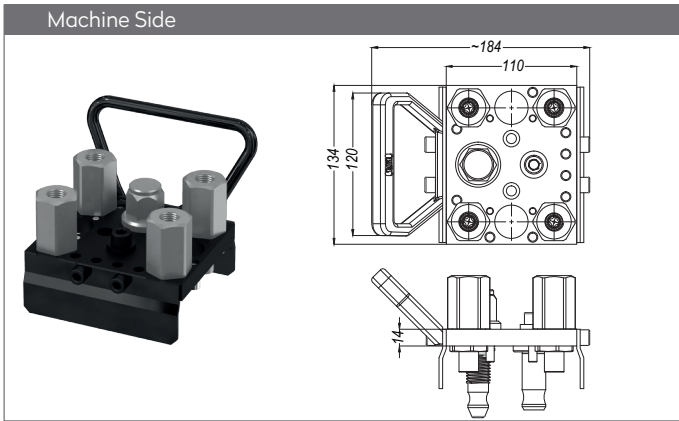

Part No.	Unit	Ø
	-	without plugs
MM208.04 G17	4	104.08 DUB 17MP (3/8" BSP)
MM208.04 G21	4	104.08 DUB 21MP (1/2" BSP)
MM208.04 N17	4	104.08 NUB 17MP (3/8" NPT)
MM208.04 N21	4	104.08 NUB 21MP (1/2" NPT)
MM208.04 U14	4	104.08 UUB 14MP (9/16" UNF)
MM208.04 U19	4	104.08 UUB 19MP (3/4" UNF)

Part No.	Unit	Ø
	-	without couplings
MK208.04 G17	4	MK104.08 DGB 00
	6	3/8" BSP female thread holes on sides
MK208.04 G21	4	MK104.08 DGB 00
	6	1/2" BSP female thread holes on sides
MK208.04 N17	4	MK104.08 DGB 00
	6	3/8" NPT female thread holes on sides
MK208.04 N21	4	MK104.08 DGB 00
	6	1/2" NPT female thread holes on sides
MK208.04 U14	4	MK104.08 DGB 00
	6	9/16" UNF female thread holes on sides
MK208.04 U19	4	MK104.08 DGB 00
	6	3/4" UNF female thread holes on sides

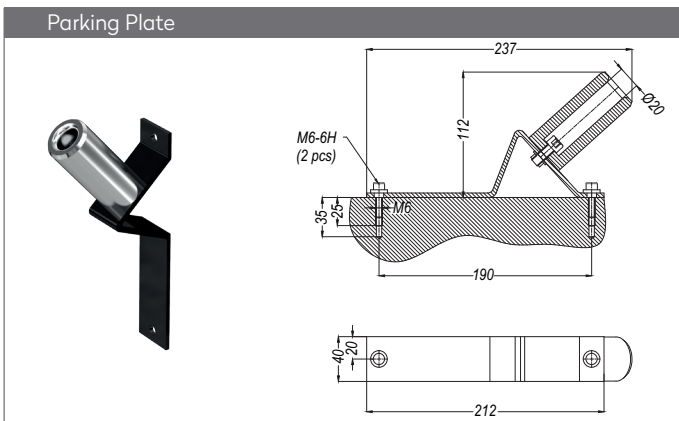

Part No.
MM108.06 P

MULTICOUPLINGS
 MULTIKUPPLUNGEN

1 ↔ 1

SERIE 208M

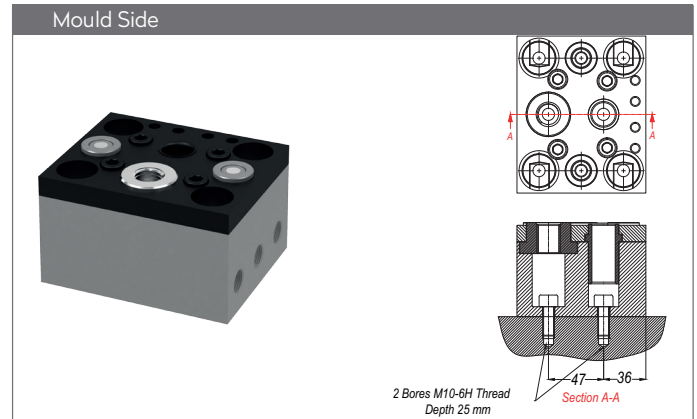
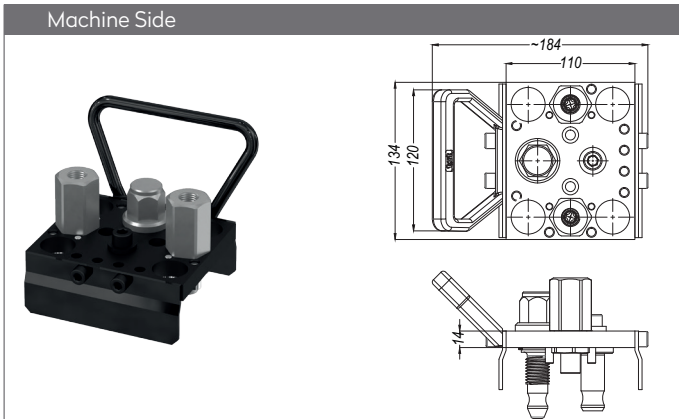

Part No.	Unit	Ø
	-	without plugs
MM208.02 G17	2	104.08 DUB 17MP (3/8" BSP)
MM208.02 G21	2	104.08 DUB 21MP (1/2" BSP)
MM208.02 N17	2	104.08 NUB 17MP (3/8" NPT)
MM208.02 N21	2	104.08 NUB 21MP (1/2" NPT)
MM208.02 U14	2	104.08 UUB 14MP (9/16" UNF)
MM208.02 U19	2	104.08 UUB 19MP (3/4" UNF)

Part No.	Unit	Ø
	-	without couplings
MK208.02 G17	2	MK104.08 DGB 00
	6	3/8" BSP female thread holes on sides
MK208.02 G21	2	MK104.08 DGB 00
	6	1/2" BSP female thread holes on sides
MK208.02 N17	2	MK104.08 DGB 00
	6	3/8" NPT female thread holes on sides
MK208.02 N21	2	MK104.08 DGB 00
	6	1/2" NPT female thread holes on sides
MK208.02 U14	2	MK104.08 DGB 00
	6	9/16" UNF female thread holes on sides
MK208.02 U19	2	MK104.08 DGB 00
	6	3/4" UNF female thread holes on sides

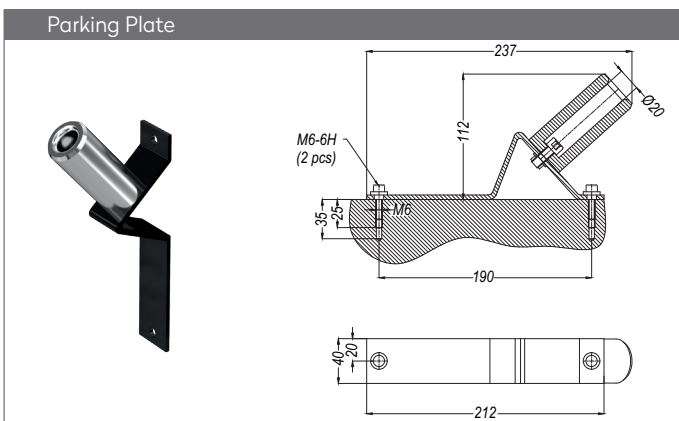

Part No.
MM108.06 P

Materials

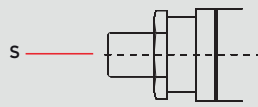
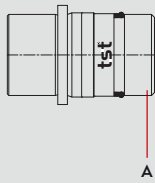

SCREW LOCKING

Material Code

A = AISI 303

S = AISI 420



0 - 180 bar



-26°C to + 200°C (FPM)

Shut Off Type



FF

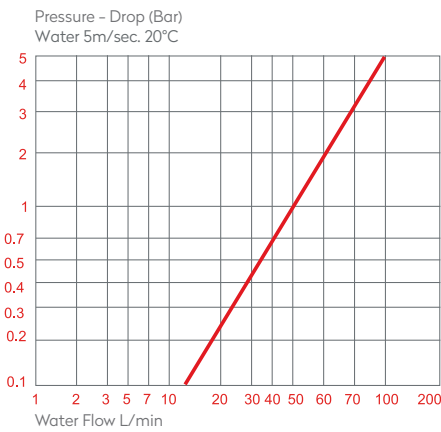

QUICK COUPLINGS SCHNELLKUPPLUNGEN

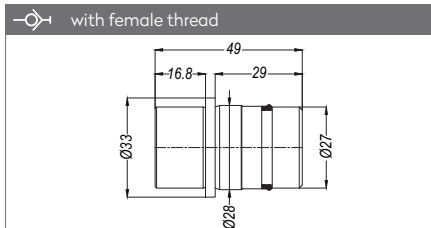

Part no.
MK104.10 DGB 00

PLUGS STECKNIPPEL

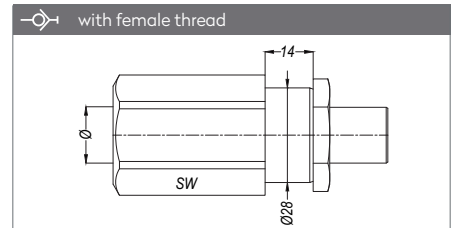

Part no.	Ø	SW
104.08 DUB 17 MP	BSP 3/8"	32
104.08 DUB 21 MP	BSP 1/2"	32
104.08 NUB 17 MP	NPT 3/8"	32
104.08 NUB 21 MP	NPT 1/2"	32

Options



MMK COUPLING	OV 262 - 01905 - 88
	OV 178 - 01280 - 88
	OV 178 - 02195 - 88
MM PLUG	OV 190 - 00930 - 88
	OV 178 - 02195 - 88
	OV 262 - 01715 - 88

Applications

- Hydraulic Circuits

DN

10 mm

Compatible with

3 ↔ 3

SERIE 208M-HF

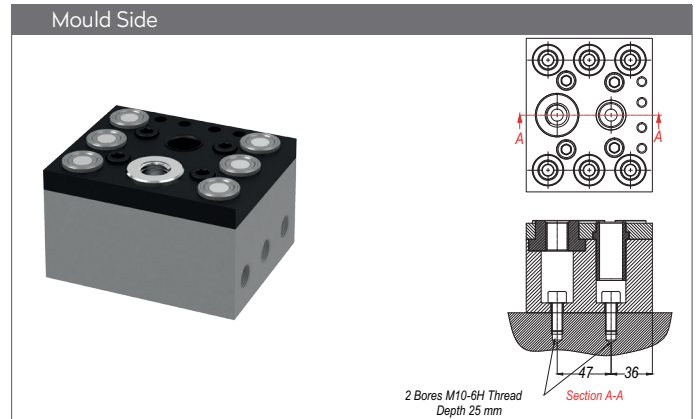
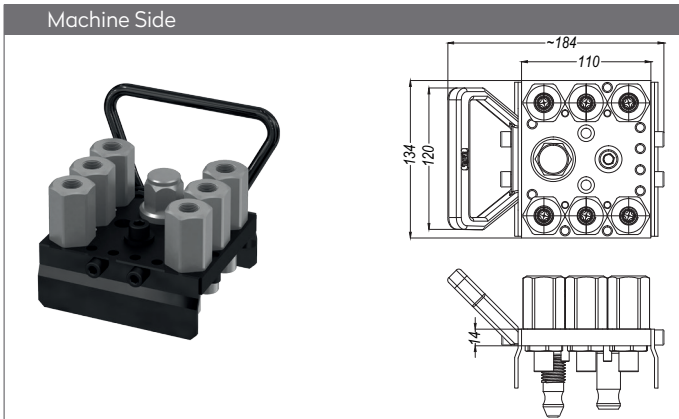

Part No.	Unit	Ø
	-	without plugs
MM208.06 G17-HF	6	104.10 DUB 17MP (3/8" BSP)
MM208.06 G21-HF	6	104.10 DUB 21MP (1/2" BSP)
MM208.06 N17-HF	6	104.10 NUB 17MP (3/8" NPT)
MM208.06 N21-HF	6	104.10 NUB 21MP (1/2" NPT)
MM208.06 U14-HF	6	104.10 UUB 14MP (9/16" UNF)
MM208.06 U19-HF	6	104.10 UUB 19MP (3/4" UNF)

Part No.	Unit	Ø
	-	without couplings
MK208.06 G17-HF	6	MK104.10 DGB 00
	6	3/8" BSP female thread holes on sides
MK208.06 G21-HF	6	MK104.10 DGB 00
	6	1/2" BSP female thread holes on sides
MK208.06 N17-HF	6	MK104.10 DGB 00
	6	3/8" NPT female thread holes on sides
MK208.06 N21-HF	6	MK104.10 DGB 00
	6	1/2" NPT female thread holes on sides
MK208.06 U14-HF	6	MK104.10 DGB 00
	6	9/16" UNF female thread holes on sides
MK208.06 U19-HF	6	MK104.10 DGB 00
	6	3/4" UNF female thread holes on sides

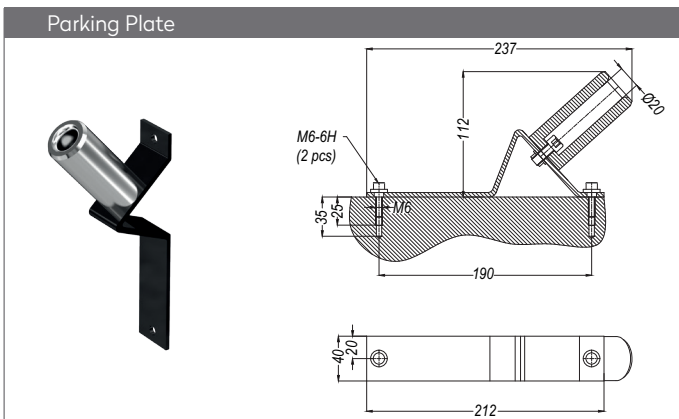

Part No.
MM108.06 P

SERIE 208M-HF

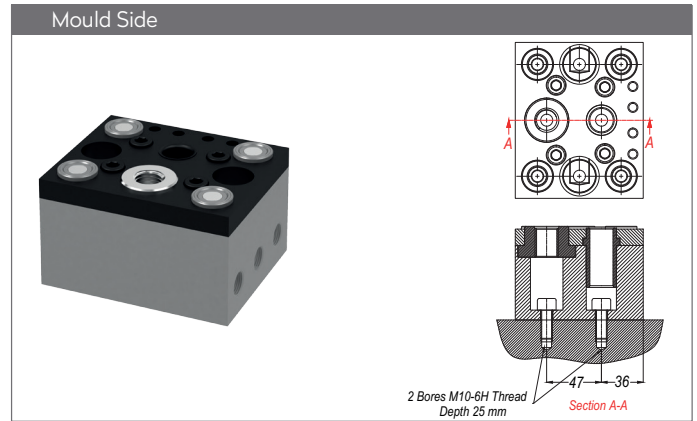
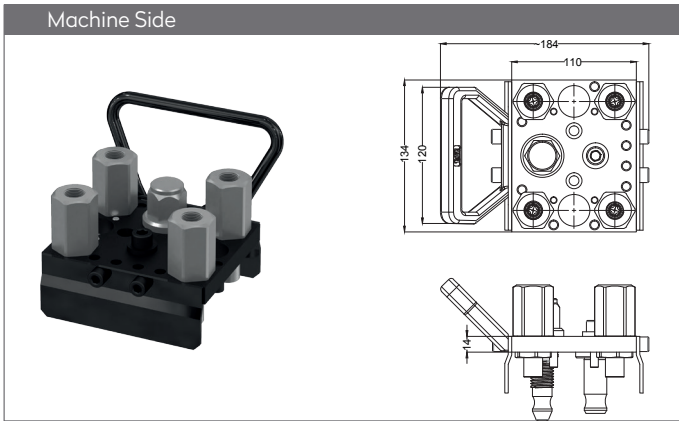

Part No.	Unit	Ø
	-	without plugs
MM208.04 G17-HF	4	104.10 DUB 17MP (3/8" BSP)
MM208.04 G21-HF	4	104.10 DUB 21MP (1/2" BSP)
MM208.04 N17-HF	4	104.10 NUB 17MP (3/8" NPT)
MM208.04 N21-HF	4	104.10 NUB 21MP (1/2" NPT)
MM208.04 U14-HF	4	104.10 UUB 14MP (9/16" UNF)
MM208.04 U19-HF	4	104.10 UUB 19MP (3/4" UNF)

Part No.	Unit	Ø
	-	without couplings
MK208.04 G17-HF	4	MK104.10 DGB 00
	6	3/8" BSP female thread holes on sides
MK208.04 G21-HF	4	MK104.10 DGB 00
	6	1/2" BSP female thread holes on sides
MK208.04 N17-HF	4	MK104.10 DGB 00
	6	3/8" NPT female thread holes on sides
MK208.04 N21-HF	4	MK104.10 DGB 00
	6	1/2" NPT female thread holes on sides
MK208.04 U14-HF	4	MK104.10 DGB 00
	6	9/16" UNF female thread holes on sides
MK208.04 U19-HF	4	MK104.10 DGB 00
	6	3/4" UNF female thread holes on sides

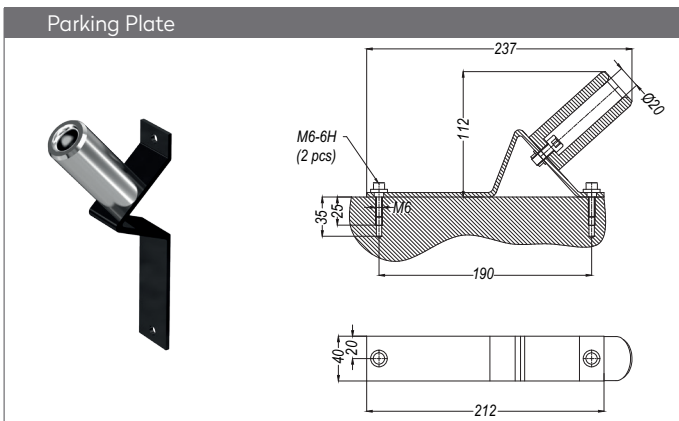

Part No.
MM108.06 P

1 ⇌ 1

SERIE 208M-HF

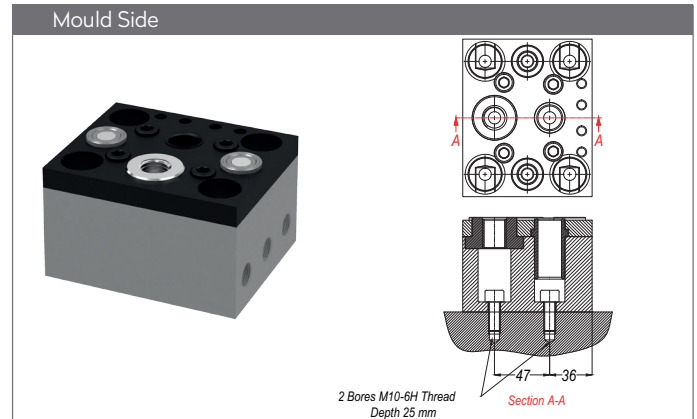
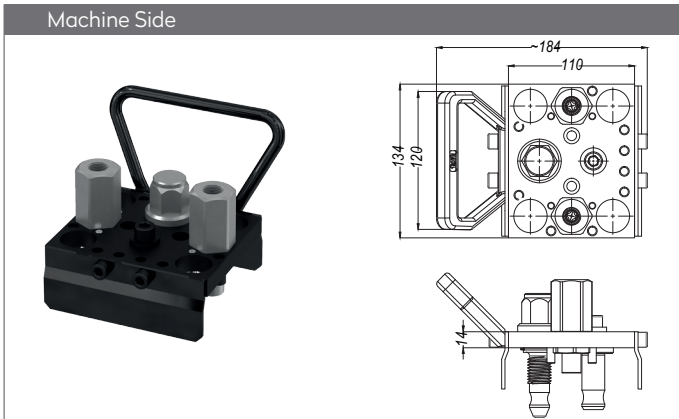

Part No.	Unit	Ø
	-	without plugs
MM208.02 G17-HF	2	104.10 DUB 17MP (3/8" BSP)
MM208.02 G21-HF	2	104.10 DUB 21MP (1/2" BSP)
MM208.02 N17-HF	2	104.10 NUB 17MP (3/8" NPT)
MM208.02 N21-HF	2	104.10 NUB 21MP (1/2" NPT)
MM208.02 U14-HF	2	104.10 UUB 14MP (9/16" UNF)
MM208.02 U19-HF	2	104.10 UUB 19MP (3/4" UNF)

Part No.	Unit	Ø
	-	without couplings
MK208.02 G17-HF	2	MK104.10 DGB 00
	6	3/8" BSP female thread holes on sides
MK208.02 G21-HF	2	MK104.10 DGB 00
	6	1/2" BSP female thread holes on sides
MK208.02 N17-HF	2	MK104.10 DGB 00
	6	3/8" NPT female thread holes on sides
MK208.02 N21-HF	2	MK104.10 DGB 00
	6	1/2" NPT female thread holes on sides
MK208.02 U14-HF	2	MK104.10 DGB 00
	6	9/16" UNF female thread holes on sides
MK208.02 U19-HF	2	MK104.10 DGB 00
	6	3/4" UNF female thread holes on sides

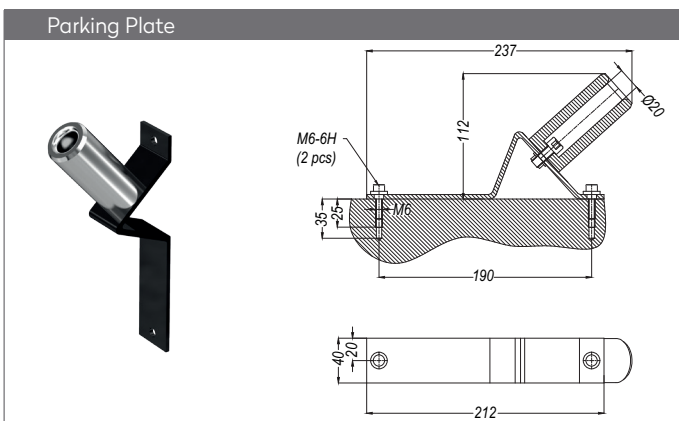

Part No.
MM108.06 P

SERIE 208M-HF

Screw Locking Model Manifold
Schraubverriegelung Multikupplung

If you want to change lever locking mechanism to screw type.
Please order MM 208 KS 00 for mobile side and MK 208 SM 00 for tool side.

Zum Umbau auf Spindelverriegelung bestellen Sie MM 208 KS 00, für die mobile Seite und MK 208 SM 00 für die Werkzeugseite.

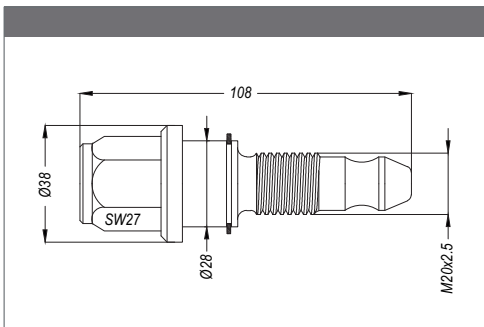
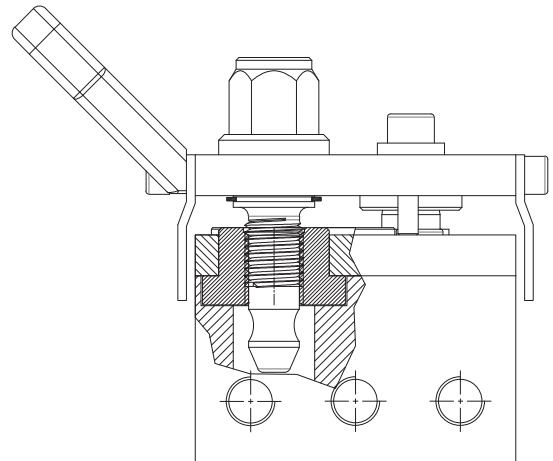
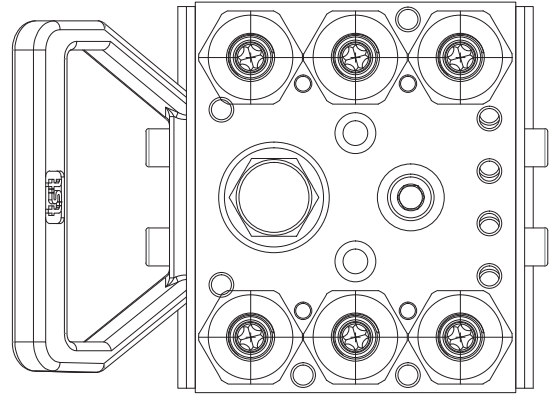

Part No.

MM 208 KS 00

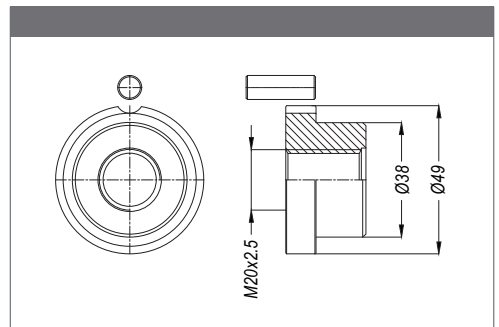

Part No.

MK 208 SM 00

WATER FLOW INDICATOR
 DURCHFLUSSINDIKATOR

SERIE SAGK

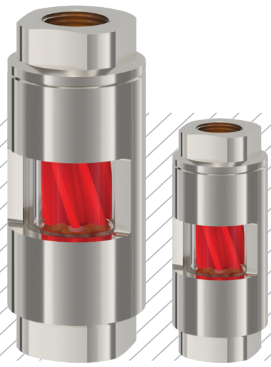

Materials

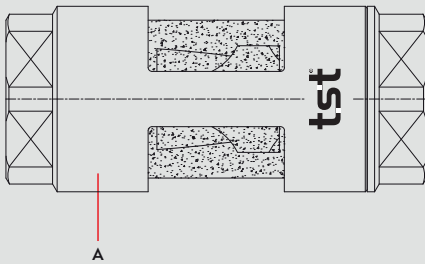

Material Code

A = Brass Nickel Plated



0 - 20 bar



-20°C to + 100°C

QUICK COUPLINGS SCHNELLKUPPLUNGEN

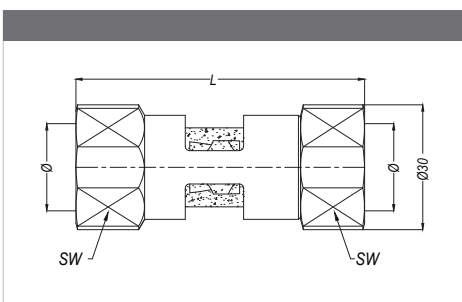

Part No.	Ø	DN	SW	L	Ød
SAGK 21-DN14	BSP 1/2"	14	27	69.4	30

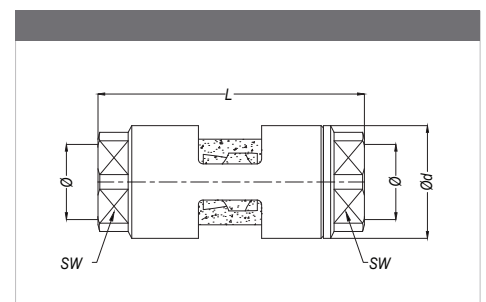

Part No.	Ø	DN	SW	L	Ød
SAGK 13	BSP 1/4"	14	19	59.1	25
SAGK 17	BSP 3/8"	14	19	59.1	25
SAGK 21	BSP 1/2"	30	40	106.5	47
SAGK 26	BSP 3/4"	30	40	106.5	47
SAGK 33	BSP 1"	30	40	106.5	47

MOULD ACCESSORIES

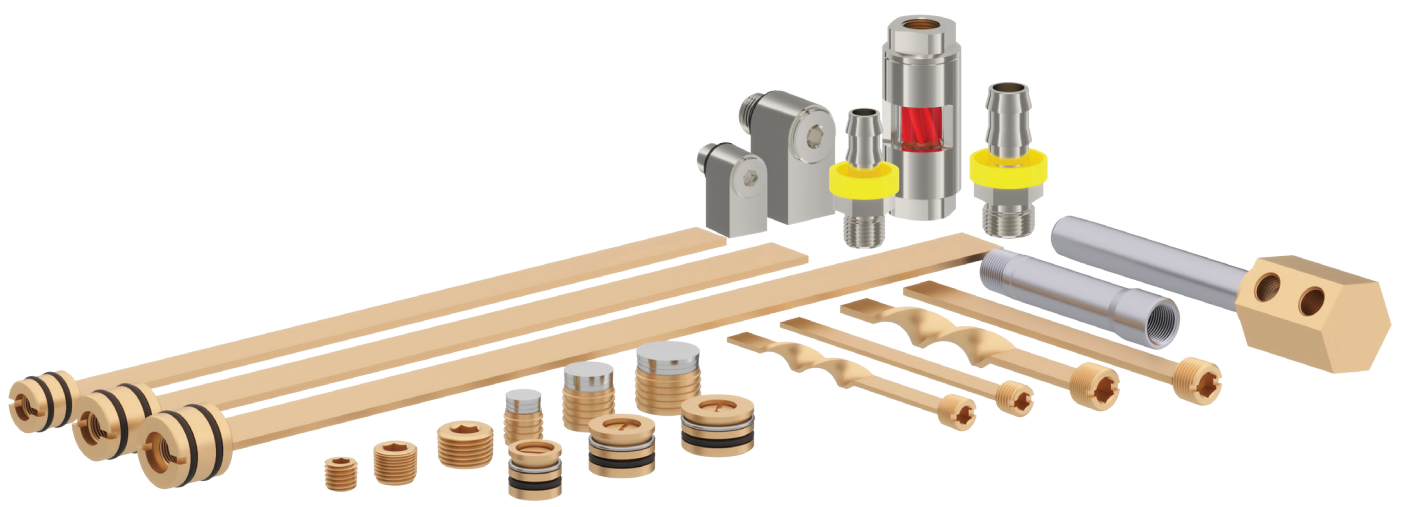

MOULD ACCESSORIES

Threadless Pressure Plug

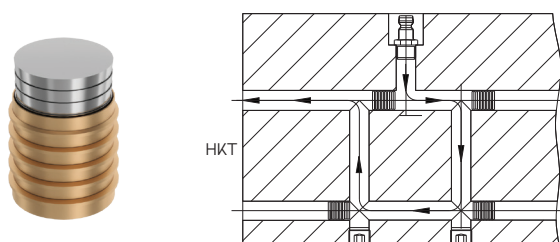

HKT

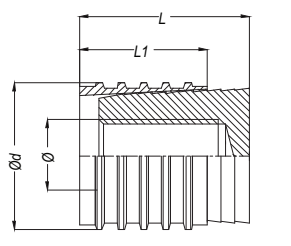

Part No.	Ø	Ød	L1	L
HKT - 06	M3	6	8.3	12
HKT - 08	M4	8	8.3	12
HKT - 10	M6	10	10.2	14.6
HKT - 11.5	M6	11.1	12.3	14.3
HKT - 12	M6	12	10.2	14.6
HKT - 14	M8	14	12.3	17
HKT - 15	M8	15	12.3	17
HKT - 16	M8	16	12.3	17
HKT - 20	M8	20	12.3	17

Threadless Pressure Plug

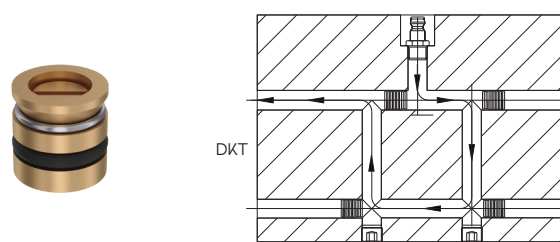

DKT

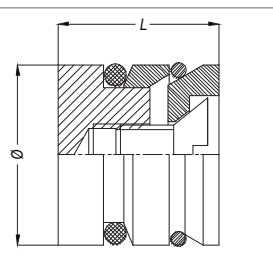

Part No.	Ø	L
DKT - 06	5.8	10
DKT - 07	6.8	10
DKT - 08	7.8	10
DKT - 8.5	8.3	10
DKT - 10	9.8	10
DKT - 11.5	11.3	10
DKT - 12	11.8	10
DKT - 14	13.8	12
DKT - 15	14.8	12
DKT - 16	15.8	12
DKT - 20	19.8	12
DKT - 22	21.8	12
DKT - 24	25.3	15.8
DKT - 28	27.8	20

Pressure Plugs

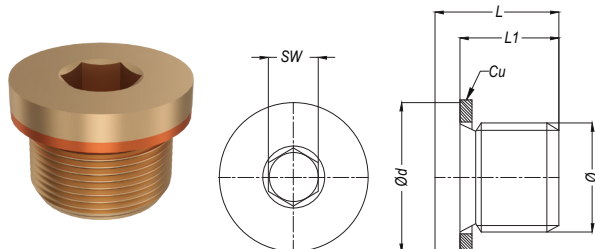

Part No.	Ø	Ød	L	L1	SW
KFR10	G 1/8"	14	11	8	5
KFR13	G 1/4"	18	15	12	6
KFR17	G 3/8"	22	15	12	8
KFR21	G 1/2"	26	18	14	10
KFR26	G 3/4"	32	20	15	12
KFR33	G 1"	39	21	16	17
KFM10	M10x1	14	11	8	5
KFM12	M12x1.5	17	15	12	6
KFM14	M14x1.5	19	15	12	6
KFM16	M16x1.5	21	15	12	8
KFM22	M22x1.5	27	18	14	10
KFM24	M24x1.5	30	18	14	12

Rotatable connector

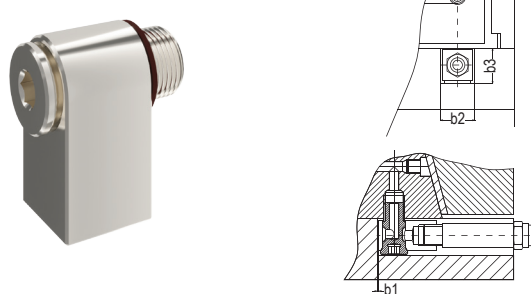

Part No.	b1	b2	b3
HDB10 G1/8"	1	16	17
HDM10 M10x1	1	16	17
HDB13 G1/4"	1	16	23
HDM14 M14x1.5	1	16	23
HDB21 G1/2"	1	16	35.5

MOULD ACCESSORIES

Deflection Baffles

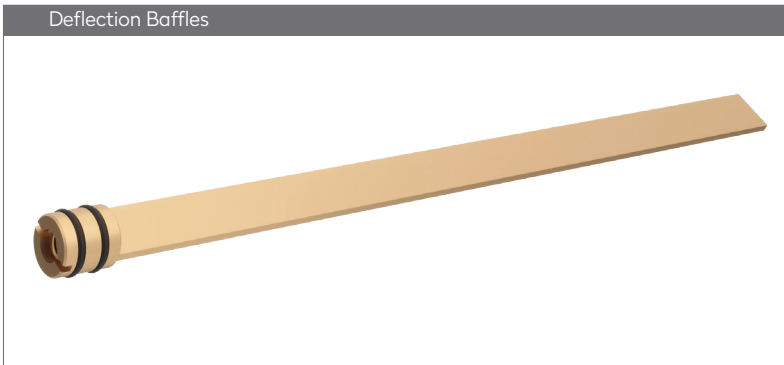

Part No.	Ød1	Ød2	Ø	Ød	L	L1	L2	S
LKS 10 x 180	10	12	M6x1	11.7	180	13	193	2
LKS 15 x 150	15	16	M8x1.25	15.7	250	16	266	2.4
LKS 20 x 300	20	22	M12x1.75	21.7	300	20	320	2.4
LKS 25 x 390	25	26	M16x2	25	390	22	412	2.4

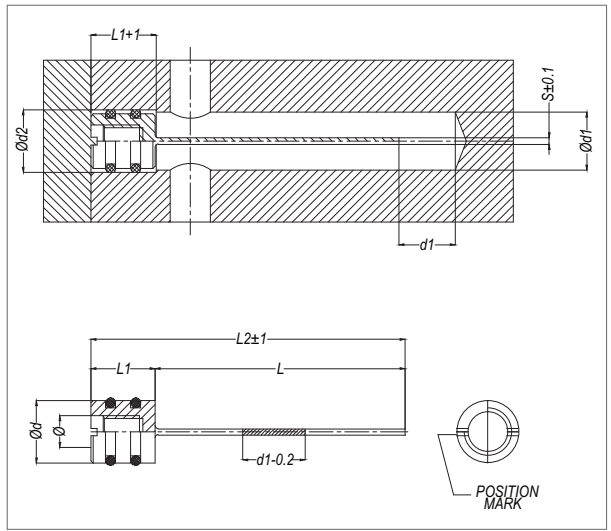

Deflection Baffles



Part No.	L	L1	L2	L3	L4	Ød	Ød1	Ød2	Ød3	Ød4	Ød5	S
BKS 10/2.6x0.3x100	100	16	9	3.5	2.5	2.6	4	10	2	4	2	0.3
BKS 10/2.6x0.3x200	200	16	9	3.5	2.5	2.6	4	10	2	4	2	0.3
BKS 10/3x0.3x100	100	16	9	3.5	2.5	3	5	10	2.4	4	2	0.3
BKS 10/3x0.3x200	200	16	9	3.5	2.5	3	5	10	2.4	4	2	0.3
BKS 10/4x0.5x100	100	16	9	3.5	2.5	4	6	10	3	4	2	0.5
BKS 10/4x0.5x200	200	16	9	3.5	2.5	4	6	10	3	4	2	0.5
BKS 12/5x0.5x160	160	18	9	4.5	2.5	5	8	12	4	6	2	0.5
BKS 12/5x0.5x315	315	18	9	4.5	2.5	5	8	12	4	6	2	0.5
BKS 16/6x0.5x160	160	18	9	6	2.5	6	12	16	5	6	2	0.5
BKS 16/6x0.5x315	315	18	9	6	2.5	6	12	16	5	6	2	0.5
BKS 18/8x1x160	160	18	9	7	2.5	8	14	18	6	6	2	1
BKS 18/8x1x315	315	18	9	7	2.5	8	14	18	6	6	2	1
BKS 20/10x1x160	160	20	10	8	2.5	10	16	20	8	8	3	1
BKS 20/10x1x315	315	20	10	8	2.5	10	16	20	8	8	3	1
BKS 25/12x1x160	160	25	13	9.5	3	12	20	25	10	10	3	1
BKS 25/12x1x315	315	25	13	9.5	3	12	20	25	10	10	3	1

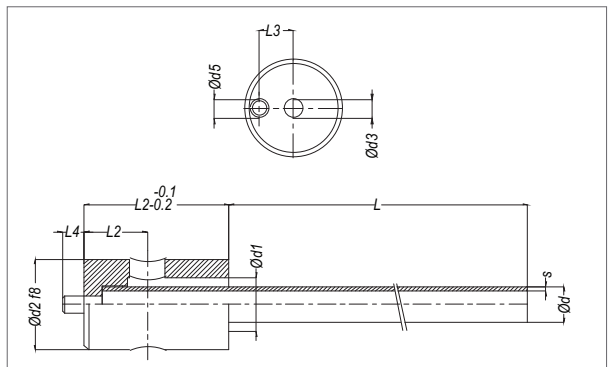

MOULD ACCESSORIES

Straight Baffles With

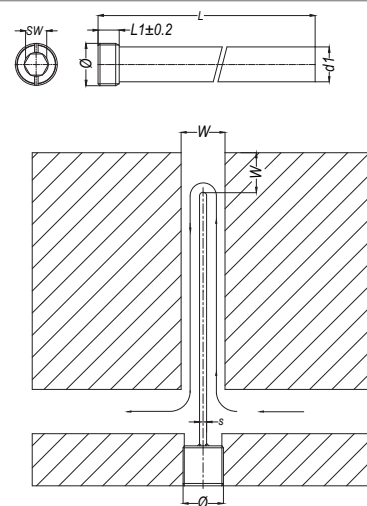
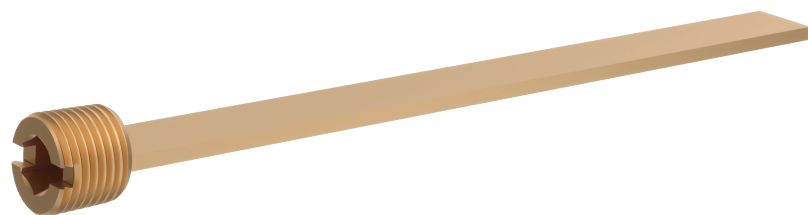

BSPT Thread (Conical 1/16) Part No.	BSP Thread (Cylindrical) Part No.	NPT Thread Part No.	Ø	SW	W	d1	L	L1 BDP	L1 GDP	L1 NDP	S Blade Thickness
BDP.100.08	GDP.100.08	NDP.100.08	1/16"	4	6.5	6.2	104	8	8	8	1.6
BDP.200.08	GDP.200.08	NDP.200.08	1/16"	4	6.5	6.2	204	8	8	8	1.6
BDP.100.10	GDP.100.10	NDP.100.10	1/8"	5	8.5	8.2	104	8	8	8	1.6
BDP.200.10	GDP.200.10	NDP.200.10	1/8"	5	8.5	8.2	204	8	8	8	1.6
BDP.125.13	GDP.125.13	NDP.125.13	1/4"	7	11.5	11.2	129	10	10	10	2.4
BDP.250.13	GDP.250.13	NDP.250.13	1/4"	7	11.5	11.2	254	10	10	10	2.4
BDP.150.17	GDP.150.17	NDP.150.17	3/8"	8	15	14.7	154	10	10	10	2.4
BDP.300.17	GDP.300.17	NDP.300.17	3/8"	8	15	14.7	304	10	10	10	2.4
BDP.200.21	GDP.200.21	NDP.200.21	1/2"	10	18.5	18.2	204	10	10	12	2.4
BDP.400.21	GDP.400.21	NDP.400.21	1/2"	10	18.5	18.2	404	10	10	12	2.4
BDP.300.26	GDP.300.26	NDP.300.26	3/4"	12	23.5	23.2	304	12	12	17	3.2
BDP.500.26	GDP.500.26	NDP.500.26	3/4"	12	23.5	23.2	504	12	12	17	3.2
BDP.400.33	GDP.400.33	NDP.400.33	1"	17	28.5	28.2	404	12	15	19	3.2
BDP.600.33	GDP.600.33	NDP.600.33	1"	17	28.5	28.2	604	12	15	19	3.2

Metric Thread (Conical 1/16) Part No.	Metric Thread (Cylindrical 1/16) Part No.	Ø	SW	W	d1	L MDPK	L MDP	L1	S Blade Thickness
MDPK.100.08	MDP.100.08	M8x0.75	4	6	5.8	102	104	8	1.6
MDPK.200.08	MDP.200.08	M8x0.75	4	6	5.8	202	204	8	1.6
MDPK.100.10	MDP.100.10	M10x1.0	5	8	7.8	102	104	8	1.6
MDPK.125.10	MDP.125.10	M10x1.0	5	8	7.8	127	129	8	1.6
MDPK.200.10	MDP.200.10	M10x1.0	5	8	7.8	202	204	8	1.6
MDPK.300.10	MDP.300.10	M10x1.0	5	8	7.8	302	304	8	1.6
MDPK.125.12	MDP.125.12	M12x1.5	6	10	9.8	127	129	8	2.0
MDPK.250.12	MDP.250.12	M12x1.5	6	10	9.8	252	254	8	2.0
MDPK.150.16	MDP.150.16	M16x1.5	8	14	13.8	154	154	10	2.4
MDPK.300.16	MDP.300.16	M16x1.5	8	14	13.8	304	304	10	2.4
MDPK.150.20	MDP.150.20	M20x1.5	10	18	17.8	154	154	10	2.4
MDPK.200.20	MDP.200.20	M20x1.5	10	18	17.8	304	304	10	2.4
MDPK.300.20	MDP.300.20	M20x1.5	10	18	17.8	204	204	10	2.4
MDPK.150.24	MDP.150.24	M24x1.5	12	20	19.8	154	154	12	2.4
MDPK.300.24	MDP.300.24	M24x1.5	12	20	19.8	304	304	12	2.4

MOULD ACCESSORIES

Spiral Blade Plug Baffles

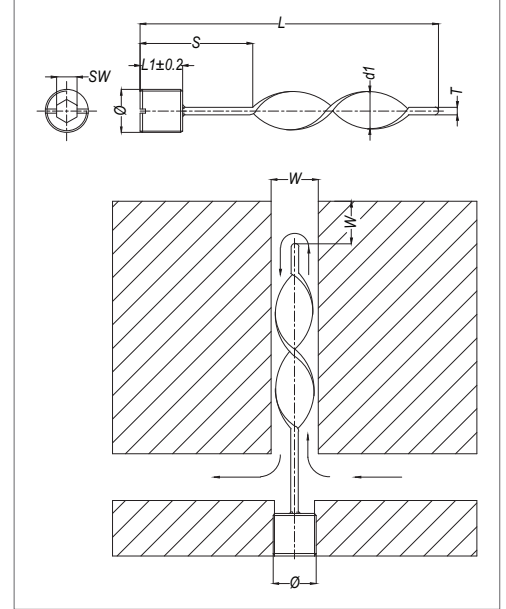
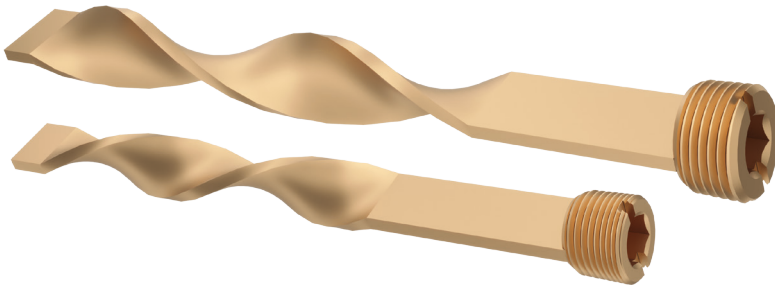

BSP Thread (Conical 1/16) Part No.	BSP Thread (Cylindrical) Part No.	NPT Thread (Conical 1/16) Part No.	Ø	S	SW	W BSP/BSP	W NPT	B BSP/BSP	B NPT	L	L1	L1 NPT	T Blade Thickness
BSP.100.08	GSP.100.08	NSP.100.08	1/16"	45	4	6.5	6.5	6.2	6.2	102	8	8	1.6
BSP.200.08	GSP.200.08	NSP.200.08	1/16"	102	4	6.5	6.5	6.2	6.2	202	8	8	1.6
BSP.100.10	GSP.100.10	NSP.100.10	1/8"	45	5	8.5	8.1	8.2	7.8	102	8	8	1.6
BSP.200.10	GSP.200.10	NSP.200.10	1/8"	102	5	8.5	8.1	8.2	7.8	202	8	8	1.6
BSP.125.13	GSP.125.13	NSP.125.13	1/4"	45	7	11.5	11.3	11.2	11	127	10	10	2.4
BSP.250.13	GSP.250.13	NSP.250.13	1/4"	102	7	11.5	11.3	11.2	11	252	10	10	2.4
BSP.150.17	GSP.150.17	NSP.150.17	3/8"	45	8	15	14.5	14.7	14.2	152	10	10	2.4
BSP.300.17	GSP.300.17	NSP.300.17	3/8"	102	8	15	14.5	14.7	14.2	302	10	10	2.4
BSP.200.21	GSP.200.21	NSP.200.21	1/2"	76	10	18.5	17.6	18.2	17.3	202	10	12	2.4
BSP.400.21	GSP.400.21	NSP.400.21	1/2"	127	10	18.5	17.6	18.2	17.3	402	10	12	2.4
BSP.300.26	GSP.300.26	NSP.300.26	3/4"	102	12	23.5	23.5	23.2	23.2	302	12	17	3.2
BSP.500.26	GSP.500.26	NSP.500.26	3/4"	153	12	23.5	23.5	23.2	23.2	502	12	17	3.2
BSP.400.33	GSP.400.33	NSP.400.33	1"	127	17	28.5	28.9	28.2	28.2	402	12	19	3.2
BSP.600.33	GSP.600.33	NSP.600.33	1"	203	17	28.5	28.9	28.2	28.2	602	12	19	3.2

Metric Thread (Conical 1/16) Part No.	Metric Thread (Cylindrical) Part No.	Ø	S	SW	W	B	L	L1	T Blade Thickness	T MSPK	T MSP
MSPK.100.08	MSP.100.08	M8x0.75	45	4	6	5.8	102	8	1.6	1.6	2
MSPK.200.08	MSP.200.08	M8x0.75	100	4	6	5.8	202	8	1.6	1.6	2
MSPK.300.08	MSP.300.08	M8x0.75	150	4	6	5.8	302	8	1.6	1.6	2
MSPK.100.10	MSP.100.10	M10x1.0	45	5	8	7.8	102	8	1.6	1.6	2
MSPK.100.10x1.5	MSP.100.10x1.5	M10x1.5	45	5	8	7.8	102	8	1.6	1.6	2
MSPK.200.10	MSP.200.10	M10x1.0	100	5	8	7.8	202	8	1.6	1.6	2
MSPK.300.10	MSP.300.10	M10x1.0	150	5	8	7.8	302	8	1.6	1.6	2
MSPK.125.12	MSP.125.12	M12x1.5	45	6	10	9.8	127	8	2.0	2.0	2.4
MSPK.125.12x1.75	MSP.125.12x1.75	M12x1.75	45	6	10	9.8	127	8	2.0	2.0	2.4
MSPK.250.12	MSP.250.12	M12x1.5	100	6	10	9.8	252	8	2.0	2.0	2.4
MSPK.150.16	MSP.150.16	M16x1.5	45	8	14	13.8	152	10	2.4	2.4	2.4
MSPK.300.16	MSP.300.16	M16x1.5	100	8	14	13.8	302	10	2.4	2.4	2.4
MSPK.150.20	MSP.150.20	M20x1.5	45	10	18	17.8	152	10	2.4	2.4	2.4
MSPK.300.20	MSP.300.20	M20x1.5	100	10	18	17.8	302	10	2.4	2.4	2.4
MSPK.150.24	MSP.150.24	M24x2.0	45	12	20	19.8	152	12	2.5	2.4	3.2
MSPK.300.24	MSP.300.24	M24x2.0	100	12	20	19.8	302	12	2.5	2.4	3.2

MOULD ACCESSORIES

BVS / BLS Cascade

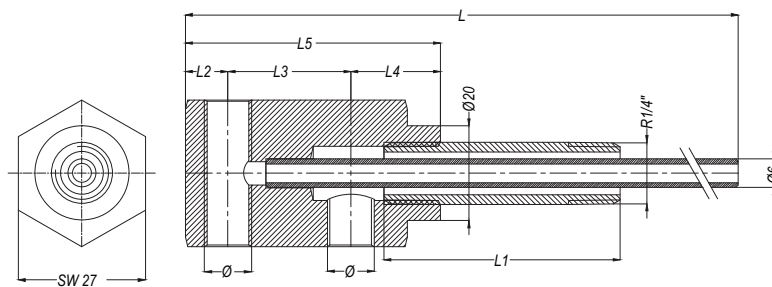

Part No.	Rp	L2	L3	L4	L5	L	L1
BVS 10x50	BSP 1/8"	9	19	9	42	356	50
BVS 10x100	BSP 1/8"	9	19	9	42	356	100
BVS 10x150	BSP 1/8"	9	19	9	42	356	150
BVS 10x200	BSP 1/8"	9	19	9	42	356	200
BVS 13x50	BSP 1/4"	9	19	9	42	356	50
BVS 13x100	BSP 1/4"	9	19	9	42	356	100
BVS 13x150	BSP 1/4"	9	19	9	42	356	150
BVS 13x200	BSP 1/4"	9	19	9	42	356	200

Part No.	Rp	L2	L3	L4	L5	L	L1
BLS 10x50	BSP 1/8"	9	26	12	54	362	50
BLS 10x100	BSP 1/8"	9	26	12	54	362	100
BLS 10x150	BSP 1/8"	9	26	12	54	362	150
BLS 10x200	BSP 1/8"	9	26	12	54	362	200
BLS 13x50	BSP 1/4"	9	26	12	54	362	50
BLS 13x100	BSP 1/4"	9	26	12	54	362	100
BLS 13x150	BSP 1/4"	9	26	12	54	362	150
BLS 13x200	BSP 1/4"	9	26	12	54	362	200

PRESSURE PLUGS

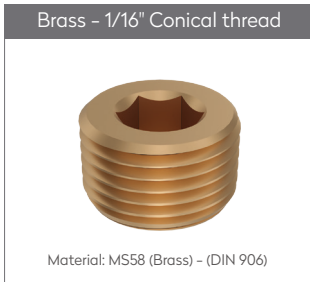

BSPT PRESSURE PLUGS VERSCHLUSSSTOPFEN MIT BSPT

Part No.	Ø	L	SW
KTR 10	BSPT 1/8"	8	5
KTR 13	BSPT 1/4"	10	7
KTR 17	BSPT 3/8"	10	8
KTR 21	BSPT 1/2"	10	10
KTR 26	BSPT 3/4"	12	12
KTR 33	BSPT 1"	12	17
KTR 42	BSPT 1 1/4"	18	22
KTR 48	BSPT 1 1/2"	20	24

Part No.	Ø	L	SW
KTR 10-C	BSPT 1/8"	8	5
KTR 13-C	BSPT 1/4"	10	6
KTR 17-C	BSPT 3/8"	11	8
KTR 21-C	BSPT 1/2"	13	10
KTR 26-C	BSPT 3/4"	17	12
KTR 33-C	BSPT 1"	19	17
KTR 42-C	BSPT 1 1/4"	22	22
KTR 48-C	BSPT 1 1/2"	22	24

Part No.	Ø	L	SW
KTR 10-S3	BSPT 1/8"	8	5
KTR 13-S3	BSPT 1/4"	10	7
KTR 17-S3	BSPT 3/8"	10	8
KTR 21-S3	BSPT 1/2"	10	10
KTR 26-S3	BSPT 3/4"	12	12
KTR 33-S3	BSPT 1"	12	17
KTR 42-S3	BSPT 1 1/4"	18	22
KTR 48-S3	BSPT 1 1/2"	20	24

NPT PRESSURE PLUGS VERSCHLUSSSTOPFEN MIT NPT

Part No.	Ø	L	SW
KTN 10	NPT 1/8"	8	5
KTN 13	NPT 1/4"	10	7
KTN 17	NPT 3/8"	10	8
KTN 21	NPT 1/2"	12	10
KTN 26	NPT 3/4"	17	12
KTN 33	NPT 1"	19	17
KTN 42	NPT 1 1/4"	22	22
KTN 48	NPT 1 1/2"	22	24

Part No.	Ø	L	SW
KTN 10-C	NPT 1/8"	8	5
KTN 13-C	NPT 1/4"	10	6
KTN 17-C	NPT 3/8"	10	8
KTN 21-C	NPT 1/2"	12	10
KTN 26-C	NPT 3/4"	17	12
KTN 33-C	NPT 1"	19	17
KTN 42-C	NPT 1 1/4"	22	22
KTN 48-C	NPT 1 1/2"	22	24

Part No.	Ø	L	SW
KTN 10-S3	NPT 1/8"	8	5
KTN 13-S3	NPT 1/4"	10	6
KTN 17-S3	NPT 3/8"	10	8
KTN 21-S3	NPT 1/2"	12	10
KTN 26-S3	NPT 3/4"	17	12
KTN 33-S3	NPT 1"	19	17
KTN 42-S3	NPT 1 1/4"	22	22
KTN 48-S3	NPT 1 1/2"	22	24

METRIC PRESSURE PLUGS VERSCHLUSSSTOPFEN MIT GEWINDE

Part No.	Ø	L	SW
KTM 10	M 10 x 1	8	5
KTM 12	M 12 x 1.5	8	6
KTM 14	M 14 x 1.5	10	7
KTM 16	M 16 x 1.5	10	8
KTM 18	M 18 x 1.5	10	8
KTM 20	M 20 x 1.5	10	10
KTM 22	M 22 x 1.5	10	10
KTM 24	M 24 x 1.5	12	12

Part No.	Ø	L	SW
KTM 10-C	M 10 x 1	8	5
KTM 12-C	M 12 x 1.5	8	6
KTM 14-C	M 14 x 1.5	10	6
KTM 16-C	M 16 x 1.5	10	8
KTM 18-C	M 18 x 1.5	10	8
KTM 20-C	M 20 x 1.5	10	10
KTM 22-C	M 22 x 1.5	10	10
KTM 24-C	M 24 x 1.5	12	12

Part No.	Ø	L	SW
KTM 10-S3	M 10 x 1	8	5
KTM 12-S3	M 12 x 1.5	8	6
KTM 14-S3	M 14 x 1.5	10	7
KTM 16-S3	M 16 x 1.5	10	8
KTM 18-S3	M 18 x 1.5	10	8
KTM 20-S3	M 20 x 1.5	10	10
KTM 22-S3	M 22 x 1.5	10	10
KTM 24-S3	M 24 x 1.5	12	12

PRESSURE PLUGS

BSP PRESSURE PLUGS VERSCHLUSSTOPFEN MIT BSP

Brass - 1/16" Cylindrical thread

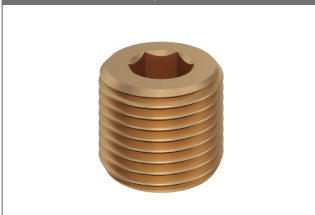

Steel - 1/16" Cylindrical thread



Stainless Steel-1/16" Cylindrical thread

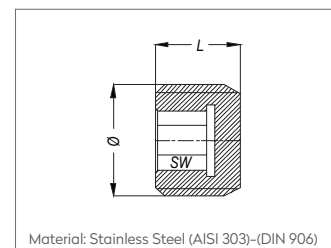
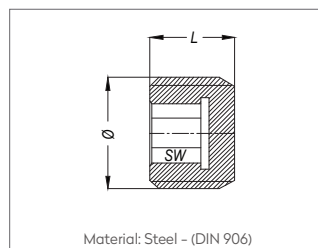
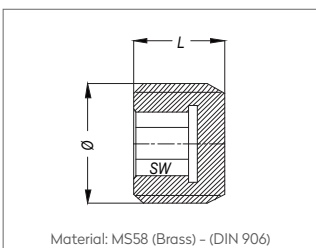

Part No.	Ø	L	SW
KTR 10D	BSP 1/8"	8	5
KTR 13D	BSP 1/4"	10	7
KTR 17D	BSP 3/8"	10	8
KTR 21D	BSP 1/2"	10	10
KTR 26D	BSP 3/4"	12	12
KTR 33D	BSP 1"	15	14

Part No.	Ø	L	SW
KTR 10D-C	BSP 1/8"	8	5
KTR 13D-C	BSP 1/4"	10	7
KTR 17D-C	BSP 3/8"	10	8
KTR 21D-C	BSP 1/2"	10	10
KTR 26D-C	BSP 3/4"	12	12
KTR 33D-C	BSP 1"	15	14

Part No.	Ø	L	SW
KTR 10D-S3	BSP 1/8"	8	5
KTR 13D-S3	BSP 1/4"	10	7
KTR 17D-S3	BSP 3/8"	10	8
KTR 21D-S3	BSP 1/2"	10	10
KTR 26D-S3	BSP 3/4"	12	12
KTR 33D-S3	BSP 1"	15	14

METRIC PRESSURE PLUGS VERSCHLUSSTOPFEN MIT GEWINDE

Part No.	Ø	L	SW
KTM 10D	M 10 x 1	8	5
KTM 12D	M 12 x 1.5	8	6
KTM 14D	M 14 x 1.5	10	7
KTM 16D	M 16 x 1.5	10	8
KTM 18D	M 18 x 1.5	10	8
KTM 20D	M 20 x 1.5	10	10
KTM 22D	M 22 x 1.5	10	10
KTM 24D	M 24 x 1.5	12	12

Part No.	Ø	L	SW
KTM 10D-C	M 10 x 1	8	5
KTM 12D-C	M 12 x 1.5	8	6
KTM 14D-C	M 14 x 1.5	10	7
KTM 16D-C	M 16 x 1.5	10	8
KTM 18D-C	M 18 x 1.5	10	8
KTM 20D-C	M 20 x 1.5	10	10
KTM 22D-C	M 22 x 1.5	10	10
KTM 24D-C	M 24 x 1.5	12	12

Part No.	Ø	L	SW
KTM 10D-S3	M 10 x 1	8	5
KTM 12D-S3	M 12 x 1.5	8	6
KTM 14D-S3	M 14 x 1.5	10	7
KTM 16D-S3	M 16 x 1.5	10	8
KTM 18D-S3	M 18 x 1.5	10	8
KTM 20D-S3	M 20 x 1.5	10	10
KTM 22D-S3	M 22 x 1.5	10	10
KTM 24D-S3	M 24 x 1.5	12	12

ADAPTERS

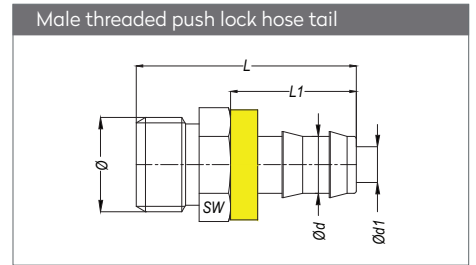
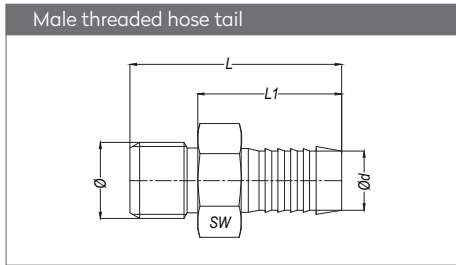
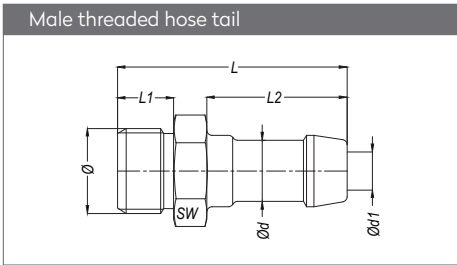
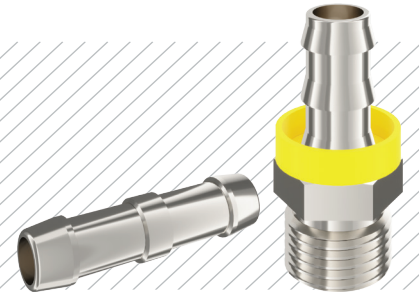

Part No.	Ø	Ød	d1	L	L1	L2	SW
TAF 10.04	BSP 1/8"	4	3	43	8	27.5	14
TAF 10.06	BSP 1/8"	6	4	43	8	27.5	14
TAF 10.08	BSP 1/8"	8	5.5	43	8	27.5	14
TAF 10.10	BSP 1/8"	10	5.5	43	8	27.5	14
TAF 13.06	BSP 1/4"	6	4	45	11	27.5	17
TAF 13.08	BSP 1/4"	8	5.5	45	11	27.5	17
TAF 13.09	BSP 1/4"	9	6	45	11	27.5	17
TAF 13.10	BSP 1/4"	10	7	45	11	27.5	17
TAF 13.12	BSP 1/4"	12	7.5	45	11	27.5	17
TAF 17.08	BSP 3/8"	8	5.5	45	11	27.5	19
TAF 17.10	BSP 3/8"	10	7	45	11	27.5	19
TAF 17.13	BSP 3/8"	13	9	52	11	33	19
TAF 17.16	BSP 3/8"	16	11	52	11	33	22
TAF 21.13	BSP 1/2"	13	9	54	14	33	22
TAF 21.16	BSP 1/2"	16	11	54	14	33	22
TAF 26.16	BSP 3/4"	16	11	58	16	33	30
TAF 26.19	BSP 3/4"	19	14	58	16	33	30

Part No.	Ø	Ød1	L	L1	SW
EFH 10-06	BSP 1/8"	Ø6	35	28	11
EFH 10-08	BSP 1/8"	Ø8	35	28	11
EFH 10-10	BSP 1/8"	Ø10	35	28	12
EFH 13-06	BSP 1/4"	Ø6	38	29	15
EFH 13-08	BSP 1/4"	Ø8	38	29	15
EFH 13-10	BSP 1/4"	Ø10	38	29	15
EFH 13-13	BSP 1/4"	Ø13	38	29	15
EFH 17-08	BSP 3/8"	Ø8	38	29	17
EFH 17-10	BSP 3/8"	Ø10	38	29	17
EFH 17-13	BSP 3/8"	Ø13	38	29	17
EFH 17-16	BSP 3/8"	Ø16	39	30	19
EFH 21-10	BSP 1/2"	Ø10	43	31	22
EFH 21-13	BSP 1/2"	Ø13	43	31	22
EFH 21-16	BSP 1/2"	Ø16	43	31	22
EFH 21-19	BSP 1/2"	Ø19	43	31	22
EFH 26-16	BSP 3/4"	Ø16	50	34	27
EFH 26-19	BSP 3/4"	Ø19	50	34	27
EFH 33-19	BSP 1"	Ø19	53	34	36
EFH 33-25	BSP 1"	Ø25	53	34	36

Part No.	Ø	Ød	Ød1	L	L1	SW
EHF 13-08	BSP 1/4"	Ø8	5.5	41	24	17
EHF 13-10	BSP 1/4"	Ø10	7.5	41	24	17
EHF 13-13	BSP 1/4"	Ø12.7	9	45	28	17
EHF 17-13	BSP 3/8"	Ø12.7	10	45	28	19
EHF 17-16	BSP 3/8"	Ø16	12	58	38	19
EHF 21-13	BSP 1/2"	Ø12.7	10	49	28	22
EHF 21-16	BSP 1/2"	Ø16	13	60	38	22
EHF 26-16	BSP 3/4"	Ø16	13	63	38	30

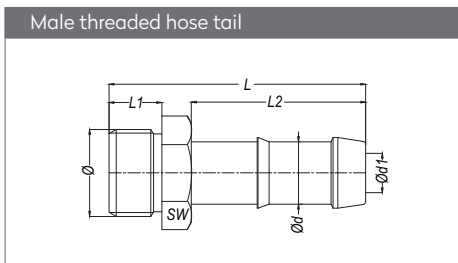

Part No.	Ø	Ød	d1	L	L1	L2	SW
EHL 17.13	BSP 3/8"	13	9	72	12	53	19
EHL 17.16	BSP 3/8"	16	11	72	12	53	22
EHL 21.13	BSP 1/2"	13	9	74	14	53	22
EHL 21.16	BSP 1/2"	16	11	74	14	53	22
EHL 21.19	BSP 1/2"	19	11	74	14	53	22
EHL 26.19	BSP 3/4"	19	15	78	16	53	30
EHL 26.25	BSP 3/4"	25	19	80	16	53	35
EHL 33.19	BSP 1"	19	15	84	20	53	36
EHL 33.25	BSP 1"	25	19	84	20	53	36

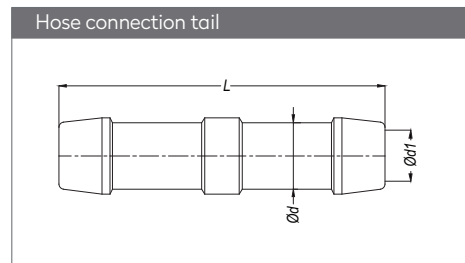

Part No.	Ød	Ød1	L
UHU 04	4	3	52
UHU 06	6	4	52
UHU 08	8	6	52
UHU 09	9	7	52
UHU 10	10	8	52
UHU 13	13	10	64
UHU 16	16	12	64
UHU 19	19	15	64
UHU 23	23	19	64

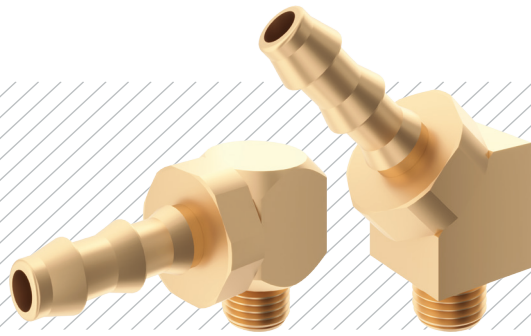

ADAPTERS

Male threaded hose tail 45°

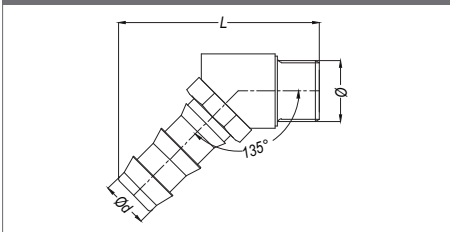

Part No.	Ø	Ød	L
AHF10-06-45	BSP 1/8"	6.7	42
AHF10-08-45	BSP 1/8"	8	42
AHF10-09-45	BSP 1/8"	9	42
AHF10-10-45	BSP 1/8"	10	42
AHF13-06-45	BSP 1/4"	6.7	43.4
AHF13-08-45	BSP 1/4"	8	43.4
AHF13-09-45	BSP 1/4"	9	43.4
AHF13-10-45	BSP 1/4"	10	43.4

Male threaded hose tail 90°

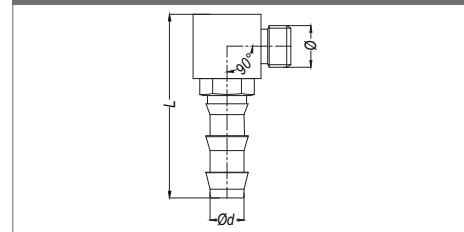

Part No.	Ø	Ød	L
AHF10-06-90	BSP 1/8"	6.7	43
AHF10-08-90	BSP 1/8"	8	43
AHF10-09-90	BSP 1/8"	9	43
AHF10-10-90	BSP 1/8"	10	43
AHF13-06-90	BSP 1/4"	6.7	48
AHF13-08-90	BSP 1/4"	8	48
AHF13-09-90	BSP 1/4"	9	48
AHF13-10-90	BSP 1/4"	10	48

Male threaded hose tail

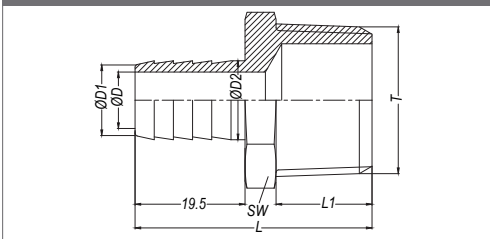

Part No.	Ø	Ød	Ød1	Ød2	L	L1	SW
EFR 10-06	BSPT 1/8"	4	5.5	6	34	9	10
EFR 13-06	BSPT 1/4"	4	5.5	9	37	12	14
EFR 13-10	BSPT 1/4"	8	9.5	9	37	12	14
EFR 17-10	BSPT 3/8"	8	9.5	12	37	12	17
EFR 17-13	BSPT 3/8"	10	12.5	12	37	12	17
EFR 17-16	BSPT 3/8"	12	15.5	12	40	13	17
EFR 21-10	BSPT 1/2"	8	9.5	14	44	17	21
EFR 21-13	BSPT 1/2"	10	12.5	14	44	17	21
EFR 26-10	BSPT 3/4"	8	9.5	20	46.5	17	27
EFR 26-19	BSPT 3/4"	15	18.5	20	47.5	18	27
EFR 26-25	BSPT 3/4"	19	24.5	19	47.5	18	27
EFR 33-13	BSPT 1"	10	12.5	22.5	52.5	23	34
EFR 33-19	BSPT 1"	15	18.5	22.5	52.5	23	34
EFR 48-32	BSPT 1 1/2"	26	31.5	35	58	24	50
EFR 48-38	BSPT 1 1/2"	30	37.5	35	58	24	50

Male threaded hose tail

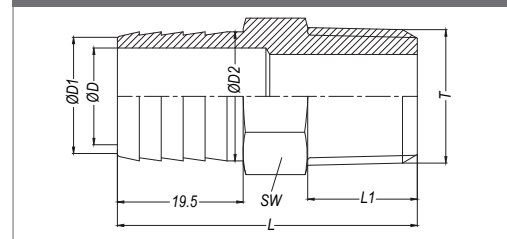

Part No.	Ø	Ød	Ød1	Ød2	L	L1	SW
EFR 10-10	BSPT 1/8"	8	9.5	6	34	9	12
EFR 13-13	BSPT 1/4"	10	12.5	9	37	12	14
EFR 17-19	BSPT 3/8"	15	18.5	12	42.5	13	21
EFR 21-19	BSPT 1/2"	15	18.5	14	46.5	17	21
EFR 21-25	BSPT 1/2"	19	24.5	14	46.5	17	27

HOSES

SCHLÄUCHE

PLOK HOSES

Structure: NBR hose with reinforcement is kink resistant and flexible for hot and cold water.
No need to use clamps in combination with pushlock hose plug.

Struktur: NBR Schläuche mit Polyesterbewegung sind knickbeständig, biegsam und in Kalt- und Heisswasser einsetzbar. In Verbindung mit Schnellsteck - Schlauchtülle sind keine Schlauchschellen notwendig.

Working Temperature Range
-20°C to + 90°C

Rolls of 12m and 15m are also available upon request.

Betriebstemperaturbereich
-20°C to + 90°C

12m und 15m Rollen sind auch lieferbar auf Anfrage.

Part No.	Internal Dia.		Outside Dia mm	Max. Working Pressure at 20°C Bar	Bursting Pressure at 20°C Bar	Length	Weight kg/m	Min. bend radius mm	Color
	mm	Inch.							
PLOK - 10B	9.5	3/8"	15.5	28	112	20	0.11	65	Blue
PLOK - 10R	9.5	3/8"	15.5	28	112	20	0.11	65	Red
PLOK - 12B	12.7	1/2"	19.5	28	112	20	0.15	80	Blue
PLOK - 12R	12.7	1/2"	19.5	28	112	20	0.15	80	Red
PLOK - 12S	12.7	1/2"	19.5	28	112	20	0.15	80	Black



PDLOK HOSES

→ Hoses functionally works by pushing and locking for 90°C - with smooth surface

→ Steckschlauch für 90°C - mit glatter Oberfläche

Structure: NBR hose with polyester reinforcement is kink resistant and flexible for hot and cold water. No need to use clamps in combination with pushlock hose plug.

Struktur: NBR Schläuche mit Polyesterbewegung sind knickbeständig, biegsam und in Kalt- und Heisswasser einsetzbar. In Verbindung mit Schnellsteck - Schlauchtülle sind keine Schlauchschellen notwendig.

Working Temperature Range
Static conditions: -20°C to +90°C

Betriebstemperaturbereich
Statische Bedingungen: -20°C to +90°C

→ Rolls of 12m and 15m are also available upon request.

→ 12m und 15m Rollen sind auch lieferbar auf Anfrage.

Part No.	Internal Dia.		Outside Dia mm	Max. Working Pressure 20°C Bar	Bursting Pressure 20°C Bar	Length	Weight kg/m	Min. Bending Radius mm	color
	mm	Inch.							
PDLOK - 06B	6.3	1/4"	12.3	28	112	20	0.11	65	Blue
PDLOK - 06R	6.3	1/4"	12.3	28	112	20	0.11	65	Red
PDLOK - 06S	6.3	1/4"	12.3	28	112	20	0.11	65	Black
PDLOK - 10B	9.5	3/8"	15.5	28	112	20	0.15	80	Blue
PDLOK - 10R	9.5	3/8"	15.5	28	112	20	0.15	80	Red
PDLOK - 10S	9.5	3/8"	15.5	28	112	20	0.15	80	Black
PDLOK - 12B	12.7	1/2"	19.5	28	112	20	0.22	100	Blue
PDLOK - 12R	12.7	1/2"	19.5	28	112	20	0.22	100	Red
PDLOK - 12S	12.7	1/2"	19.5	28	112	20	0.22	100	Black
PDLOK - 12G	12.7	1/2"	19.5	28	112	20	0.22	100	Green
PDLOK - 16B	16	5/8"	22.6	24	96	20	0.26	125	Blue
PDLOK - 16R	16	5/8"	22.6	24	96	20	0.26	125	Red
PDLOK - 16S	16	5/8"	22.6	24	96	20	0.26	125	Black
PDLOK - 19B	19	3/4"	25.8	20	84	20	0.28	150	Blue
PDLOK - 19R	19	3/4"	25.8	20	84	20	0.28	150	Red
PDLOK - 19S	19	3/4"	25.8	20	84	20	0.28	150	Black
PDLOK - 25B	25.4	1"	33.2	20	80	20	0.40	170	Blue
PDLOK - 25R	25.4	1"	33.2	20	80	20	0.40	170	Red

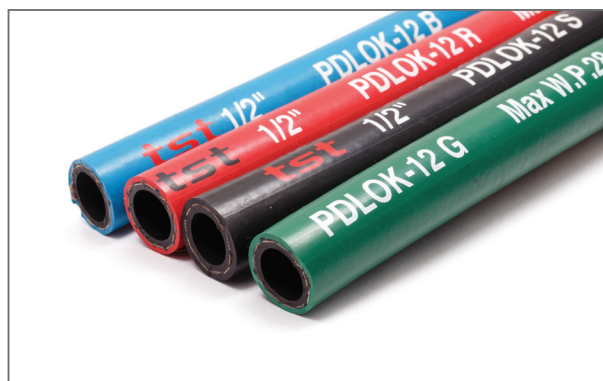

HOSES

SCHLÄUCHE

WHMLOK HOSES

→ Hoses functionally works by pushing and locking for 130°C - with **rough** surface

→ Steckschlauch für 130°C - mit rauher Oberfläche

Structure: EPDM hose with polyester reinforcement is kink resistant and flexible for hot and cold water. No need to use clamps in combination with pushlock hose plug.

Struktur: EPDM Schläuche mit Polyesterbewebung sind knickbeständig, biegsam und in Kalt- und Heisswasser einsetzbar. In Verbindung mit Schnellsteck - Schlauchtülle sind keine Schlauchschellen notwendig.

Conditions Temperature Range
-40°C to+ 130°C

Intermittent Working Temperature
Up to + 140°C

→ Rolls of 12m and 15m are also available upon request.

→ 12m und 15m Rollen sind auch lieferbar auf Anfrage.

Part No.	Internal Dia.		Outside Dia mm	Max. Working Pressure at 20°C Bar	Bursting Pressure at 20°C Bar	Length	Weight kg/m	Min. bend radius mm	Color
	mm	Inch.							
WHMLOK - 10B	9.5	3/8"	15.5	28	112	20	0.15	80	Blue
WHMLOK - 10R	9.5	3/8"	15.5	28	112	20	0.15	80	Red
WHMLOK - 12B	12.7	1/2"	19.5	28	112	20	0.22	100	Blue
WHMLOK - 12R	12.7	1/2"	19.5	28	112	20	0.22	100	Red



WHMDLOK HOSES

→ Hoses functionally works by pushing and locking for 130°C - with **smooth** surface

→ Steckschlauch für 130°C - mit glatter Oberfläche

Structure: EPDM hose with polyester reinforcement is kink resistant and flexible for hot and cold water. No need to use clamps in combination with pushlock hose plug.

Struktur: EPDM Schläuche mit Polyesterbewegung sind knickbeständig, biegsam und in Kalt- und Heisswasser einsetzbar. In Verbindung mit Schnellsteck - Schlauchtülle sind keine Schlauchschellen notwendig.

Conditions Temperature Range

-40°C to + 130°C

Intermittent Working Temperature

Up to + 140°C

→ Rolls of 12m and 15m are also available upon request.

→ 12m und 15m Rollen sind auch lieferbar auf Anfrage.

Part No.	Internal Dia.		Outside Dia mm	Max. Working Pressure at 20°C Bar	Bursting Pressure at 20°C Bar	Lenght	Weight kg/m	Min. bend radius mm	color
	mm	Inch.							
WHMDLOK - 06B	6.4	1/4"	12.3	28	112	20	0.1	65	Blue
WHMDLOK - 06R	6.4	1/4"	12.3	28	112	20	0.1	65	Red
WHMDLOK - 06S	6.4	1/4"	12.3	28	112	20	0.1	65	Black
WHMDLOK - 10B	9.5	3/8"	15.5	28	112	20	0.14	80	Blue
WHMDLOK - 10R	9.5	3/8"	15.5	28	112	20	0.14	80	Red
WHMDLOK - 10S	9.5	3/8"	15.5	28	112	20	0.14	80	Black
WHMDLOK - 12B	12.7	1/2"	19.5	28	112	20	0.2	100	Blue
WHMDLOK - 12R	12.7	1/2"	19.5	28	112	20	0.2	100	Red
WHMDLOK - 12S	12.7	1/2"	19.5	28	112	20	0.2	100	Black
WHMDLOK - 16B	15.9	5/8"	22.6	24	96	20	0.23	125	Blue
WHMDLOK - 16R	15.9	5/8"	22.6	24	96	20	0.23	125	Red
WHMDLOK - 16S	15.9	5/8"	22.6	24	96	20	0.23	125	Black
WHMDLOK - 19B	19	3/4"	25.8	21	84	20	0.28	150	Blue
WHMDLOK - 19R	19	3/4"	25.8	21	84	20	0.28	150	Red
WHMDLOK - 19S	19	3/4"	25.8	21	84	20	0.28	150	Black
WHMDLOK - 25B	25.4	1"	33.2	20	80	20	0.40	170	Blue
WHMDLOK - 25R	25.4	1"	33.2	20	80	20	0.40	170	Red
WHMDLOK - 25S	25.4	1"	33.2	20	80	20	0.40	170	Black



HOSES

SCHLÄUCHE

WRH HOSES

Structure: Medium pressure water hose with special mixture of powder rubber, kink resistant smooth outside and abrasion resistant. Available in black, red, blue and yellow covers.

Struktur: Mitteldruck Wasserschlauch mit Kautschuk ist knickbeständig, mit glatter Fläche und abnutzungswiderständig. Lieferbar in schwarzer, roter, blauer, und gelber Farbe.

Working Temperature Range

-10°C to + 60°C

+ 14°F to + 140°F

Betriebstemperaturbereich

-10°C to + 60°C

+ 14°F to + 140°F

Part No.	Internal Dia.		Outside Dia mm	Max. Working Pressure at 20°C Bar	Bursting Pressure at 20°C Bar	Length	Color
	mm	Inch.					
WRH - 08B	10	3/8"	16	10	30	100	Blue
WRH - 08R	10	3/8"	16	10	30	100	Red
WRH - 08S	10	3/8"	16	10	30	100	Black
WRH - 10B	12.5	1/2"	18	10	30	100	Blue
WRH - 10R	12.5	1/2"	18	10	30	100	Red
WRH - 10S	12.5	1/2"	18	10	30	100	Black
WRH - 13B	16	5/8"	22	10	30	100	Blue
WRH - 13R	16	5/8"	22	10	30	100	Red
WRH - 13S	16	5/8"	22	10	30	100	Black
WRH - 19B	19	3/4"	26	10	30	100	Blue
WRH - 19R	19	3/4"	26	10	30	100	Red
WRH - 19S	19	3/4"	26	10	30	100	Black
WRH - 25B	25	1"	33	10	30	100	Blue
WRH - 25R	25	1"	33	10	30	100	Red
WRH - 25S	25	1"	33	10	30	100	Black



NLH HOSES

Structure: PVC hose with polyester reinforcement kink resistant and flexible.

Struktur: PVC Schläuche mit Polyesterbewehrung, ist knickbeständig und biegsam.

Working Temperature Range

- 5°C to + 50°C

Betriebstemperaturbereich

- 5°C to + 50°C

Part No.	Internal Dia.		Outside Dia mm	Max. Working Pressure at 20°C Bar	Bursting Pressure at 20°C Bar	Color
	mm	Inch.				
NLH - 10B	10	3/8"	14.6	5	15	Blue
NLH - 10R	10	3/8"	16	20	60	Red
NLH - 13B	12.5	1/2"	16.5	5	15	Blue
NLH - 13R	12.5	1/2"	19	16	48	Red
NLH - 16B	16	5/8"	20.3	5	15	Blue
NLH - 16R	16	5/8"	22	16	48	Red
NLH - 19B	19	3/4"	23.5	5	15	Blue
NLH - 19R	19	3/4"	26	14	42	Red
NLH - 25B	25	1"	30.5	4	12	Blue
NLH - 25R	25	1"	33	10	30	Red

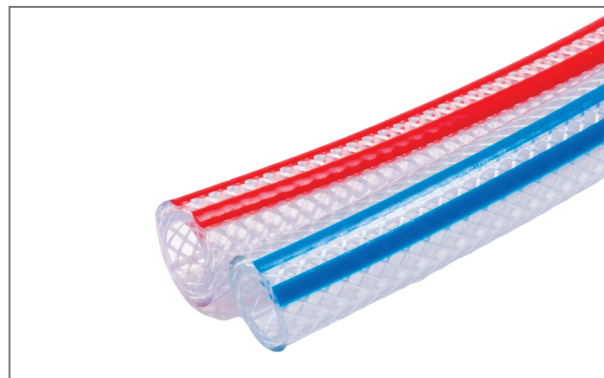

PUSH TO LOCK - HOSE ASSEMBLY TOOL

SCHLAUCH-MONTAGEWERKZEUG

SERIE HTA 10-13

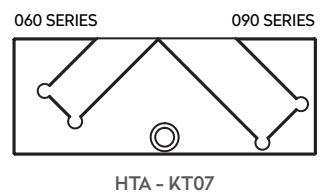
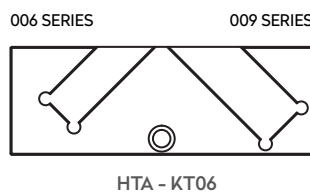
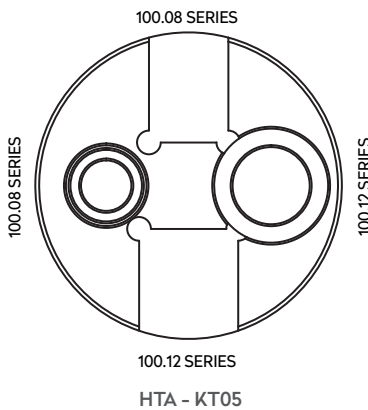
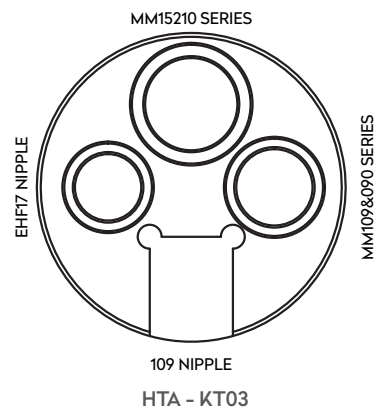
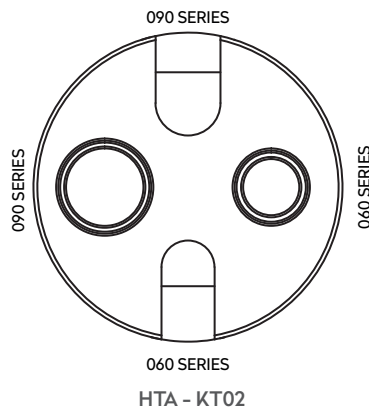
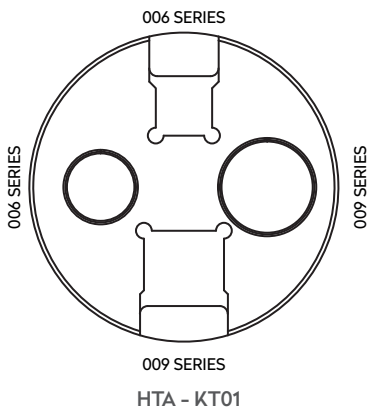
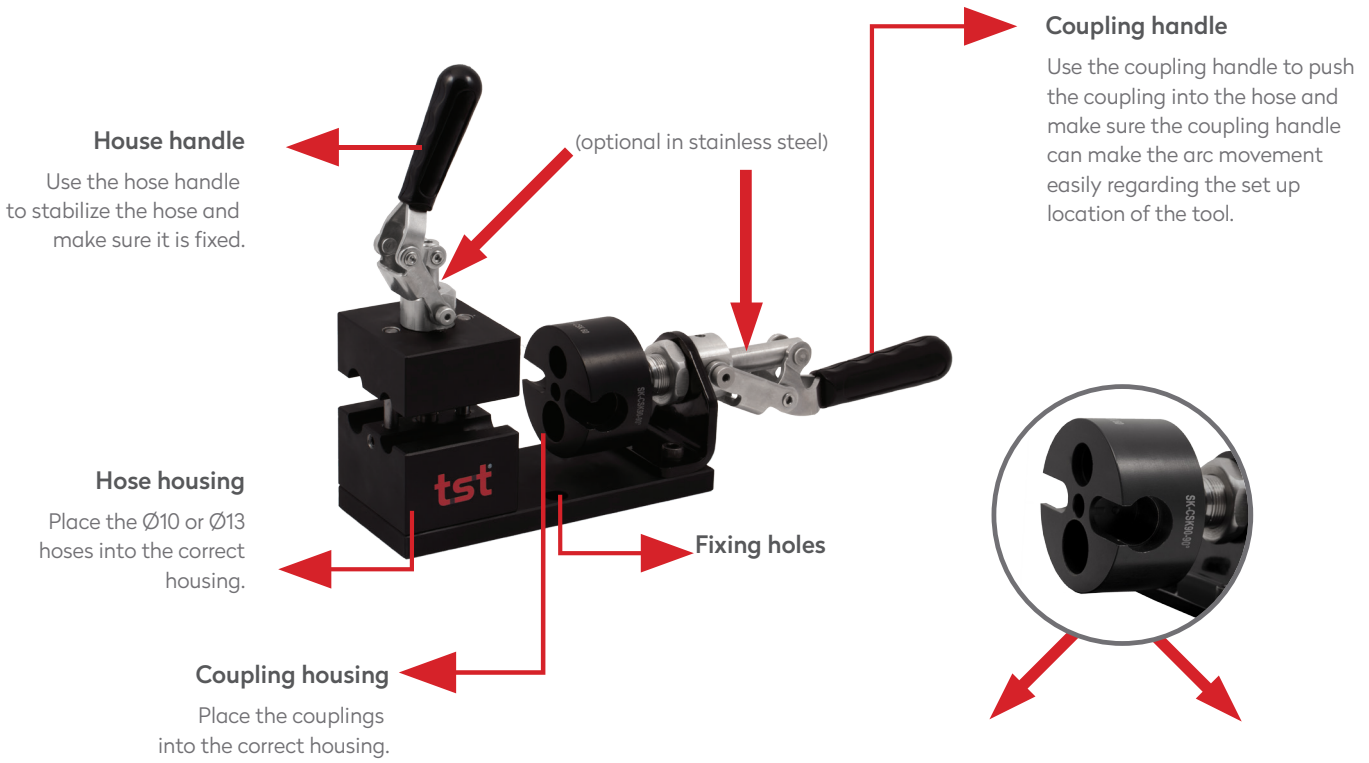

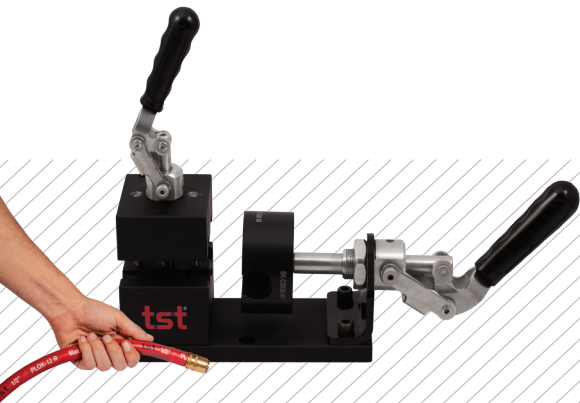

PUSH TO LOCK - HOSE ASSEMBLY TOOL

SCHLAUCH-MONTAGEWERKZEUG

SERIE HTA 10-13

HOW IT WORKS

1

Insert the hose into the suitable groove in the hose housing and rotate the hose handle to clamp the hose down.

Suitable Ø10 hoses for the application are;
 PLOK10 - PDLOK10 - WHMLOK10 - WHMDLOK10
 and Ø12 hoses are; PLOK12 - PDLOK12 - WHMLOK12 - WHMDLOK12

2

Make sure the hose inlet is max 3 cm away from the housing in order to keep the hose inlet stable and ready for assembly.

The hose inlet can either be perfectly aligned with the housing or max 3 cm away from the housing for an easier assembly of couplings.

3

Place the coupling into the suitable coupling housing and make sure the accurate housing is installed on the tool. If not, please replace the housing with the other housing which you will find in the box.

The housing kit can either be for SK-CSK90, SK-CSK60-90, SK-CSK90-90, 100.08 or HK-HVK9-90, HK-HVK9,100.08-90 type of couplings.
 EHF type of adaptors are also suitable for usage.

4

Rotate the coupling handle in order to have the coupling touch the hose inlet.

Once you are sure both are aligned, please push the flexible hose tail all the way into the hose.

